

M O T O R C O M P A N Y

MA7200 *PLUS* AC Inverter

Installation Manual

200 to 240V 1Ø & 3Ø 1 - 3 HP
3Ø 5 - 40 HP

380 to 480V 3Ø 1 - 75 HP

500 to 600V 3Ø 1 - 10 HP



Table of Contents

	<u>Page</u>
1.0 MA7200 PLUS Inspection, Handling and Installation.....	
1.1. Inspection Procedure Upon Receiving.....	
1.2 Installation.....	
1.3 Removing the Front Cover and Digital Operator.....	
2.0 General Wiring Diagrams.....	
3.0 Power Section, Terminal Layout, Wiring and Ratings.....	
3.1 Power Terminals.....	
3.2 Power Input / Output Block Diagrams.....	
3.3 Wiring Precautions.....	
3.4 Power Input Wire Size, NFB and MCB Part Numbers.....	
3.5 Notes for Circuit Protection and Environmental Ratings.....	
3.6 Electrical Ratings for Constant Torque and Quadratic Torque.....	
3.7 Inverter Heat Loss.....	
4.0 Control Terminals Designations and Wiring.....	
4.1 Control Terminals Layout.....	
4.2 Control Circuit Wiring.....	
5.0 Peripheral Power Devices Overview.....	
5.1 AC Input Reactor.....	
5.2 Input Fuse Types and Ratings.....	
5.3 Noise Filters.....	
5.4 Braking Resistors and Braking Units.....	
6.0 Peripheral Control Devices.....	
6.1 LCD Operator with Extension Cable.....	
6.2 Analog Operator.....	
6.3 PROFIBUS Communication Card.....	
7.0 MA7200 PLUS Specifications.....	
7.1 Basic Specifications.....	
7.2 General Specifications.....	
7.3 MA7200 PLUS Dimensions and Weights.....	
8.0 Parameter Groups, The Digital Operator, Menus and Keypad Navigation.....	
8.1 Parameter Groups.....	
8.2 Digital Operator Layout and Description.....	
8.3 Digital Operator Key Functions.....	
8.4 Run / Stop Status Indicators.....	
8.5 Display Menu for DRIVE and PRGM Modes.....	
8.6 Some Examples of keypad navigation.....	

Cont.

- 9.0 Parameter Summary and Explanation.....**
- 9.1 Parameter Summary Tables.....**
- Table 9.1.1 An- □□ Frequency Command (Multi-speed operation).....
- Table 9.1.2 Bn- □□ Parameter Groups that can be Changed During Running.....
- Table 9.1.3 Cn- □□ Control Parameters.....
- Table 9.1.4 Sn- □□ System Parameters.....
- Table 9.1.4 P□- □□ Application Parameters.....
- Table 9.1.5 Un- □□ Monitoring Parameters.....

- 9.2 Parameter Detail.....**
- 9.2.1 Parameters Bn- (Parameter Groups that can be Changed During Running).....
- 9.2.2 Parameters Cn- (Control Parameters).....
- 9.2.3 Parameters Sn- (System Parameters).....
- 9.2.4 Parameters P□ (Application Parameters).....
- 9.2.5 Parameters Un- (Monitoring Parameters).....

- 10.0 Error Messages and Troubleshooting.....**
- 10.1 General.....**
- 10.1.1 Fault.....
- 10.1.2 Warnings and Self- Diagnosis.....

- Appendix A - Auto-tuning Procedure / Sensorless Vector Control.....**
- Appendix B - Spare Parts.....**
- Appendix C - Inverter Parameter Setting List.....**

- APP-1 PID Application Note.....**
- APP-2 Fan and Pump Application Note.....**

- Warranty.....**



1.0 MA7200 PLUS Inspection, Handling and Installation

1.1 Inspection Procedure upon Receiving

Before delivery, Every MA7200 PLUS inverter has been functionally tested and adjusted. After receiving the inverter, use the following procedure to ensure that the proper equipment has been received and is not damaged.

- Verify that the Model No. of the inverter you've received is the same as that listed on your purchase order. (Refer to the Nameplate)
- Observe the condition of the shipping container and report any damage immediately to the commercial carrier that delivered the equipment.

■ Inverter Nameplate:

Model: MA7200-2002-N1	2.7KVA	●	Inverter Model
AC Input: 1PH/3PH 200-240V 50/60Hz			
AC Output: 6.4A at 150% for 60 Sec. (CT)		●	Output Power Specifications
7.6A at 110% for 60 Sec. (VT)			
Reference Installation Manual			
TECO-Westinghouse Motor Company		 US LISTED 18KJ Power Conversion Equipment E177007	 Factory ID: X

- Inverter Model Numbering:

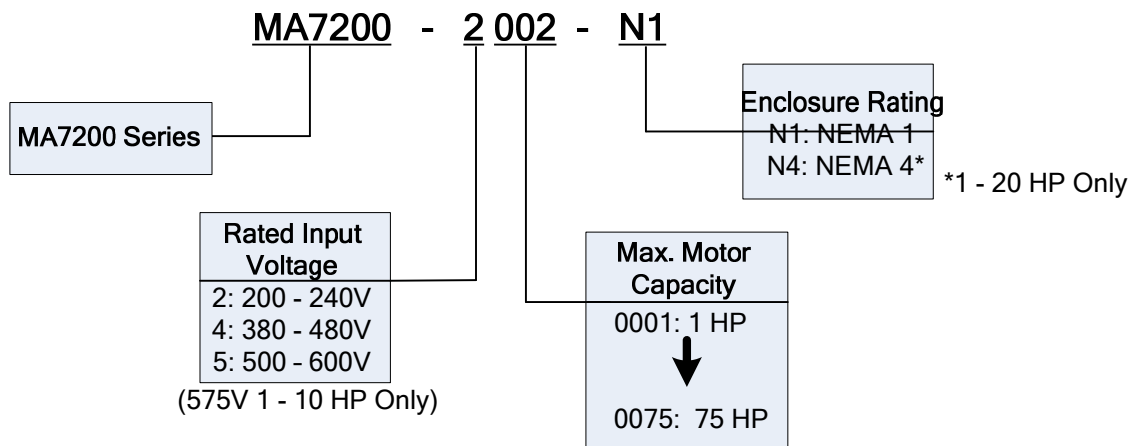

NOTES-

1.2 Installation

When installing the inverter, ensure that there is adequate space around the unit to allow normal heat dissipation as per the following Fig. 1.2.1

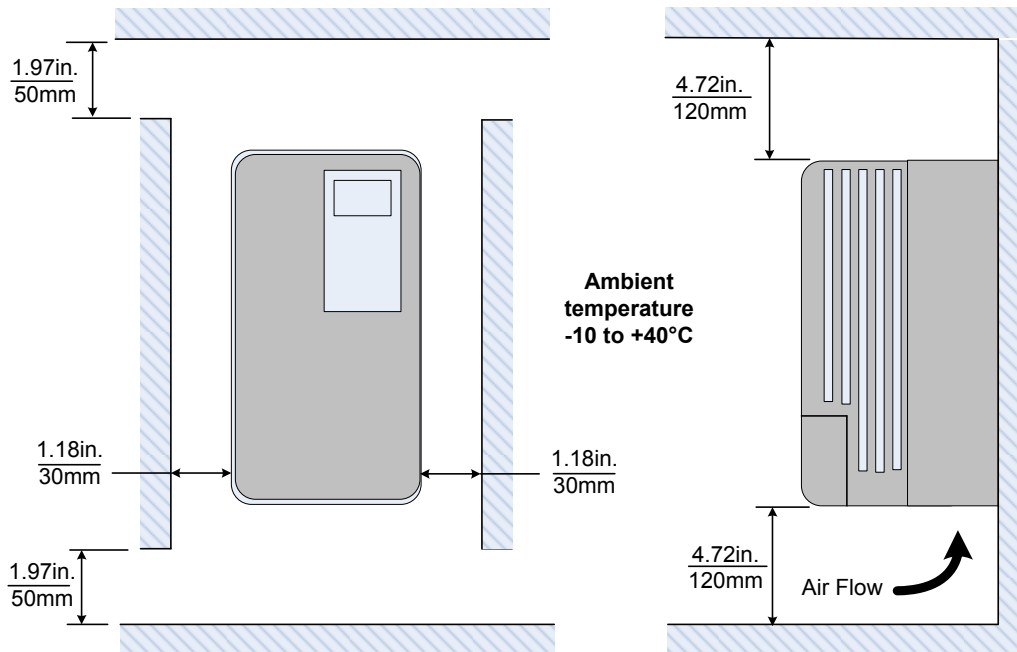

Fig. 1.2.1 MA7200 PLUS Wall Mount Clearance

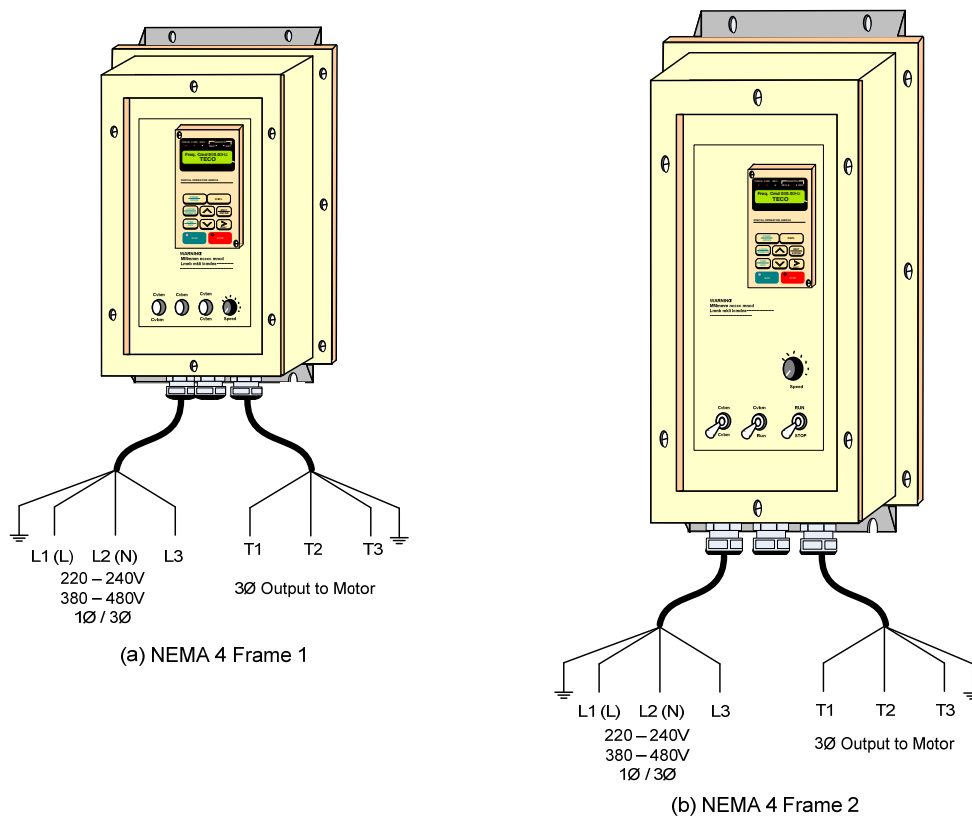

Fig. 1.2.2 MA7200 PLUS NEMA 4 Installation *Cont.*

! CAUTION

Location of equipment is important to achieve proper performance and normal operating life. The MA7200 PLUS inverter should be installed in area meeting the following conditions.

- Ambient temperature: +14 to 104°F, (-10 to 40°C).
- The location is protected from rain, moisture and direct sunlight.
- The location is free from harmful mists, gases, liquids, airborne dusts and metallic particles.
- The location is free from vibration and electromagnetic noise. (i.e. welding machines, power units, etc...)
- When mounting multiple units in a common enclosure, install a cooling fan or some other means to maintain the enclosure temperature below 104°F (+40°C).

1.3 Removing the Front Cover and Digital Operator

! CAUTION

Before making any wiring connections to the MA7200 PLUS, the front cover needs to be removed.

- For models 230V, 1-25HP; 460V, 1-30HP and 575V 1-10HP: (Plastic cover) -The Digital Operator must be disassembled first before disassembling the front cover. After completing the wiring connection, assemble front cover first then the Digital Operator.
- For models 230V, 30HP&40HP and 460V, 40- 75HP: (Metal cover)- The front cover can be removed for wiring connection without disassembling the Digital Operator. Reinstall the front cover after completing the wiring.

The procedure for disassembly / assembly for the MA7200 PLUS inverter will be dependent on the model as follows:

(A) 230V: 1-2HP and 460V: 1-2HP

- MA7200-2001-N1
 - MA7200-2002-N1
 - MA7200-4001-N1
 - MA7200-4002-N1
- Removing the front cover and Digital Operator:
Remove the two screws a and b on the front cover and remove. Next, remove the screws c and d on the Digital Operator and carefully pull upward enough to expose the connecting cable. Disconnect the RS-232 cable on the backside of the Digital Operator and remove the Digital Operator.
- Attaching the front cover and Digital Operator:
Carefully connect the RS-232 cable connector to the back of the Digital Operator, place it on the inverter housing and secure with screws c and d. Insert the tabs of the upper part of front cover into the groove of the inverter housing and secure with screws a and b.

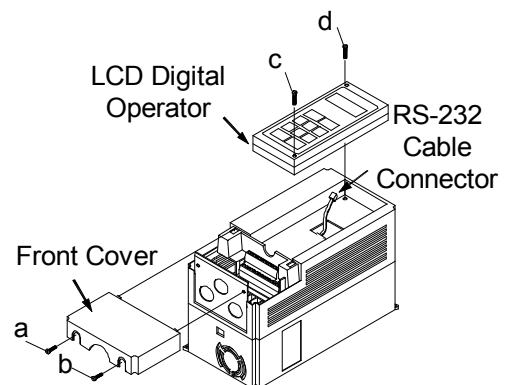

Cont.

(B) 230V: 3-10HP, 460V: 3-10HP and 575V: 1 -10 HP

- MA7200-2003-N1
- MA7200-2005-N1
- MA7200-2007-N1
- MA7200-2010-N1

- MA7200-4003-N1
- MA7200-4005-N1
- MA7200-4007-N1
- MA7200-4010-N1

- MA7200-5001-N1
- MA7200-5002-N1
- MA7200-5003-N1
- MA7200-5005-N1

- MA7200-5007-N1
- MA7200-5010-N1

■ Removing the digital operator

Remove screws a and b. Press the lever on the side of the Digital Operator in the direction of arrow 1 to unlock the Digital Operator. Carefully disconnect the RS-232 cable connector on the back side of the LCD digital operator and lift the Digital Operator in the direction of arrow 2 to remove.

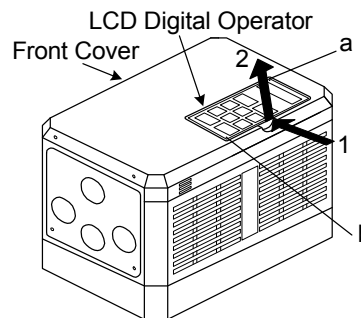

■ Removing the front cover

Press the left and right sides of the front cover in the directions of arrow 1 and lift the bottom of the cover in the direction of arrow 2 to remove.

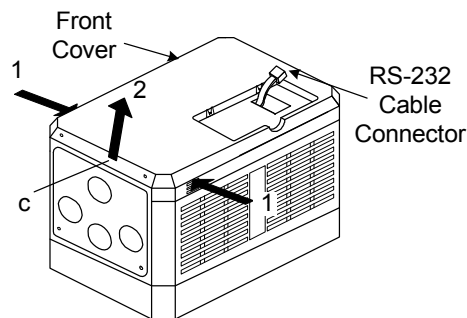

■ Mounting the front cover and Digital Operator

Insert the tab of the upper part of front cover into the groove of the inverter housing and press the lower part of the front cover onto the inverter until it snaps into place.

Connect the RS-232 cable connector to the back side of the Digital Operator and hook the one side of the Digital Operator on the front cover in the direction of arrow 1.

Press the digital operator in the direction of arrow 2 until it snaps into place and then secure with c and d.

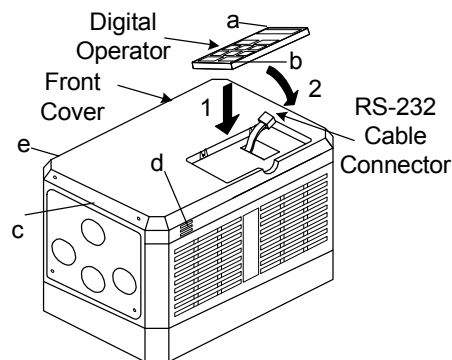

Cont.

230V: 15,20HP and 460V: 15,20HP Series

- MA7200-2015-N1
- MA7200-4015-N1
- MA7200-2020-N1
- MA7200-4020-N1

■ Removing the Digital Operator:

Remove screws a and b and carefully lift up to expose the connecting cable. Disconnect the RS-232 cable connector on the back side of the Digital Operator and then remove the Digital Operator.

■ Removing the front cover:

Loosen the two screws c and d of the front cover c and d and lift the bottom of the front cover to remove.

■ Mounting the front cover and Digital Operator:

Insert the tab of the upper part of front cover into the groove of the inverter housing and secure with screws c and d.

Connect the RS-232 cable connector on the back of the Digital Operator. Place the Digital Operator into the inverter housing and secure with screws a and b.

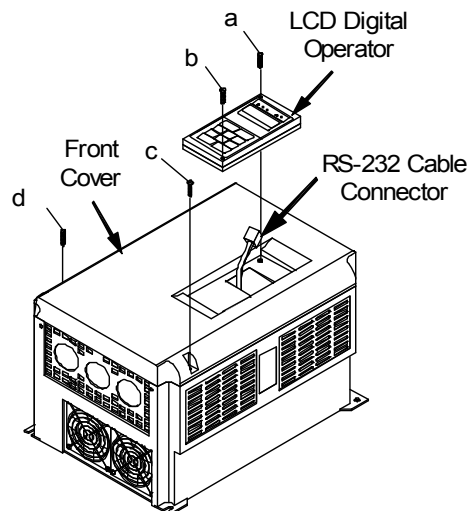

(C) 230V: 30- 40HP and 460V: 40- 75HP Series

■ Removing the front cover:

Loosen the two screws a and b of the front cover. Then loosen the two screws c and d and lift the front cover upwards. (Do not removing the digital operator.)

■ Mounting the front cover:

Place the front cover on the inverter housing and then secure with screws a, b, c and d.

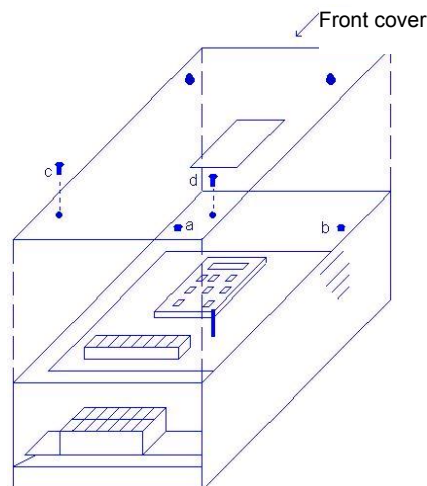

2.0 General Wiring Diagrams

The general wiring diagram of the MA7200 PLUS is shown in Fig's. 2.1.1 and 2.1.2. There are three types of control boards, the first is shown in Fig. 2.1.1 and the other two in Fig. 2.1.2 along with the terminal arrangement.

Cont.

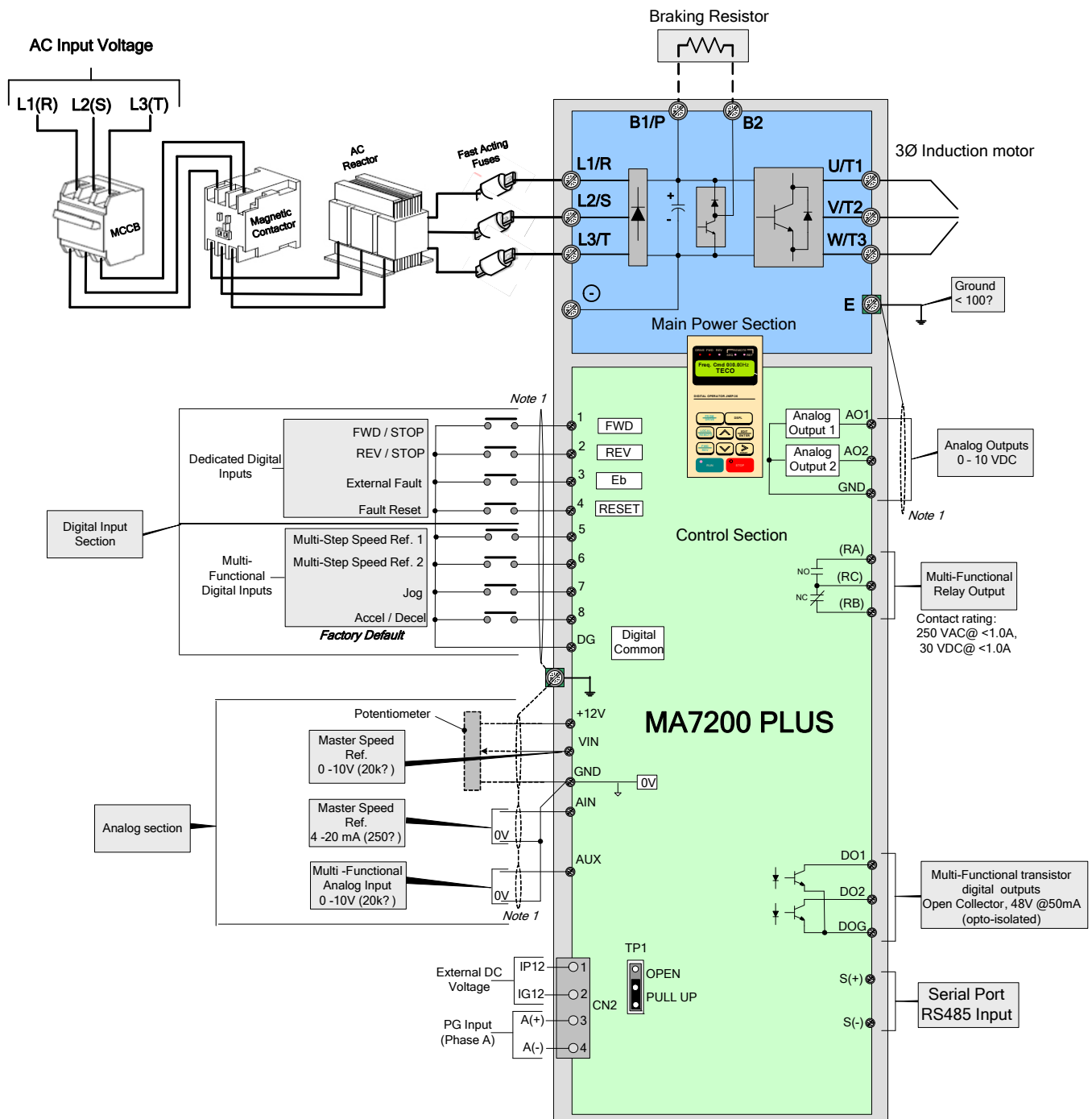

Terminal Layout (Control Board code No.: 4H300D6730027)

DG	1	3	5	7	VIN	AIN	AUX	DO1	DO2	DOG	S(-)
E	2	4	6	8	+12	GND	GND	AO1	AO2	S(-)	E
								RA	RB	RC	

NOTES:

- 1 - Use shielded wiring for digital inputs and analog outputs and shielded twisted pair for analog inputs
- 2 - Terminals A(+) and A(-) can be used as a pulse frequency input command, 50Hz - 32kHz, with an H of 3-12V. (Input resistance 27K). In this case jumper TP1 must be set in the OPEN position. (CN2 connector wire code: 4H339D0250001)

Fig. 2.1.1 General Wiring Diagram

NEMA 1 - 230V: 1 - 2HP and 460V: 1 - 2HP (NEMA4 is the same)
 (Models: MA7200-2001/2-N1 and MA7200-4001/2-N1)

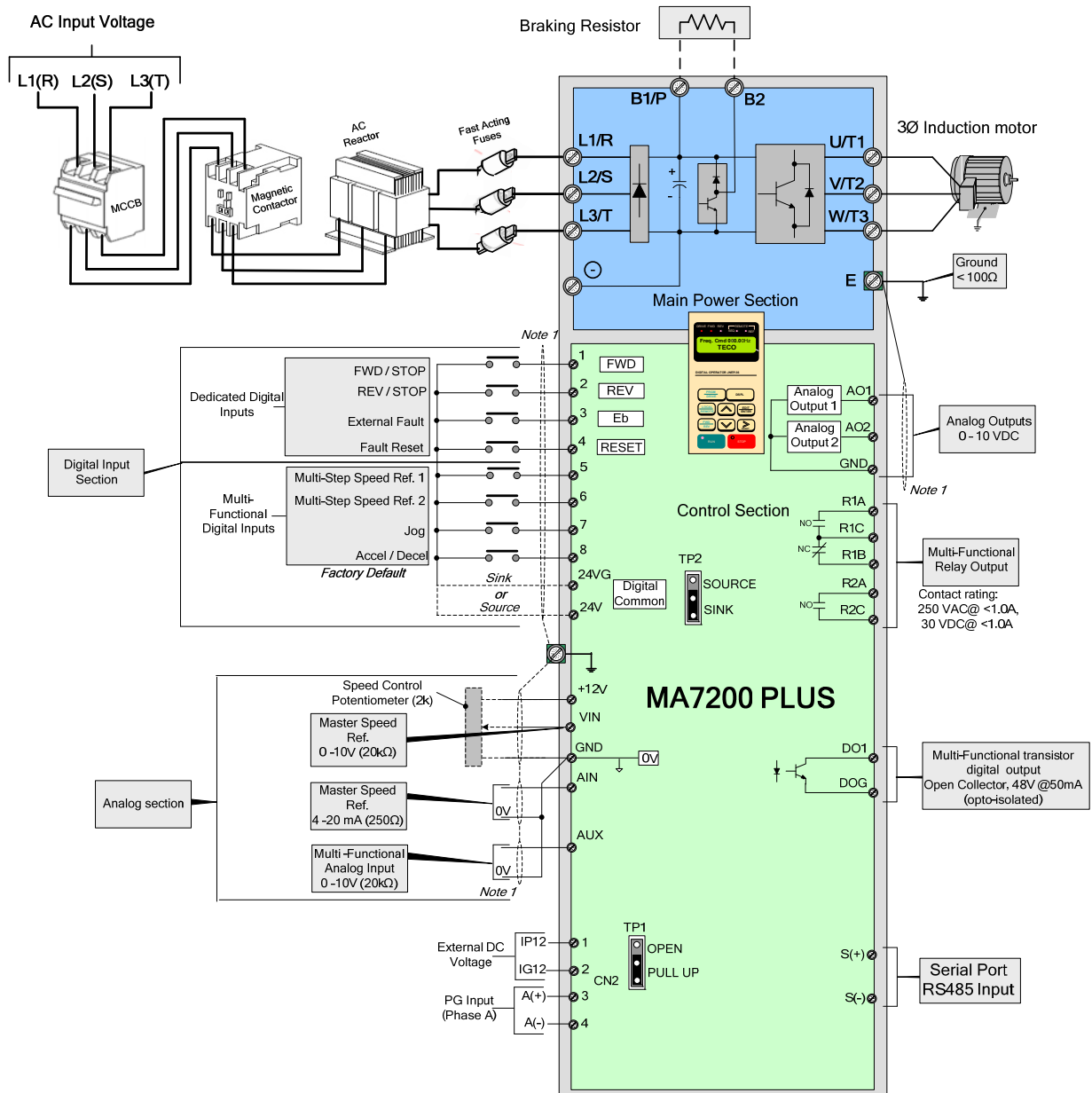

Terminal Layout (Control Board code No.: 4H300D6740022 230V: 3 - 25HP and 460V: 3 - 30HP)
 (Control Board code No.: 4H300D6750028 230V: 30 - 40HP and 460V: 30 - 75HP)
 (Control Board code No.: 4LA41X258S01 575V: 1 - 10HP)

24VG	1	3	5	7	24V	VIN	AIN	AUX	DO1	DOG	IP12	A(+)	A(-)						
E	2	4	6	8	+12V	-12V	GND	AO1	AO2	E	IG12	S(+)	S(-)	R2A	R2C	R1A	R1B	R1C	

- NOTES:**
- 1 - Use shielded wiring for digital inputs and analog outputs and shielded twisted pair for analog inputs
 - 2 - Digital inputs 1 - 8 can be set for SINK (0V Common) or Source (+24V common by setting the jumper TP2).
 - 3 - Terminals A(+) and A(-) can be used as a pulse frequency input command, 50Hz - 32kHz, with an H of 3-12V. (Input resistance 27K). In this case jumper TP1 must be set in the OPEN position.

Fig. 2.1.2 General Wiring Diagram

NEMA 1 - 230V: 3 - 40HP, 460V: 3- 75HP (NEMA4 up to 20HP) and 575: 1-10HP
 (230V Models: MA7200-2003 thru MA7200-2040-N1), (460 Models: MA7200-4003-N1 thru MA7200-4075-N1)
 and (575V Models: MA7200-5001-N1 thru MA7200-5010-N1)

5.0 Power Section Terminal Layout, Wiring and Ratings

5.1 Power Terminals

The following Fig. 3.1.1 and Table 3.1.1 shows the power terminal layout and description for the complete horsepower range.

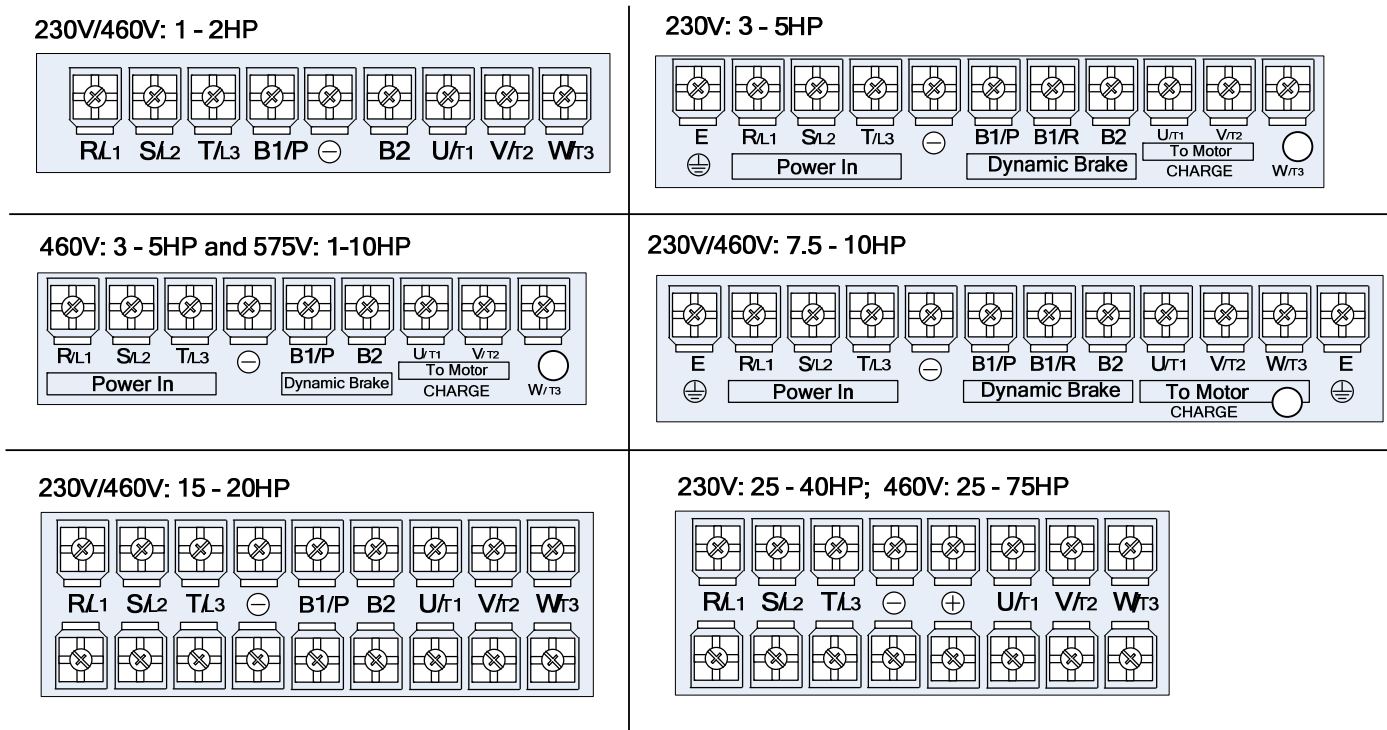



Fig. 3.1.1 Power Terminal Layout

Table 3.1.1 Power Terminal Designations

Terminal	230V: 1 - 20HP; 460V: 1 - 20HP 575V: 1 - 10 HP	230V: 25 - 40HP; 460V: 25 - 75HP
R/L1	Input Power Supply (For single phase use terminals R/L1 and S/L2)	
S/L2		
T/L3		
B1/P	B1/P, B2: External Braking Resistor B1/P, ⊖: DC Power Supply Input	⊕-⊖: DC Power Supply or Braking Unit
B2		
⊖		
⊕		
B1/R		
U/T1	Inverter Output to 3Ø Induction Motor	
V/T2		
W/T3		
E	Ground (3rd type grounding)	

3.3 Wiring Precautions

 Danger	<ul style="list-style-type: none"> Do Not remove any protective covers or attempt any wiring while input power is applied. Connect all wiring before applying input power. When making wiring changes after power up, remove input power and wait a minimum of five minutes after power has been turned off before starting. Also confirm that the charge lamp is off and that DC voltage between terminals B1/P or (+) and (-) does not exceed 25V, otherwise electric shock may result. Only authorized personnel should work on the equipment. (Take off metal jewelry such as watches and rings and use insulated tools.), otherwise electric shock or injury may result.
---	---

(A) Power input terminals

- The Input power supply voltage can be connected in any phase sequence to power input terminals R/L1, S/L2, or T/L3 on the terminal block.
- DO NOT connect the AC input power source to the output terminals U/T1, V/T2 and. W/T3.
- Connect the output terminals U/T1, V/T2, W/T3 to motor lead wires U/T1, V/T2, and W/T3, respectively.
- Check that the motor rotates forward with the forward run source. If it does not, swap any 2 of the output cables to change motor direction.
- DO NOT connect phase correcting capacitors or LC/RC noise filter to the output circuit.

(B) Grounding

- Connect the ground terminal (E) to ground having a resistance of less than 100Ω.
- Do not share the ground wire with other devices, such as welding machines or power tools.
- Always use a ground wire that complies with the local codes and standards for electrical equipment and minimize the length of ground wire.
- When using more than one inverter, be careful not to loop the ground wire, as shown below in Fig. 3.4.

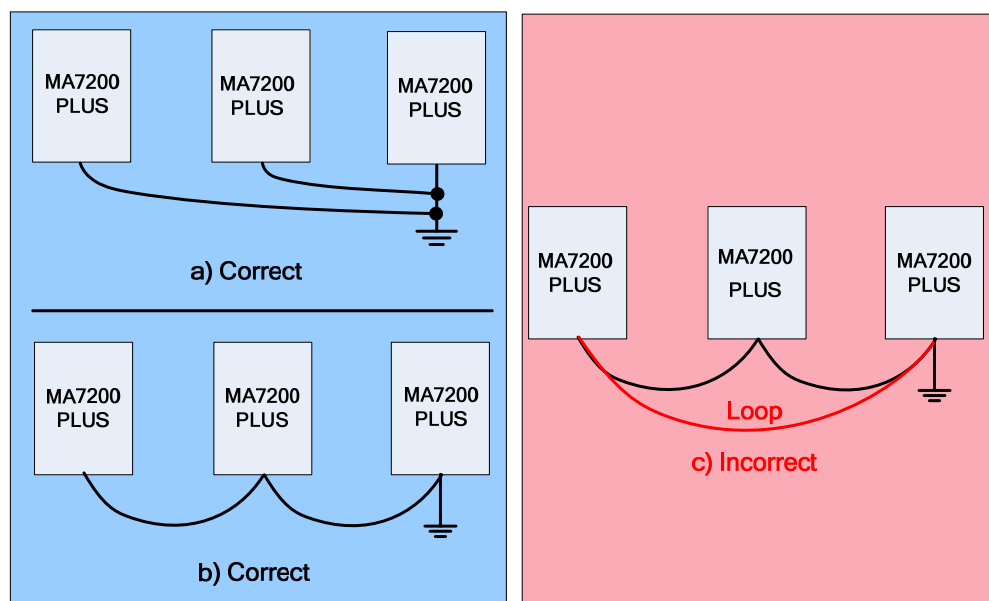

Fig. 3.3.1 Inverter Grounding

Table 3.4.1a NEMA 1 Wire Size, NFB & MCB Part Numbers vs. HP

MA7200 PLUS HP				Wire Size AWG / (mm ²) ^{*4}		Terminal Size MC / G	Tightening Torque In. / lbs MC / G	NFB ^{*3}	MCB ^{*3}
Input Power	HP ^{*1}	Rated KVA	Rated Current (A)	Main Circuit ^{*2}	Ground Connecting Wire E (G)				
230V 1 Ø / 3 Ø	1	2	4.8	#14 - #10 / 2 - 5.5	#14 - #10 / 2 - 5.5	M4/M4	10/10	TO-50EC(15A)	CN-11
	2	2.7	6.4		#12 - #10 / 3.5 - 5.5			TO-50EC(20A)	CN-11
	3	4	9.6	#12 - #10 / 3.5 - 5.5				TO-50EC(20A)	CN-11
230V 3 Ø	5	7.5	17.5	#10 / 5.5	#10 / 5.5	M6/M6	30/35	TO-50EC(30A)	CN-16
	7.5	10.1	24	#8 / 8	5.5 - 8			TO-100S(50A)	CN-18
	10	13.7	32					TO-100S(60A)	CN-25
	15	20.6	48	#6 / 14	#8 / 8			TO-100S(100A)	CN-50
	20	27.4	64	#4 / 22	#6 / 14	M8/M10	78/156	TO-100S(100A)	CN-65
	25	34	80					TO-225S(150A)	CN-80
	30	41	96	#1 / 38	#4 / 22	TO-225S(175A)	CN-100		
	40	54	130	#00 / 60		TO-225S(175A)	CN-125		
460V 3 Ø	1	2.2	2.6	#14 - #10 / 2 - 5.5	#14 - #10 / 2 - 5.5	M4/M4	10/10	TO-50EC(15A)	CN-11
	2	3.4	4		#12 - #10 / 3.5 - 5.5			TO-50EC(15A)	CN-11
	3	4.1	4.8					TO-50EC(15A)	CN-11
	5	7.5	8.7					TO-50EC(15A)	CN-18
	7.5	10.3	12	#12 - #10 / 3.5 - 5.5	#12 - #10 / 3.5 - 5.5	M6/M6	15/35	TO-50EC(20A)	CN-18
	10	12.3	15	#10 / 5.5	#10 / 5.5			TO-50EC(30A)	CN-25
	15	20.6	24	#8 / 8	#8 / 8			TO-50EC(30A)	CN-25
	20	27.4	32			TO-100S(50A)	CN-35		
	25	34	40	#6 / 14	#6 / 14	M8/M10	78/156	TO-100S(75A)	CN-50
	30	41	48					TO-100S(100A)	CN-50
	40	54	64	#4 / 22		TO-100S(100A)	CN-65		
	50	68	80	#1 / 38	#6 / 14	TO-125S(125A)	CN-80		
	60	82	96			TO-225S(175A)	CN-100		
75	110	128	#00 / 60	#4 / 22	TO-225S(175A)	CN-125			
575V 3 Ø	1	1.7	1.7	#14 - #10 / 2 - 5.5	#14 - #10 / 2 - 5.5	M4/M4	10/10	TO-50EC(15A)	CN-11
	2	3.0	3.0		#12 - #10 / 3.5 - 5.5			TO-50EC(15A)	CN-11
	3	4.2	4.2					TO-50EC(15A)	CN-11
	5	6.6	6.6	#12 - #10 / 3.5 - 5.5	#12 - #10 / 3.5 - 5.5	TO-50EC(15A)	CN-18		
	7.5	9.9	9.9			TO-50EC(15A)	CN-18		
	10	12.2	12.2			TO-50EC(20A)	CN-18		

*1 - Constant torque load.

*2 - The main circuit includes terminals (R/L1, S/L2, T/L3, U/T1, V/T2, W/T3, B1/P, B2/R, B2, Ø).

If the length of the input power cable results in a voltage drop > 2%, a wire size with a larger diameter may be necessary. To calculate this reduction, apply the following formula:

$$\text{Phase-to-phase voltage drop (V)} = \sqrt{3} \times \text{resistance of wire } (\Omega/\text{km}) \times \text{length of line (m)} \times \text{current} \times 10^{-3}$$

*3 - In Table 3.4.1a, the specified NFB and MCB are TECO Part No's. Similar products with equivalent ratings from other sources may be used. To decrease noise interference, add a R-C surge suppressor having a rating of (R:10Ω / 5W, C: 0.1uF / 1000VDC) at the terminals of the coils of the electromagnetic contactor.

*4 - Use 140 / 167°F (60 / 75°C) copper wire only).

Table 3.4.1b NEMA 4 Wire Size, NFB & MCB Part Numbers vs. HP

MA7200 PLUS HP				Wire Size AWG / (mm ²) *4		Terminal Size MC / G	Tightening Torque In. / lbs MC / G	NFB *3	MCB *3
Input Power	HP *1	Rated KVA	Rated Current (A)	Main Circuit *2	Ground Connecting Wire E (G)				
230V 1 Ø / 3 Ø	1	2	4.8	#14 - #10 / 2 - 5.5	#14 - #10 / 2 - 5.5	M4/M4	10/10	TO-50EC(15A)	CN-11
	2	2.7	6.4		#12 - #10 / 3.5 - 5.5			TO-50EC(20A)	CN-11
	3	4	9.6	#12 - #10 / 3.5 - 5.5	#10 / 5.5			TO-50EC(20A)	CN-11
230V 3 Ø	5	7.5	17.5	#8 / 8	#10 / 5.5	M6/M6	35/35	TO-50EC(30A)	CN-16
	7.5	10.1	24		#10 - #8 / 5.5 - 8			TO-100S(50A)	CN-18
	10	13.7	32	#4 / 22	#8 / 8			TO-100S(60A)	CN-25
	15	20.6	48					TO-100S(100A)	CN-50
	20	27.4	64					#2 / 35	TO-100S(100A)
460V 3 Ø	1	2.2	2.6	#14 - #10 / 2 - 5.5	#14 - #10 / 2 - 5.5	M4/M4	10/10	TO-50EC(15A)	CN-11
	2	3.4	4		#12 - #10 / 3.5 - 5.5			TO-50EC(15A)	CN-11
	3	4.1	4.8		#12 - #10 / 3.5 - 5.5			TO-50EC(15A)	CN-11
	5	7.5	8.7	#12 - #10 / 3.5 - 5.5	TO-50EC(15A)			CN-18	
	7.5	10.3	12	#10 / 5.5	#10 / 5.5	M6/M6	35/35	TO-50EC(20A)	CN-18
	10	12.3	15	#12 - #10 / 3.5 - 5.5	#12 - #10 / 3.5 - 5.5			TO-50EC(30A)	CN-25
	15	20.6	24	#10 / 5.5	#10 / 5.5			TO-50EC(30A)	CN-25
	20	27.4	32	#12 - #10 / 3.5 - 5.5	#12 - #10 / 3.5 - 5.5			TO-100S(50A)	CN-35

*1 - Constant torque load.

*2 - The main circuit includes terminals (R/L1, S/L2, T/L3, U/T1, V/T2, W/T3, B1/P, B2/R, B2 and Ø).

If the length of the input power cable results in a voltage drop > 2%, a wire size with a larger diameter may be necessary. To calculate this reduction, apply the following formula:

$$\text{Phase-to-phase voltage drop (V)} = \sqrt{3} \times \text{resistance of wire } (\Omega/\text{km}) \times \text{length of line (m)} \times \text{current} \times 10^{-3}$$

*3 - In Table 3.4.1b, the specified NFB and MCB are TECO Part No's. Similar products with equivalent ratings from other sources may be used. To decrease noise interference, add a R-C surge suppressor having a rating of (R:10Ω / 5W, C: 0.1uF / 1000VDC) at the terminals of the coils of the electromagnetic contactor.

*4 - Use 140 / 167°F (60 / 75°C) copper wire only).

3.6 Notes for Circuit Protection and Environmental Ratings

- Circuit Protection**

The MA7200 PLUS is suitable for use in a circuit capable of delivering *not* more than the RMS value symmetrical amperes and V maximum shown in the following table 3.5.1.

Table 3.5.1 Circuit Protection Ratings

Device Rating		Short Circuit Rating (A)	Maximum Voltage (V)
Voltage	HP		
230V	1.5 - 50	5,000	240V
	51 - 100	10,000	
460V	1.5 - 50	5,000	480V
	51 - 200	10,000	

- Environmental Ratings**

The MA7200 is intended for use in pollution degree 2 environments.

3.8 Electrical Ratings for Constant Torque and Quadratic Torque

The following table 3.6.1a shows the electrical ratings for constant and quadratic torque.

Table 3.6.1a Electrical Ratings for Constant Torque and Quadratic Torque

MA7200 Model PLUS	Constant Torque (150%, 1minute)			Quadratic Torque (110%, 1minute)		
	Max. Appl. Motor Output HP (kW)	Rated Output Current (A)	Max. Switching Frequency (kHz)	Max. Appl. Motor Output HP (kW)	Rated Output Current (A)	Max. Switching Frequency (kHz)
MA7200-2001-N1	1 (0.75)	4.8 A	15	1 (0.75)	5.6 A	10
MA7200-2002-N1	2 (1.5)	6.4 A	15	2 (1.5)	7.6 A	5
MA7200-2003-N1	3 (2.2)	9.6 A	15	3 (2.2)	9.8 A	15
MA7200-2005-N1	5.4 (4)	17.5 A	15	7.5 (5.5)	22.7 A	5
MA7200-2007-N1	7.5 (5.5)	24 A	15	10 (7.5)	32 A	10
MA7200-2010-N1	10 (7.5)	32 A	15	10 (7.5)	32 A	15
MA7200-2015-N1	15 (11)	48 A	10	20 (15)	56.7 A	5
MA7200-2020-N1	20 (15)	64 A	10	25 (18.5)	70.9 A	5
MA7200-2025-N1	25 (18.5)	80 A	10	25 (18.5)	80 A	10
MA7200-2030-N1	30 (22)	96 A	10	40 (30)	108 A	5
MA7200-2040-N1	40 (30)	130 A	10	40 (30)	130 A	10
MA7200-4001-N1	1 (0.75)	2.6 A	15	1 (0.75)	2.9 A	5
MA7200-4002-N1	2 (1.5)	4 A	15	2 (1.5)	4.6 A	5
MA7200-4003-N1	3 (2.2)	4.8 A	15	3 (2.2)	4.9 A	15
MA7200-4005-N1	5.4 (4)	8.7 A	15	7.5 (5.5)	12.5 A	5
MA7200-4007-N1	7.5 (5.5)	12 A	15	10 (7.5)	15.4 A	10
MA7200-4010-N1	10 (7.5)	15 A	15	15 (11)	22.7 A	5
MA7200-4015-N1	15 (11)	24 A	10	20 (15)	30.3 A	5
MA7200-4020-N1	20 (15)	32 A	10	25 (18.5)	38 A	5
MA7200-4025-N1	25 (18.5)	40 A	10	30 (22)	44 A	5
MA7200-4030-N1	30 (22)	48 A	10	30 (22)	48 A	10
MA7200-4040-N1	40 (30)	64 A	10	50 (37)	71 A	5
MA7200-4050-N1	50 (37)	80 A	10	50 (37)	80 A	10
MA7200-4060-N1	60 (45)	96 A	10	75 (55)	108 A	5
MA7200-4075-N1	75 (55)	128 A	10	100 (75)	140 A	5
MA7200-5001-N1	1 (0.75)	1.7 A	10	*		
MA7200-5002-N1	2 (1.5)	3.0 A	10			
MA7200-5003-N1	3 (2.2)	4.2 A	10			
MA7200-5005-N1	5.4 (4)	6.6 A	10			
MA7200-5007-N1	7.5 (5.5)	9.9 A	10			
MA7200-5010-N1	10 (7.5)	12.2 A	10			

The above ratings are based on the following conditions shown in table 3.6b.

Cont.

Table 3.6.1b Conditions for Ratings in Table 3.6.1a

Item	Conditions	
	Constant Torque	Quadratic Torque
Output Overload	150% for 60s	110% for 60s
Operation Ambient Temperature	+14 - 104°F	+14 - 104°F
Allowable Voltage Fluctuation	-15% - +10%	-15% - +10%
Output Frequency	0.5Hz - 400Hz	0.5Hz - 400Hz
V/F curve	Dependent on parameter setting	Quadratic (or Cubic) Torque

3.9 Inverter Heat Loss

The following tables 3.7.1a, 3.7.1b and 3.7.1c show the heatsink, internal and total heat loss in watts for each inverters kVA and rated current.

Table 3.7.1a Inverter Heat Loss (200 – 230V)

Model MA7200-XXXX-N1		2001	2002	2003	2005	2007	2010	2015	2020	2025	2030	2040
Inverter Capacity kVA		2	2.7	4	7.5	10.1	13.7	20.6	27.4	34	41	54
Rated Current A		4.8	6.4	9.6	17.5	24	32	48	64	80	96	130
Heat Loss W	Heatsink	11	13	30	40	66	77	86	121	145	246	335
	Internal	65	77	185	248	409	474	529	742	889	1510	2059
	Total Heat Loss	76	90	215	288	475	551	615	863	1034	1756	2394

Table 3.7.1b Inverter Heat Loss (380 – 460V)

Model MA7200-XXXX-N1		4001	4002	4003	4005	4007	4010	4015	4020	4025	4030	4040	4050	4060	4075
Inverter Capacity kVA		2.2	3.4	4.1	7.5	10.3	12.3	20.6	27.4	34	41	54	68	82	110
Rated Current A		2.6	4	4.8	8.7	12	15	24	32	40	48	64	80	96	128
Heat Loss W	Heatsink	16	21	41	45	64	72	126	157	198	236	262	324	369	481
	Internal	99	129	249	278	393	442	772	965	1218	1449	1608	1993	2270	2957
	Total Heat Loss	115	150	290	323	457	514	898	1122	1416	1685	1870	2317	2639	3438

Table 3.7.1c Inverter Heat Loss (575V)

Model MA7200-XXXX-N1		5001	5002	5003	5005	5007	5010
Inverter Capacity kVA		1.7	3.0	4.2	6.6	9.9	12.2
Rated Current A		1.7	3.0	4.2	6.6	9.9	12.2
Heat Loss W	Heatsink	?	?	?	?	?	?
	Internal	?	?	?	?	?	?
	Total Heat Loss	?	?	?	?	?	?

4.0 Control Terminals Designations and Wiring

There are three different control boards that are used with the MA7200 PLUS. Each one is used with a specific horsepower range which is covered in the following explanations and in Fig. 2.1.1 and Fig. 2.1.2 in Section 2.

4.1 Control Terminals Layout

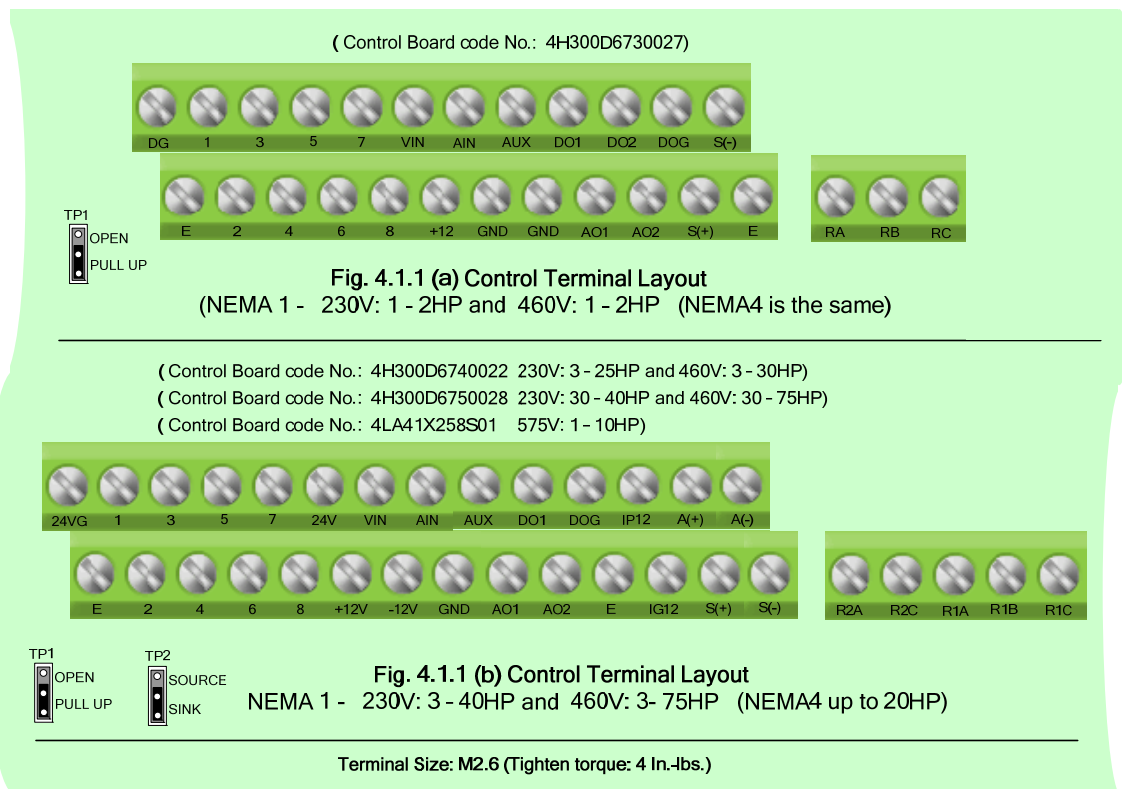

Fig. 4.1.1 MA7200 PLUS Control Board Terminal Layout

4.2 Control Circuit Wiring

- Separate the wiring for control circuit terminals RA-RB-RC (R1A-R2B-R2C) (Relay outputs) from wiring for terminals ① - ③, A01, A02, GND, DO1, DO2, DOG 24V (or +12V, -12V), VIN, AIN, AUX, GND, IP12, IG12, A (+), A (-), S (+) and S (-).
- Use shielded twisted-pair cables (#24 - #14 AWG / 0.5 -2 mm²) shown in Fig. 4.2.1 for control circuits to minimize noise problems. The maximum wiring distance should not exceed 165 Ft. (50 m).

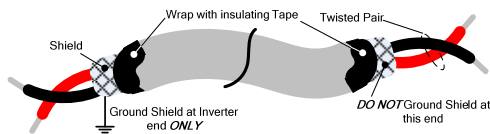

Fig. 4.2.1 Shielded Twisted-Pair

- When the digital multi-function output terminals (DO1, DO2) are connected to an external relay, a freewheeling diode should be connected across the relay coil to prevent an inductive voltage spike from damaging the output circuitry as shown in Fig. 4.2.2 below.

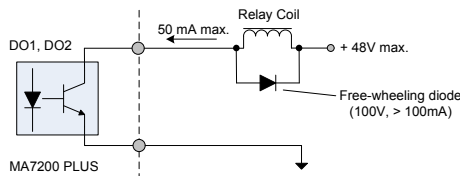

Fig. 4.2.2 Opto-Coupler Connected to an External Relay

Cont.

- (4) In Fig. 4.1.1b the control boards referenced have a jumper TP2 that can select the digital input to terminals ① - ③ to be set for SINK or SOURCE. The following Fig. 4.2.3 (a) – (d.) show examples for the various SINK / Source interfaces.

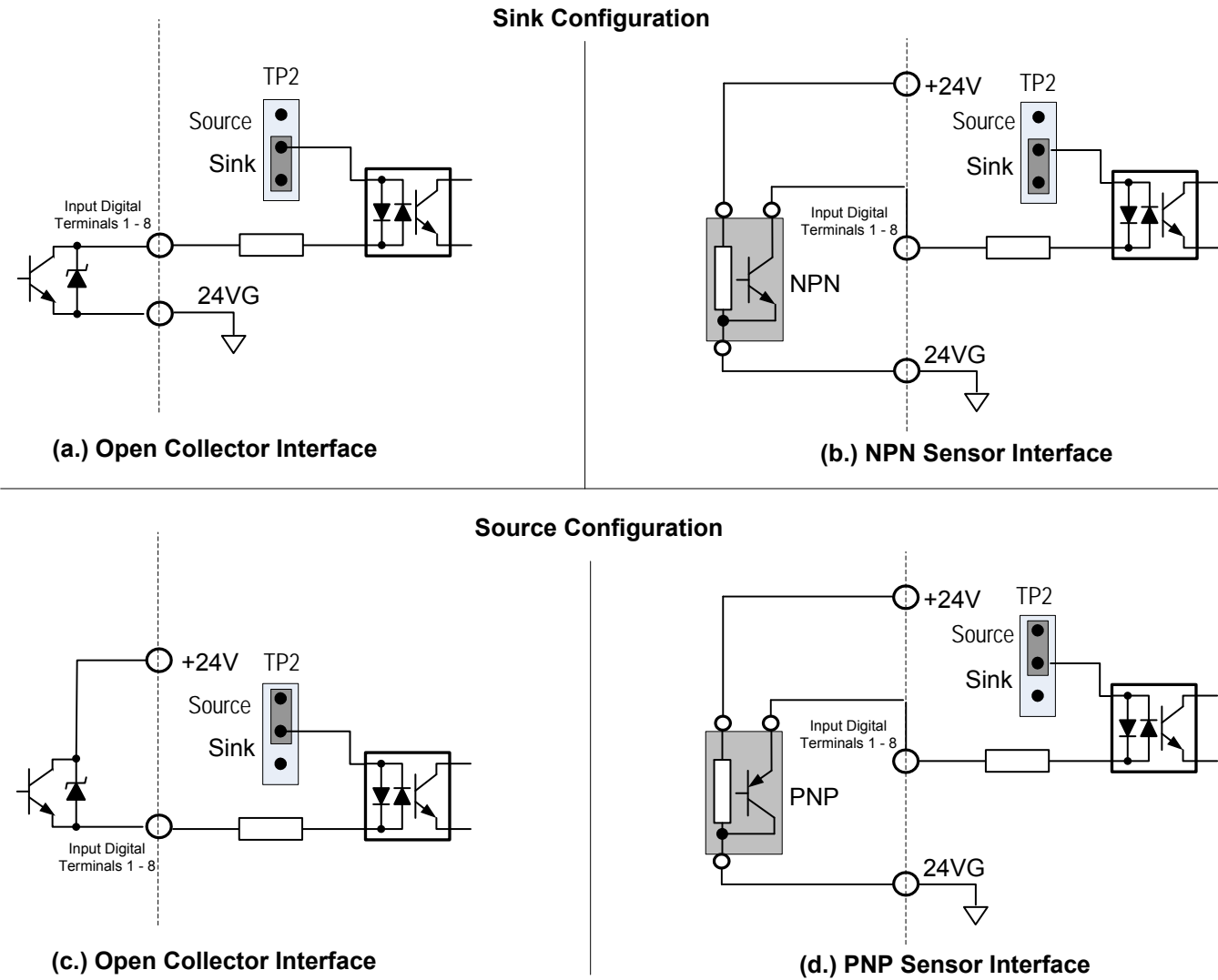

Fig. 4.2.3 Sink / Source Configurations

- (5) The MA7200 PLUS inverter has a built-in PG (Encoder) interface and no external PG feedback option card is required. An external DC source of +12V is required to provide power to the PG.

The following Fig.4.2.4 shows the wiring required for the PG interface.

Cont.

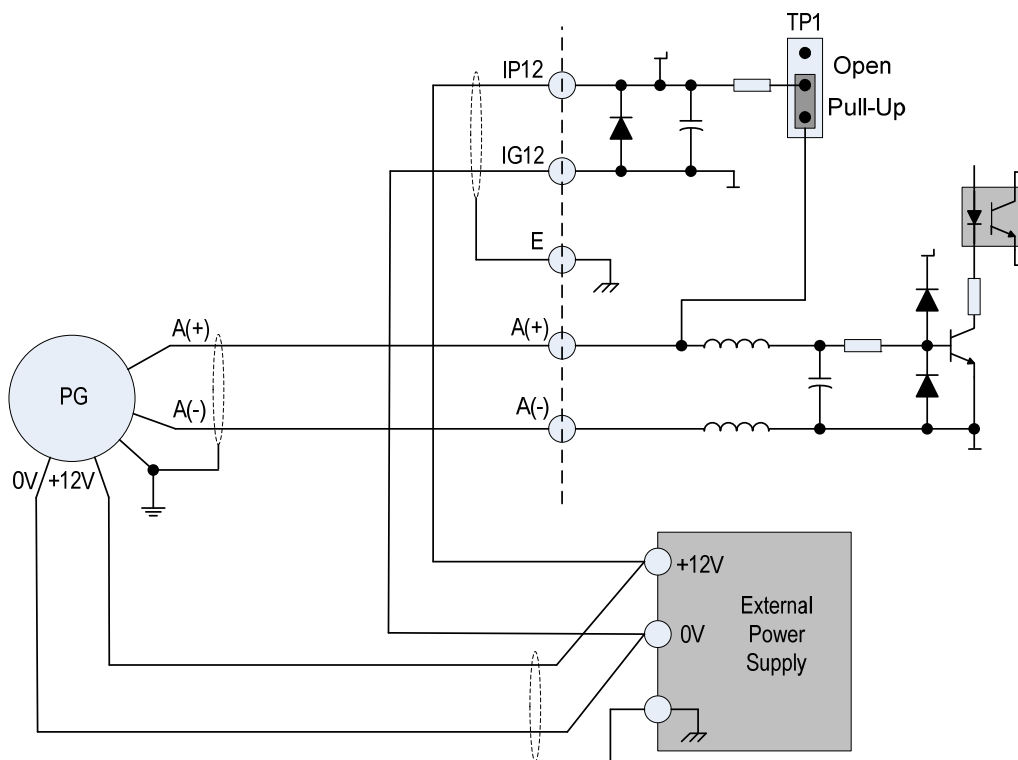

Fig. 4.2.4 PG Interface Wiring

Notes:

- 1 - Use twisted pair shielded cable and connect the shields to ground as shown.
- 2 - Terminal description:

Terminal	Description
A(+)	PG signal input terminal. Voltage level (H: 4 -12V, L: ≤1V). Max. frequency is < 32767 Hz
A(-)	
IP12	External power source input (+12V± 10%@ 40mA max.)
IG12	
+12V	External Power source (+12V± 10%, @ 0.5A min.)
0V	
E	Inverter ground.

- 3 - The A(+), A(-), IP12 and IG12 terminals are integrated in connector CN2 in compact version. (See Fig. 2.1.1). The code No. for the wiring is 4H339D0250001.
- 4 - The PG interface only supports an open-collector or complementary interface.
- 5 - The jumper TP1 is set to the PULL UP position for an open-collector interface (factory setting) and to the OPEN position for a complementary interface.
- 6 - The shielded twisted-pair cable used between the inverter and the PG should be less than 150 feet in length.
- 7 - Refer to the parameters in Section 9.0 for the settings used in the PG set-up.

Cont.

- (6) The MA7200 PLUS inverter terminals S(+) and S(-) provide a serial communication RS485 interface with a MODBUS protocol. PROFIBUS protocol for communication is possible with an optional PROFIBUS Communication Card (MA-SP).

A. MODBUS Communication Protocol

The following Fig. 4.2.5 shows the wiring interface for the MODBUS protocol.

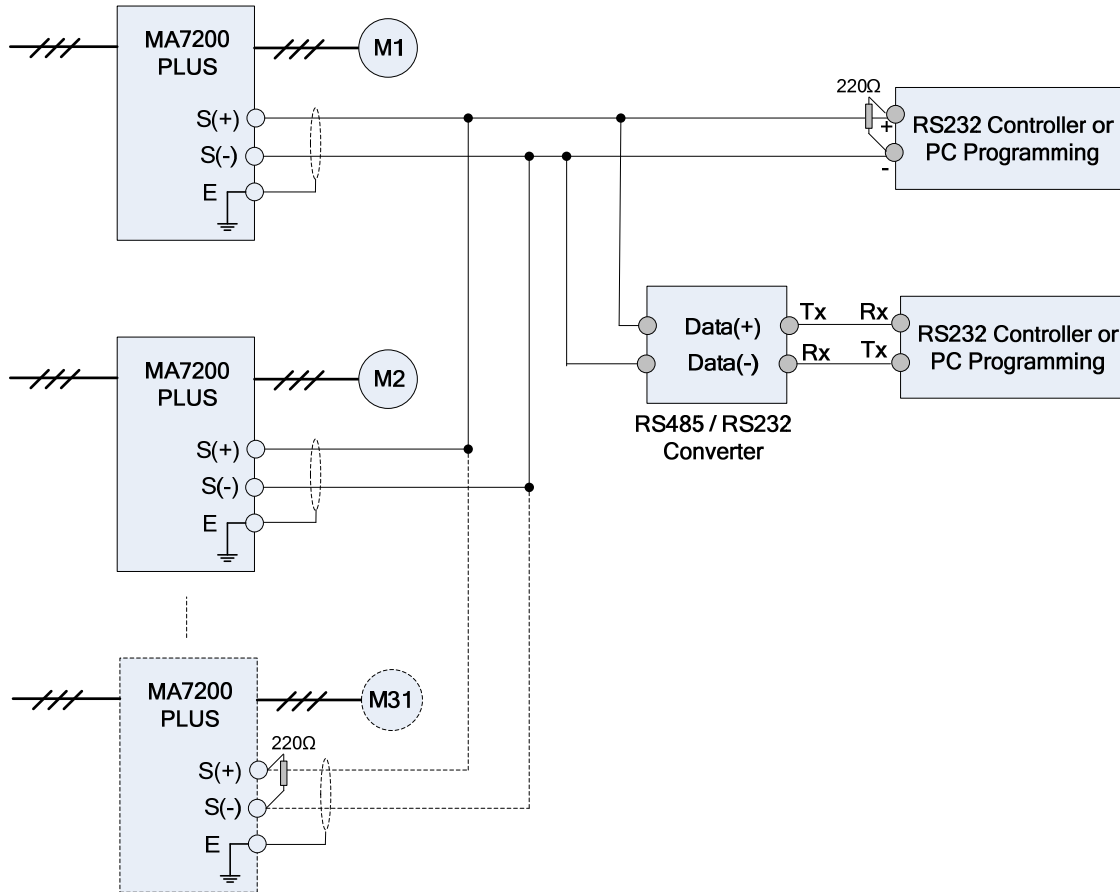

Fig. 4.2.5 MODBUS Interface Wiring

Notes:

1. A Host Controller with an RS485 interface can communicate with the MA7200 PLUS directly. If the Host Controller does not have an RS485 port but does have an RS-232 port (such as PC programming), an RS485 / RS232 converter can be used to connect between the Host Controller and the MA7200 PLUS as shown in Fig. 4.2.5.
2. A MODBUS Host Controller can network up to 31 inverters using the MODBUS communication standard. The last MA7200 PLUS inverter at the end of the network must have a 220Ω terminating resistor.
3. Please refer to “MA7200 RS485 MODBUS Communication Application Manual”.

B. PROFIBUS Communication Protocol

The MA7200 PLUS does not support the PROFIBUS protocol directly. An optional MA-SP PROFIBUS Communication Card is available and can be placed at the control board. An external customer supplied 24V DC Power Supply is needed for all MA-SP option cards. The following Fig. 4.2.6 shows the wiring interface for the PROFIBUS protocol.

Cont.

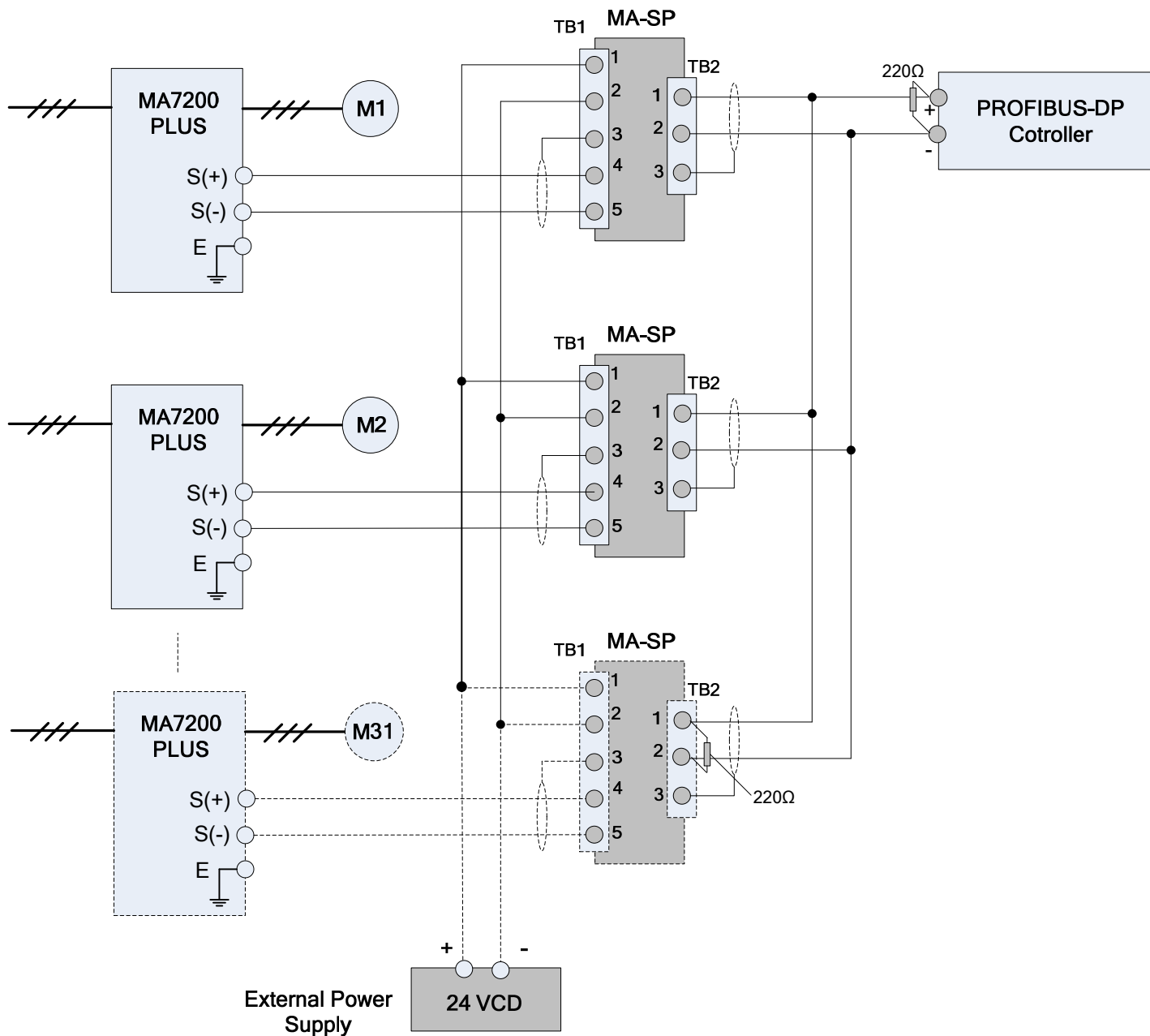

Fig. 4.2.6 PROFIBUS-DP Interface Wiring

Notes:

1. MA-SP Part Number: 4H300D0290009
2. Each station (Node) requires the use of the optional MA-SP interface card. Each card requires a power input of 24VDC @ 0.1A, so the external power supply needs to be sized accordingly.
3. A maximum of 31 PROFIBUS-DP stations (nodes) may be contained within a single network segment. The last MA-SP interface card on the drive at the end of the network, must have a 220Ω resistor between terminals 1 and 2.
4. For more details, refer to the “MA7200 PROFIBUS-DP Communication Application Manual”.

Table 4.2.1 Control Circuit Terminal Functions

Terminal	Functions
1 (D11)	Forward Operation – Stop Signal
2 (D12)	Reverse Operation – Stop Signal
3 (D13)	External Fault Input
4 (D14)	Fault Reset
5 (D15)	Multifunction Input Terminals: 3-Wire operation, Local / Remote control, Multi-Speed select, FWD / REV select, ACC / DEC select, ACC / DEC inhibit, Halting, Base Block, Overheat warning, PID control, DC braking, Speed search, Up / Down function, PG feedback control, External fault, Timer function, Multifunction analog Input setting. (See Parameter Section for details)
6 (D16)	
7 (D17)	
8 (D18)	
DG (SC)	Digital signal ground (230V: 1 - 2HP and 460V: 1 - 2HP models Only)
(24VG)	Sink Common Point (Set Jumper TP2 to SINK position) (230V: 3 - 40HP and 460V: 3 - 75HP models Only)
24V	Source Common Point (Set jumper TP2 to SOURCE position) (230V: 3 - 40HP and 460V: 3 - 75HP models Only)
E	Connection for signal shield lead (Chassis Ground)
+12V	DC voltage for External Device
-12V	Only supported in the (230V: 3 - 40HP, 460V: 3 - 75HP and 575V: 1-10HPmodels Only)
VIN	Master speed Voltage Reference (0 - 10V) (Models above 2HP supports(-10V - 10V input)
AIN	Master speed Current Reference (4 - 20mA)
AUX	Auxiliary Analog Input: Auxiliary frequency command, Frequency gain, Frequency bias, Excess load detection, Output voltage bias, ACC / DEC ramp, DC-Brake current, Stall prevention current level during running, PID Control, Frequency command Lower-Bound, Frequency – Jump - 4, etc. (See Parameter Section for details)
GND	Analog Signal Common
IP12	External Power Source For PG Feedback (Set TP1 to PULL UP for external power source)
IG12	
A(+)	Signal Input from PG (Can also be used as the input terminals for a Pulse Input Frequency Command)
A(-)	
AO1	Analog Multifunction Output Port: Frequency command, Output frequency, Output current, Output voltage, DC voltage, PID controlled value, Analog command input of VIN, AIN or AUX.(Output current < 2mA) (See Parameter Section for details)
AO2	
GND	Analog Common
RA(R2A)	Relay Contacts, RA, RB and RC (230V: 1 - 2HP and 460V: 1 - 2HP models Only)
RB(R2B)	Relay Contacts R2A, R2B and R2C (230V: 3 - 40HP and 460V: 3 - 75HP models Only)
RC(R2C)	DO1 Open Collector transistor (All)
R1B	DO2 Open Collector transistor (230V: 1 - 2HP and 460V: 1 - 2HP models Only)
R1C	Functions:
DO1	During-Running, Zero-speed, Agree-frequency, Agree-frequency-setting, Frequency-output, Inverter-operation-ready, Undervoltage-detection, Base-block output, Run source, Frequency command, Excess load detection, Frequency command invalid, Fault, Undervoltage, Overheat, Motor overload, Inverter overload, During-retry, Communication-fault, Timer-function-output. (See Parameter Section for details)
DO2	
DOG	Common Terminal (Open collector transistor outputs)
S(+)	RS-485 Port
S(-)	

⚠ CAUTION

- Use the control circuit terminals VIN, AIN according the setting of parameter Sn-24.
- The MAX. Output current at terminal (+24V or +12V) is 20mA.
- The multi-function analog output terminals AO1, AO2 are dedicated outputs to monitor frequency, amps, etc. Do not use these 2 analog outputs for feedback control or any other control purpose.

5.0 Peripheral Power Devices Overview

The following Fig. 5.0.1 describes some of the precautions that should be followed when selecting peripheral power devices.

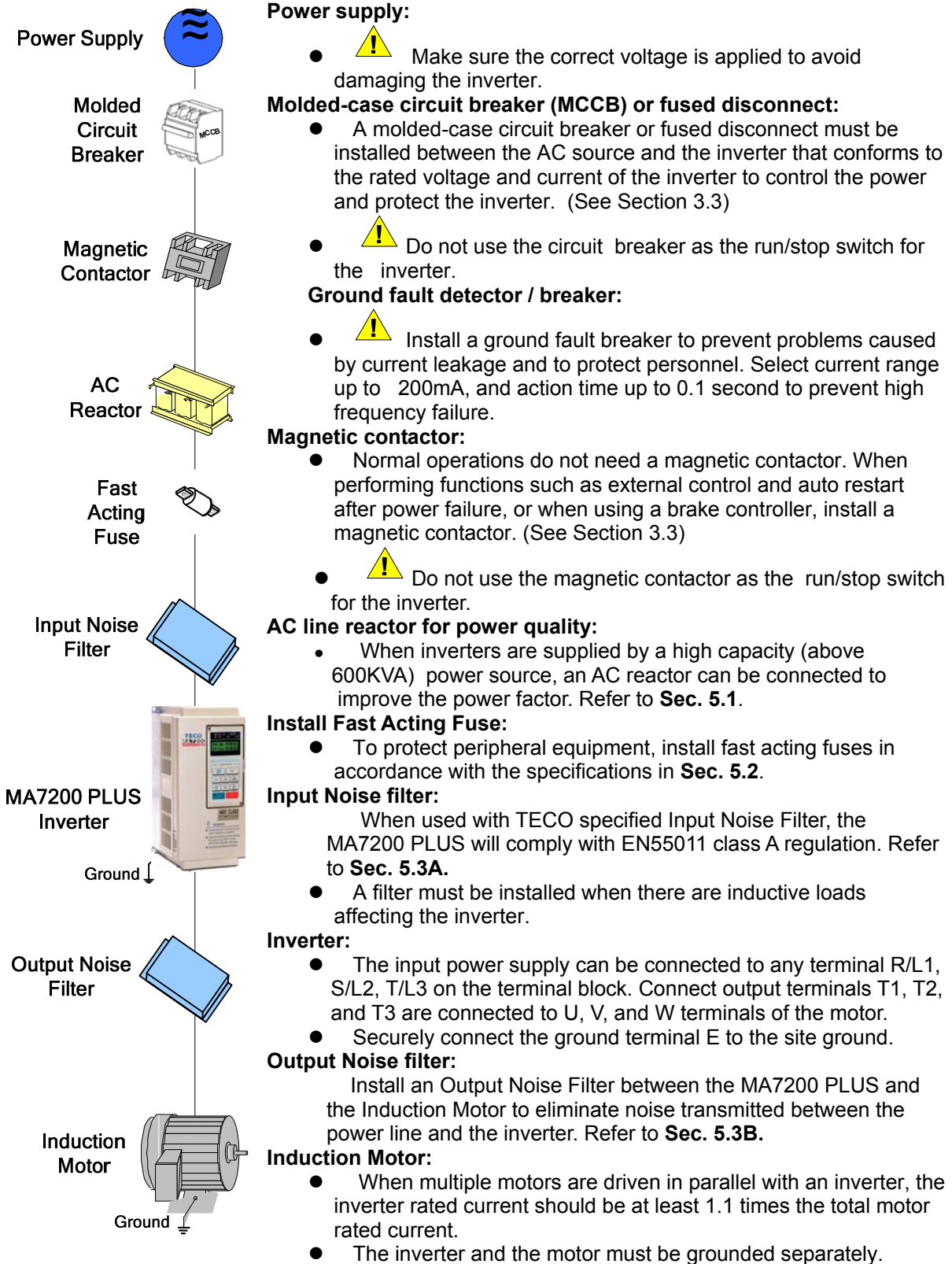

Fig. 5.0.1 Peripheral Power Devices Overview

5.1 AC Input Reactor

An AC reactor can be added on the input power supply side if the inverter is connected to a much larger capacity power supply system (above 600KVA), or the inverter is within short distance (< 38.2 ft. (10m)) from the power supply system, or to increase the power factor on the power supply side.

Table 5.1.1 below shows the AC Reactor ratings, specifications, and the TECO part number for the various MA7200 PLUS horsepower ratings

Table 5.1.1 AC Reactor Ratings and Specifications

Inverter Ratings			AC reactor	
Voltage	HP	Rated current	Part No.	Specification (mH/A)
230V 1Φ / 3Φ	1	4.8A	3M200D1610021	2.1mH / 5A
	2	6.5A	3M200D1610030	1.1mH / 10A
	3	9.6A	3M200D1610048	0.71mH / 15A
230V 3Φ	5.4	17.5A	3M200D1610056	0.53mH / 20A
	7.5	24A	3M200D1610064	0.35mH / 30A
	10	32A	3M200D1610072	0.265mH / 40A
	15	48A	3M200D1610081	0.18mH / 60A
	20	64A	3M200D1610099	0.13mH / 80A
	25	80A	3M200D1610102	0.12mH / 90A
	30	96A	3M200D1610111	0.09mH / 120A
460V 3Φ	40	130A	3M200D1610269	0.07mH / 160A
	1	2.6A	3M200D1610137	8.4mH / 3A
	2	4A	3M200D1610145	4.2mH / 5A
	3	4.8A	3M200D1610153	3.6mH / 7.5A
	5.4	8.7A	3M200D1610161	2.2mH / 10A
	7.5	12A	3M200D1610170	1.42mH / 15A
	10	15A	3M200D1610188	1.06mH / 20A
	15	24A	3M200D1610196	0.7mH / 30A
	20	32A	3M200D1610200	0.53mH / 40A
	25	40A	3M200D1610218	0.42mH / 50A
	30	48A	3M200D1610226	0.36mH / 60A
	40	64A	3M200D1610234	0.26mH / 80A
	50	80A	3M200D1610242	0.24mH / 90A
60	96A	3M200D1610251	0.18mH / 120A	
75	128A	3M200D1610315	0.15mH / 150A	
575V 3Φ	1	1.7A	?	13.5mH / 3A
	2	3.0A	?	7.6mH / 5A
	3	4.2A	?	5.4mH / 7.5A
	5	6.6A	?	3.5mH / 10A
	7.5	9.9A	?	2.3mH / 15A
	10	12.2A	?	1.9mH / 15A

Note: The AC reactors are applied only to input side of the inverter. **Do not** apply to the output side.

5.2 Input Fuse Types and Ratings

The following Table 5.2.1 shows the fuse types and rating for the various voltage classes and horsepower.

Table 5.2.1 Input Fuse Types and Ratings

230V Class

Fuse Part Number	HP	KVA	100% Cont. Output AMPS	Rated Input AMPS	3Φ Fuse Rating	1Φ Fuse Rating
JNTMBG□□0001JK	1	2	4.8	6	12	15
JNTMBG□□0002JK	2	2.7	6.4	8	15	20
JNTMBG□□0003JK	3	4	9.6	12	20	25
JNTMBG□□0005JK	5	7.5	17.5	21	30	x
JNTMBG□□7R50JK	7.5	10.1	24	29	50	x
JNTMBG□□0010JK	10	13.7	32	38	60	x
JNTMBG□□0015JK	15	20.6	48	58	100	x
JNTMBG□□0020JK	20	27.4	64	77	125	x
JNTMBG□□0025JK	25	34	80	88	125	x
JNTMBG□□0030JK	30	41	96	106	150	x
JNTMBG□□0040JK	40	54	130	143	200	x

460V Class

Fuse Part Number	HP	KVA	100% Cont. Output AMPS	Rated Input AMPS	Fuse Rating
JNTMBG□□0001AZ	1	2.2	2.6	3	6
JNTMBG□□0002AZ	2	3.4	4	5	10
JNTMBG□□0003AZ	3	4.1	4.8	6	10
JNTMBG□□0005AZ	5	7.5	8.7	10	20
JNTMBG□□7R50AZ	7.5	10.3	12	14	25
JNTMBG□□0010AZ	10	12.3	15	18	30
JNTMBG□□0015AZ	15	20.6	24	29	50
JNTMBG□□0020AZ	20	27.4	32	38	60
JNTMBG□□0025AZ	25	34	40	48	70
JNTMBG□□0030AZ	30	41	48	53	80
JNTMBG□□0040AZ	40	54	64	70	100
JNTMBG□□0050AZ	50	68	80	88	125
JNTMBG□□0060AZ	60	82	96	106	150
JNTMBG□□0075AZ	75	110	128	141	200

575V Class

Fuse Part Number	HP	KVA	100% Cont. Output AMPS	Rated Input AMPS	Fuse Rating
JNTMBG□□0001AX	1	1.7	1.7	2.2	5
JNTMBG□□0002AX	2	3.0	3.0	3.75	8
JNTMBG□□0003AX	3	4.2	4.2	5.25	10
JNTMBG□□0005AX	5	6.6	6.6	8.25	25
JNTMBG□□7R50AX	7.5	9.9	9.9	12.414	25
JNTMBG□□0010AX	10	12.2	12.2	15.25	30

Fuse Type: UL designated SEMICONDUCTOR PROTECTION FUSES

Class: CC, J, T, RK1 or RK5

Voltage Range: 300V for 230V class VFD; 500V for 460V class VFD

6.3 Noise Filters

A. Input Noise Filter

Install a noise filter on power supply side to eliminate noise transmitted between the power line and the inverter. The MA7200 PLUS noise filter shown in Table 5.3.1 below meets the EN61800-3 class A specification.

Table 5.3.1 Input Noise Filter Specifications and Ratings

Inverter Rating			Noise Filter				
Voltage	HP	Rated Current (A)	Code		Specifications	Current	*Dimensions
230V 1 / 3Φ	1	4.8A	1Φ	4H300D1750003	JUNF12015S-MA	15 A	Fig.5.3.1a
			3Φ	4H300D1710001	JUNF32012S-MA	12 A	Fig.5.3.1a
	2	6.5A	1Φ	4H300D1750003	JUNF12015S-MA	15 A	Fig.5.3.1a
			3Φ	4H300D1710001	JUNF32012S-MA	12 A	Fig.5.3.1a
	3	9.6A	1Φ	4H300D1600001	JUNF12020S-MA	20 A	Fig.5.3.1a
			3Φ	4H300D1610007	JUNF32024S-MA	24 A	Fig.5.3.1a
230V 3Φ	5	17.5A	4H300D1610007		JUNF32024S-MA	24 A	Fig.5.3.1a
	7.5	24A	4H300D1620002		JUNF32048S-MA	48 A	Fig.5.3.1b
	10	32A	4H300D1620002		JUNF32048S-MA	48 A	Fig.5.3.1b
	15	48A	4H300D1730002		JUNF32070S-MA	70 A	Fig.5.3.1b
	20	64A	4H300D1730002		JUNF32070S-MA	70 A	Fig.5.3.1b
460V 3Φ	1	2.6A	4H300D1720007		JUNF34008S-MA	8 A	Fig.5.3.1a
	2	4A	4H300D1720007		JUNF34008S-MA	8 A	Fig.5.3.1a
	3	4.8A	4H300D1630008		JUNF34012S-MA	12 A	Fig.5.3.1a
	5	8.7A	4H300D1630008		JUNF34012S-MA	12 A	Fig.5.3.1a
	7.5	12A	4H300D1640003		JUNF34024S-MA	24 A	Fig.5.3.1b
	10	15A	4H300D1640003		JUNF34024S-MA	24 A	Fig.5.3.1b
	15	24A	4H300D1740008		JUNF34048S-MA	48 A	Fig.5.3.1b
	20	32A	4H300D1740008		JUNF34048S-MA	48 A	Fig.5.3.1b
	25	40A	4H000D1770008		KMF370A	70 A	Fig.5.3.1c
	30	48A	4H000D1790009		KMF370A	70 A	Fig.5.3.1c
	40	64A	4H000D1790009		KMF3100A	100 A	Fig.5.3.1c
	50	80A	4H000D1800004		KMF3100A	100 A	Fig.5.3.1c
	60	96A	4H000D1800004		KMF3150A	150 A	Fig.5.3.1c
	75	128A	4H000D1820005		KMF3180A	180 A	Fig.5.3.1c
575V 3Φ	1	1.7A	4H300D1720007		JUNF34008S-MA	8 A	Fig.5.3.1a
	2	3.0A	4H300D1720007		JUNF34008S-MA	8 A	Fig.5.3.1a
	3	4.2A	4H300D1630008		JUNF34012S-MA	12 A	Fig.5.3.1a
	5	6.6A	4H300D1630008		JUNF34012S-MA	12 A	Fig.5.3.1a
	7.5	9.9A	4H300D1640003		JUNF34024S-MA	24 A	Fig.5.3.1b
	10	12.2A	4H300D1640003		JUNF34024S-MA	24 A	Fig.5.3.1b

* Dimensions on following page

Cont.

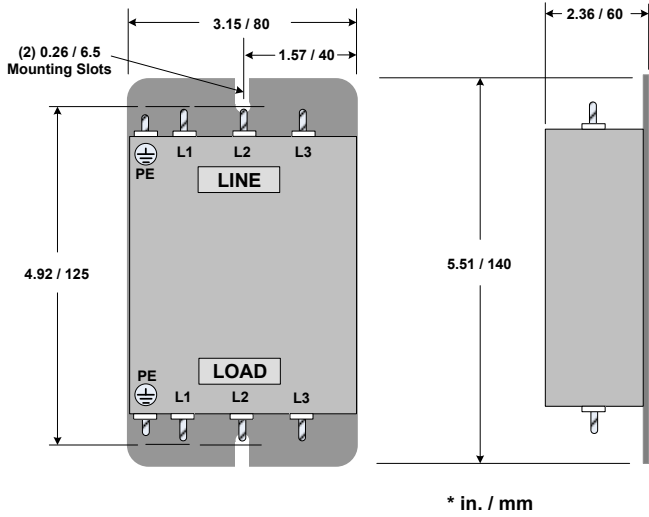

Fig. 5.3.1a

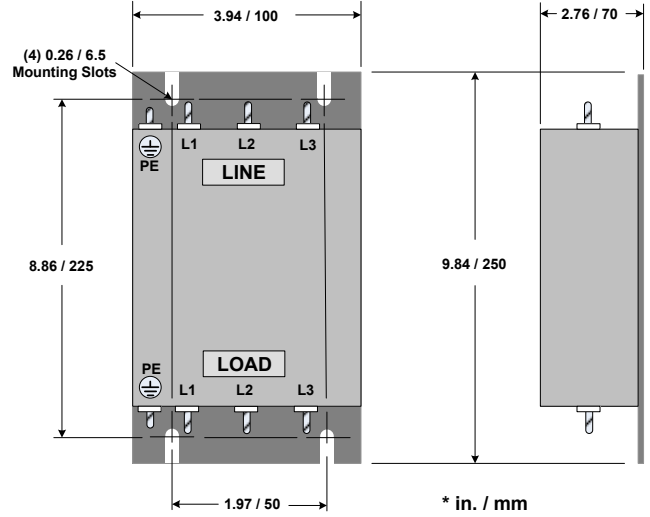

Fig. 5.3.1b

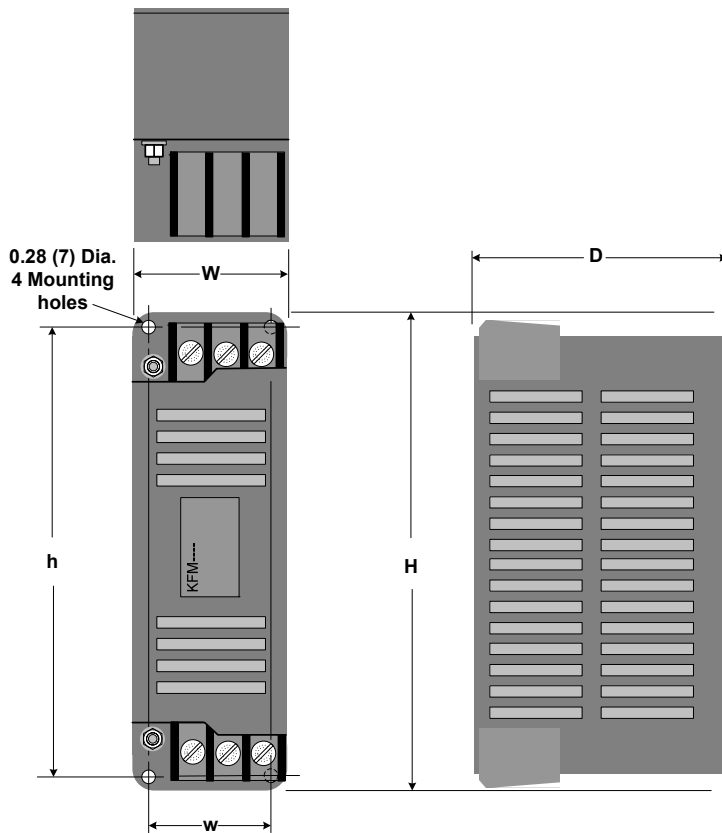

Fig. 5.3.1c

Model	KMF Dimensions in. (mm)				
	W	w	H	h	D
KMF37	3.66	3.11	12.3	11.7	7.48
KMF31	(93)	(79)	(312)	(298)	(190)
KMF31	4.96	4.41	12.3	11.7	8.82
KMF31	(126)	(112)	(312)	(298)	(224)

Fig. 5.3.1 Input Filter Dimensions

B. Input or Output Noise Filter (EMI Suppression Zero Phase Core)

Model: JUNFOC046S ----- Code No.: 4H000D0250001

Select a matched ferrite core to suppress EMI noise according to the required power rating and wire size.

The ferrite core can attenuate high frequencies in the range of 100kHz to 50MHz, as shown in Fig 5.3.2 below, and therefore should minimize the RFI generated by the inverter.

The zero-sequence noise ferrite core can be installed either on the input side or on the output side. The wire around the core for each phase should be wound by following the same convention and in one direction. The more turns without resulting in saturation the better the attenuation. If the wire size is too large to be wound, all the wiring can be grouped and put through several cores together in one direction.

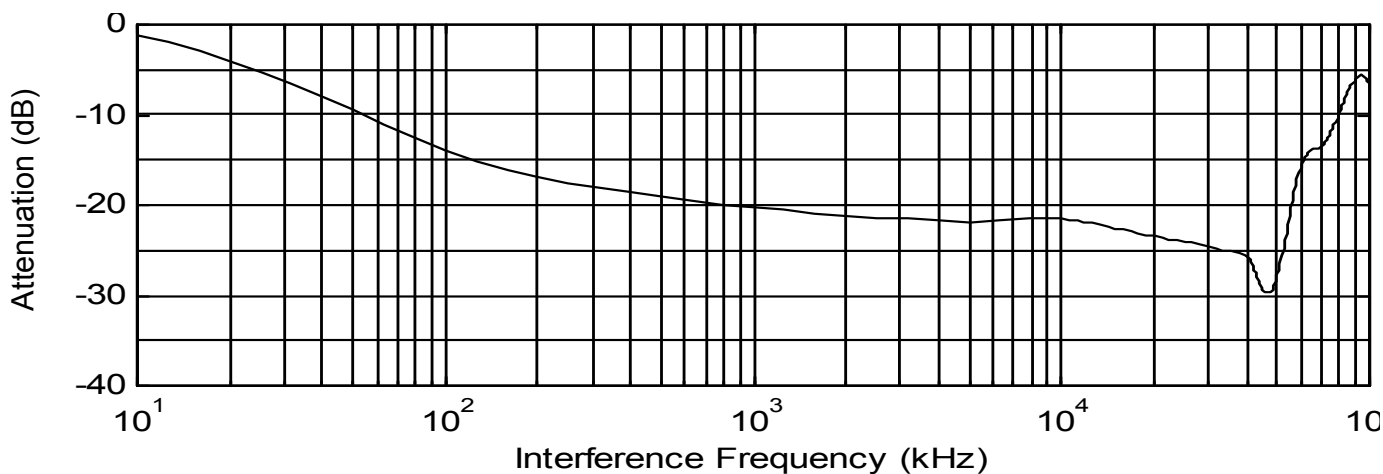

Fig. 5.3.2 Frequency attenuation characteristics (10 windings case)

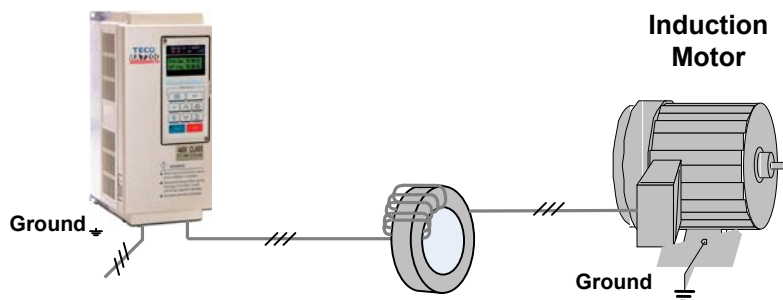

Fig. 5.3.3 Example of EMI Suppression Zero Phase Core Application

Note: All the wiring of phases U/T1, V/T2, W/T3 must pass through the same zero-phase core without crossing over.

6.4 Braking Resistors and Braking Units

The MA7200 PLUS 230V/460V, 1 - 20HP and 575V, 1-10HP models, have a built-in braking transistor and an external braking resistor can be connected between terminals B1/P and B2. For models above 25HP, connect a braking unit to terminals ⊕ - ⊖ of the inverter and connect the braking resistor(s) to terminals B-P0 of the braking unit.

Table 5.4.1 Braking Unit and Braking Resistor Ratings and Specifications

Inverter Rating			Braking Unit		Braking Resistor			Braking Torque (%)
Voltage	HP	Rated current (A)	Model	Number used	Code NO.	Specs.	Number used	
230V 1 / 3Φ	1	4.8	-	-	JNBR-150W200	150W/200Ω	1	119%, 10%ED
	2	6.4	-	-	JNBR-150W100	150W/100Ω	1	119%, 10%ED
	3	9.6	-	-	JNBR-260W70	260W/70Ω	1	115%, 10%ED
230V 3Φ	5	17.5	-	-	JNBR-390W40	390W/40Ω	1	119%, 10%ED
	7.5	24	-	-	JNBR-520W30	520W/30Ω	1	108%, 10%ED
	10	32	-	-	JNBR-780W20	780W/20Ω	1	119%, 10%ED
	15	48	-	-	JNBR-2R4KW13R6	2400W/13.6Ω	1	117%, 10%ED
	20	64	-	-	JNBR-3KW10	3000W/10Ω	1	119%, 10%ED
	25	80	JNTBU-230	1	JNBR-4R8KW8	4800W/8Ω	1	119%, 10%ED
	30	96	JNTBU-230	1	JNBR-4R8KW6R8	4800W/6.8Ω	1	117%, 10%ED
40	130	JNTBU-230	2	JNBR-3KW10	3000W/10Ω	2	119%, 10%ED	
460V 3Φ	1	2.6	-	-	JNBR-150W750	150W/750Ω	1	126%, 10%ED
	2	4	-	-	JNBR-150W400	150W/400Ω	1	119%, 10%ED
	3	4.8	-	-	JNBR-260W250	260W/250Ω	1	126%, 10%ED
	5	8.7	-	-	JNBR-400W150	400W/150Ω	1	126%, 10%ED
	7.5	12	-	-	JNBR-600W130	600W/130Ω	1	102%, 10%ED
	10	15	-	-	JNBR-800W100	800W/100Ω	1	99%, 10%ED
	15	24	-	-	JNBR-1R6KW50	1600W/50Ω	1	126%, 10%ED
	20	32	-	-	JNBR-1R5KW50	1500W/40Ω	1	119%, 10%ED
	25	40	JNTBU-430	1	JNBR-4R8KW32	4800W/32Ω	1	119%, 10%ED
	30	48	JNTBU-430	1	JNBR-4R8KW27R2	4800W/27.2Ω	1	117%, 10%ED
	40	64	JNTBU-430	1	JNBR-6KW20	6000W/20Ω	1	119%, 10%ED
	50	80	JNTBU-430	2	JNBR-4R8KW32	4800W/32Ω	2	119%, 10%ED
	60	96	JNTBU-430	2	JNBR-4R8KW27R2	4800W/27.2Ω	2	117%, 10%ED
75	128	JNTBU-430	2	JNBR-6KW20	6000W/20Ω	2	126%, 10%ED	
575V 3Φ	1	1.7	-	-	JNBR-260W250	260W/250Ω	1	126%, 10%ED
	2	3.0	-	-	JNBR-260W250	260W/250Ω	1	126%, 10%ED
	3	4.2	-	-	JNBR-260W250	260W/250Ω	1	126%, 10%ED
	5	6.6	-	-	JNBR-400W150	400W/150Ω	1	126%, 10%ED
	7.5	9.9	-	-	JNBR-600W130	800W/100Ω	1	170%, 9%ED
	10	12.2	-	-	JNBR-800W100	800W/100Ω	1	125%, 9%ED

Note 1: Alternate choices: 440V 50HP (JUVPHV-0060+JNBR-9R6KW16) x 1;
440V 60HP : (JUVPHV-0060+JNBR- 9R6KW13R6) x 1

Note 2: JUVPHV-0060 no UL certification

Note 3: When set up the braking unit and resistor, please make sure there is adequate ventilation.

6.0 Peripheral Control Devices

6.1 CD Operator with Extension Cable

When used for remote control purposes, the LCD operator can be removed and remotely connected with an extension cable. Some of the available extension cable lengths are listed in the following Table 6.1.1.

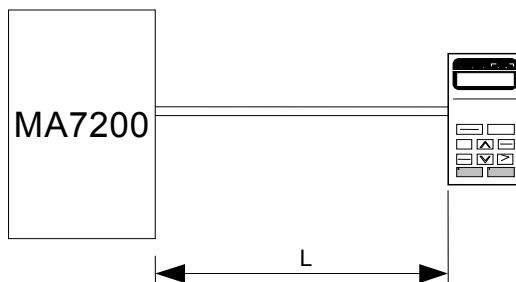

Table 6.1.1 Digital Operator Cable Extensions

Cable Length L In. / m	Extension Cable Set *1 P/N	Extension Cable *2 P/N	Blank Cover *3 P/N
3.28 / 1	4H332D0010000	4H314C0010003	4H300D1120000
6.56 / 2	4H332D0030001	4H314C0030004	
9.84 / 3	4H332D0020005	4H314C0020009	
16.4 / 5	4H332D0040006	4H314C0040000	
32.8 / 10	4H332D0130005	4H314C0060001	

*1: Includes the extension cable for the LCD digital operator, blank cover, screws and installation manual.

*2: Extension cable for LCD digital operator.

*3: B blank cover to protect against external dusts, metallic powder, etc.

The following Fig.6.1.1 shows the dimensional information for the remote mounting of the Digital Operator.

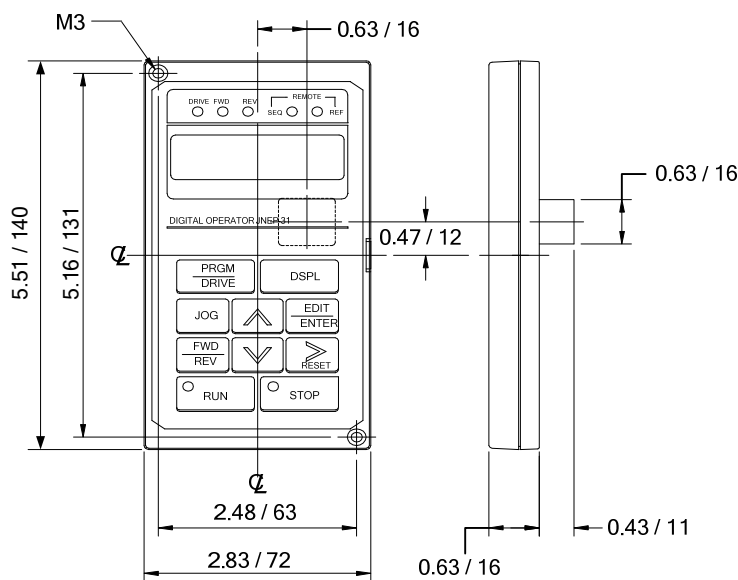

Fig. 6.1.1 LCD Digital Operator Dimension

6.4 Analog Operator

All MA7200 PLUS inverters are supplied with a Digital Operator. An Analog Operator, P/N JNEP-16 shown below in Fig. 6.2.1 is also available and can be connected as a portable operator. The wiring diagram is also shown.

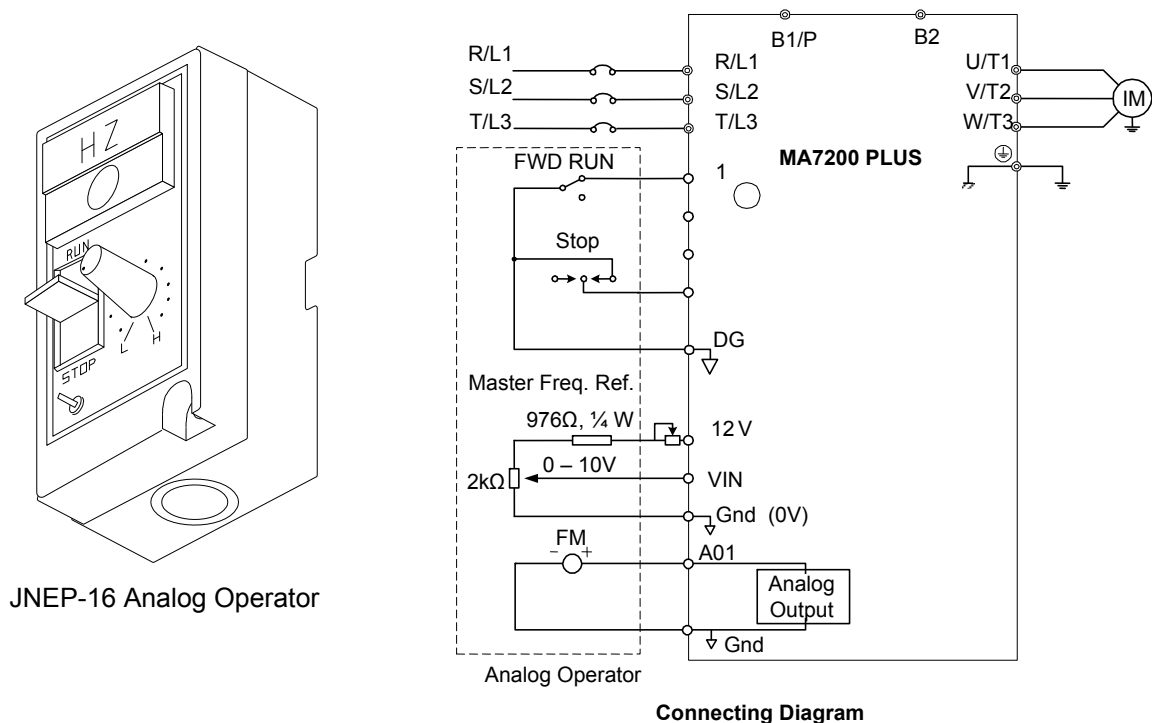

Fig. 6.2.1 Analog Operator Outline and Wiring Diagram

6.5 PROFIBUS Communication Card

Part No. : 4H300D0290009

Refer to the previous Section 4.1 (6) B and the “MA7200 PROFIBUS-DP Communication Application Manual” for Communication interface details.

NOTES-

7.0 MA7200 PLUS Specifications

7.1 Basic Specifications

The basic specifications for each voltage series are shown in the following Tables 7.1.1a - c.

Table 7.1.1a 230V Series

Inverter (HP)		1	2	3	5	7.5	10	15	20	25	30	40
Max. Applicable Motor Output HP ^{*1} (KW)		1 (0.75)	2 (1.5)	3 (2.2)	5.4 (4)	7.5 (5.5)	10 (7.5)	15 (11)	20 (15)	25 (18.5)	30 (22)	40 (30)
Output Characteristics	Rated Output Capacity (KVA)	2	2.7	4	7.5	10.1	13.7	20.6	27.4	34	41	54
	Rated Output Current (A)	4.8	6.4	9.6	17.5	24	32	48	64	80	96	130
	Max. Output Voltage (V)	3-Phase, 200V - 240V										
	Max. Output Frequency (Hz)	Using Parameter Setting 0.1- 400.0 Hz										
Power Supply	Rated Voltage, Frequency	1PH / 3PH 200V - 240V, 50/60Hz			3-Phase, 200V - 240V, 50/60Hz							
	Allowable Voltage Fluctuation	-15% - +10%										
	Allowable Frequency Fluctuation	± 5%										

Table 7.1.1b 460V Series

Inverter (HP)		1	2	3	5	7.5	10	15	20	25	30	40	50	60	75
Max. Applicable Motor Output HP ^{*1} (KW)		1 (0.75)	2 (1.5)	3 (2.2)	5.4 (4)	7.5 (5.5)	10 (7.5)	15 (11)	20 (15)	25 (18.5)	30 (22)	40 (30)	50 (37)	60 (45)	75 (55)
Output Characteristics	Rated Output Capacity (KVA)	2.2	3.4	4.1	7.5	10.3	12.3	20.6	27.4	34	41	54	68	82	110
	Rated Output Current (A)	2.6	4	4.8	8.7	12	15	24	32	40	48	64	80	96	128
	Max. Output Voltage (V)	3-Phase, 380V - 480V													
	Max. Output Frequency (Hz)	Using Parameter Setting 0.1 - 400.0 Hz													
Power Supply	Rated Voltage, Frequency	3-Phase, 380V - 480V, 50/60Hz													
	Allowable Voltage Fluctuation	-15% - +10%													
	Allowable Frequency Fluctuation	± 5%													

Cont.

Table 7.1.1c 575V Series

Inverter (HP)		1	2	3	5	7.5	10
Max. Applicable Motor Output HP* ¹ (KW)		1 (0.75)	2 (1.5)	3 (2.2)	5.4 (4)	7.5 (5.5)	10 (7.5)
Output Characteristics	Rated Output Capacity (KVA)	1.7	3.0	4.2	6.6	9.9	12.2
	Rated Output Current (A)	1.7	3.0	4.2	6.6	9.9	12.2
	Max. Output Voltage (V)	3-Phase: 500 / 550 - 600VAC					
	Max. Output Frequency (Hz)	Using Parameter Setting 0.1 - 400.0 Hz					
Power Supply	Rated Voltage, Frequency	3-Phase, 500 - 600VAC, 50/60Hz					
	Allowable Voltage Fluctuation	-15% - +10%					
	Allowable Frequency Fluctuation	± 5%					

*1. Based on 4 pole motor

*2. The specifications for NEMA4 are the same.

NOTES-

7.4 General Specifications

The following Table 7.2.1 shows the general specifications for the MA7200 PLUS series.

Cont.

Table 7.2.1- General Specifications

Control Characteristics	Operation Mode	Graphic LCD Panel (English only) with parameters copying
	Control Mode	Sinusoidal PWM
	Frequency Control Range	0.1Hz - 400Hz
	Frequency Accuracy (varied with temperature)	Digital Command: $\pm 0.01\%$ (-10 - +40°C), Analog Command: $\pm 0.1\%$ (25°C \pm 10°C),
	Speed Control Accuracy	$\pm 0.1\%$ (V/F with PG feedback); $\pm 0.5\%$ (Sensorless Vector Control)
	Frequency Command Resolution	Digital Command: 0.01Hz; Analog Command: 0.06Hz / 60Hz
	Frequency Output Resolution	0.01Hz
	Overload Resistibility	150% Rated Current for 1 Min
	Frequency Setting Signal	DC 0 - +10V / 4 - 20 mA, DC-10V - +10V and Pulse Input Frequency Command (Above 230V / 460V, 25HP and 575V, 1-10 HP)
	Acc./ Dec. Time	0.0 - 6000.0 sec. (Accel / Decel Time Can Be Set Independently)
	Voltage-Frequency Characteristics	V/F Curve Can Be Selected Through Parameter Setting
	Regeneration Torque	Approx. 20%
	Basic Control Function	Restart After Momentary Power Loss, PID Control, Auto Torque Boost, Slip Compensation, RS485 Communication, Speed Feedback Control, Simple PLC function and 2 Analog Output Port.
	HVAC Function	Programmable Local / Remote Key, Engineering Unit Display, PID Sleep Function, External PID Function, Over / Low Feedback Detection, Low Suction Detection, Flow Meter Display via Analog Input or Pulse Input, Power Meter, kWh Meter and Energy Cost Usage.
Additional Functions	Cumulative Power on & Operation Hour memory, Energy Saving, Up / Down Operation, 4 Different sets of Fault Status Record (Including Latest one), MODBUS Communication, Multiple-Pulse Output Ports, Select Local / Remote, SINK / SOURCE Interface.	
Protection Function	Stall Prevention	During Acceleration / Deceleration and constant Running Speed (Current Level Can Be Selected During Acceleration and Constant Running Speed. During Deceleration, Stall Prevention Can Be Enabled or Disabled)
	Instantaneous Overcurrent	Turns Off if above 200% Rated Current
	Motor Overload Protection	Electronic Overload Curve Protection
	Inverter Overload Protection	Turns Off if above 150% Rated Current for 1 Min.
	Overvoltage	Stop if VDC>410V (230 Class), VDC>820V (460 Class) or VDC>1050V (575 Class)
	Undervoltage	Stop if VDC<200V (230 Class), VDC<400V (460 Class) or VDC<546V (575 Class)
	Momentary Power Loss Ride-Through time	<15ms, otherwise Stop
	Overheat Protection	Protected by Thermistor
	Grounding Protection	Protection by DC Current Sensor
	Charge Indication (LED)	ON when the DC Bus Voltage Above 50V
	Output Phase Loss (OPL)	Motor coasts to stop at Output Phase Loss
Environmental	Application Site	Indoor (No Corrosive Gas and Dust Present)
	Ambient Temperature	-10°C - +40°C (Not Frozen)
	Storage Temperature	-20°C - +60°C
	Ambient Humidity	< 90%RH (Non-Condensing)
	Altitude, Vibration	< 1000M; 5.9m/S ² (0.6G), (JISC0911 Standard)
	Communication Function	RS485 Installed (MODBUS Protocol); (Optional Profibus Card)
	Encoder Feedback Interface	Built-in PG Feedback Interface and set to Open-collector Interface Drive or Complementary Interface Drive
	EMI	Meets EN 61800-3 With Specified EMI Filter
	EMS Compatibility	Meets EN 61800-3

7.3 MA7200 PLUS Dimensions and Weights

Table 7.3.1- MA7300 PLUS Open Chassis and NEMA 1 Dimensions and Weights

Voltage Rating	Inverter Capacity (HP)	Open Chassis Type (IP00) In. (mm)						Wt. lb. (kg)	Enclosed Type (NEMA1) In. (mm)						Wt. lbs (kg)	ACL/DCL	Ref. Fig. 6.3.1										
		W	H	D	W1	H1	d		W	H	D	W1	H1	d													
230V 1 / 3Φ	1							-	5.2 (132)	8.54 (217)	5.65 (143.5)	4.80 (122)	8.15 (207)	M5	5.07 (2.3)	External ACL (optional)	(a)										
	2								5.51 (140)	11.0 (279.5)	6.95 (176.5)	4.96 (126)	10.5 (266)		9.48 (4.3)												
	3								5.51 (140)	11.0 (279.5)	6.95 (176.5)	4.96 (126)	10.5 (266)		9.48 (4.3)												
230V 3Φ	5							-	5.51 (140)	279.5	6.95 (176.5)	4.96 (126)	10.5 (266)	M6	9.48 (4.3)	External ACL (optional)	(b)										
	7.5								8.31 (211.2)	11.0 (279.5)	8.46 (215)	7.56 (192)	11.3 (286)		12.6 (5.7)												
	10								10.43 (265)	14.17 (360)	8.86 (225)	9.65 (245)	13.4 (340)		26.5 (12)												
	15								10.43 (265)	14.17 (360)	8.86 (225)	9.65 (245)	13.4 (340)		28.7 (13)												
	20								10.6 (269)	21.8 (553)	10.9 (277)	Top 8.27 (210) Bottom 7.1 (180)	20.9 (530)		M10			66.2 (30)	10.59 (269)	25.47 (647)	10.91 (277)	Top 8.27 (210) Bottom 7.1 (180)	20.9 (530)	M10	68.4 (31)	DCL Built- in (Standard)	(c)
	30								10.6 (269)	21.8 (553)	10.9 (277)	Top 8.27 (210) Bottom 7.1 (180)	20.9 (530)		M10			66.2 (30)	10.59 (269)	25.47 (647)	10.91 (277)	Top 8.27 (210) Bottom 7.1 (180)	20.9 (530)	M10	68.4 (31)		
	40								10.6 (269)	21.8 (553)	10.9 (277)	Top 8.27 (210) Bottom 7.1 (180)	20.9 (530)		M10			68.4 (31)	10.59 (269)	25.47 (647)	10.91 (277)	Top 8.27 (210) Bottom 7.1 (180)	20.9 (530)	M10	70.6 (32)		
460V 3Φ	1							-	5.2 (132)	8.54 (217)	5.65 (143.5)	4.80 (122)	8.15 (207)	M5	5.07 (2.3)	External ACL (option)	(a)										
	2								5.51 (140)	11.0 (279.5)	6.95 (176.5)	4.96 (126)	10.5 (266)		9.48 (4.3)												
	3								5.51 (140)	11.0 (279.5)	6.95 (176.5)	4.96 (126)	10.5 (266)		9.48 (4.3)												
	5								8.31 (211.2)	11.81 (300)	8.46 (215)	7.56 (192)	11.3 (286)		12.6 (5.7)												
	7.5								10.43 (265)	14.17 (360)	8.86 (225)	9.65 (245)	13.4 (340)		26.5 (12)												
	10								10.43 (265)	14.17 (360)	8.86 (225)	9.65 (245)	13.4 (340)		28.7 (13)												
	15								10.6 (269)	21.8 (553)	10.9 (277)	Top 8.27 (210) Bottom 7.1 (180)	20.9 (530)		M10			66.2 (30)	10.59 (269)	25.47 (647)	10.91 (277)	Top 8.27 (210) Bottom 7.1 (180)	20.9 (530)	M10	68.4 (31)	DCL Built- in (Standard)	(c)
	20								10.6 (269)	21.8 (553)	10.9 (277)	Top 8.27 (210) Bottom 7.1 (180)	20.9 (530)		M10			66.2 (30)	10.59 (269)	25.47 (647)	10.91 (277)	Top 8.27 (210) Bottom 7.1 (180)	20.9 (530)	M10	68.4 (31)		
	25								12.2 (308)	25.7 (653)	11.1 (282)	Top 9.84 (250) Bottom 8.66 (220)	24.8 (630)		M10			101.4 (46)	12.13 (308)	29.41 (747)	11.1 (282)	Top 9.84 (250) Bottom 8.66 (220)	24.8 (630)	M10	103.6 (47)		
	30								12.2 (308)	25.7 (653)	11.1 (282)	Top 9.84 (250) Bottom 8.66 (220)	24.8 (630)		M10			101.4 (46)	12.13 (308)	29.41 (747)	11.1 (282)	Top 9.84 (250) Bottom 8.66 (220)	24.8 (630)	M10	103.6 (47)		
	40								12.2 (308)	25.7 (653)	11.1 (282)	Top 9.84 (250) Bottom 8.66 (220)	24.8 (630)		M10			101.4 (46)	12.13 (308)	29.41 (747)	11.1 (282)	Top 9.84 (250) Bottom 8.66 (220)	24.8 (630)	M10	103.6 (47)		
575V 3Φ	1							-	5.51 (140)	11.0 (279.5)	6.95 (176.5)	4.96 (126)	10.5 (266)	M6	9.48 (4.3)	External ACL (option)	(b)										
	2								8.31 (211.2)	11.81 (300)	8.46 (215)	7.56 (192)	11.3 (286)		12.6 (5.7)												
	3								8.31 (211.2)	11.81 (300)	8.46 (215)	7.56 (192)	11.3 (286)		12.6 (5.7)												
	5								8.31 (211.2)	11.81 (300)	8.46 (215)	7.56 (192)	11.3 (286)		12.6 (5.7)												
	7.5								8.31 (211.2)	11.81 (300)	8.46 (215)	7.56 (192)	11.3 (286)		12.6 (5.7)												
	10								8.31 (211.2)	11.81 (300)	8.46 (215)	7.56 (192)	11.3 (286)		12.6 (5.7)												

Cont.

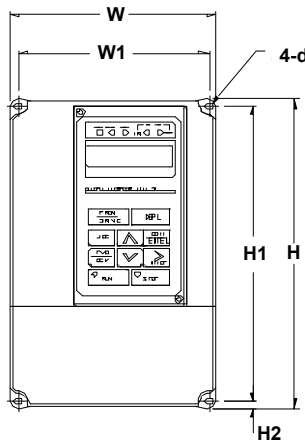

(a) 230V / 460V : 1- 2HP

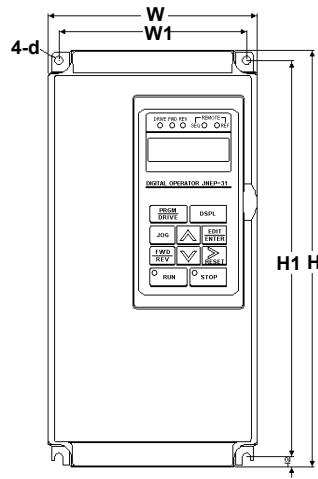
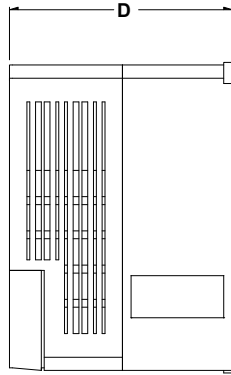

(b) 230V : 3HP- 25HP
460V : 3HP- 30HP
575V : 1HP- 10HP

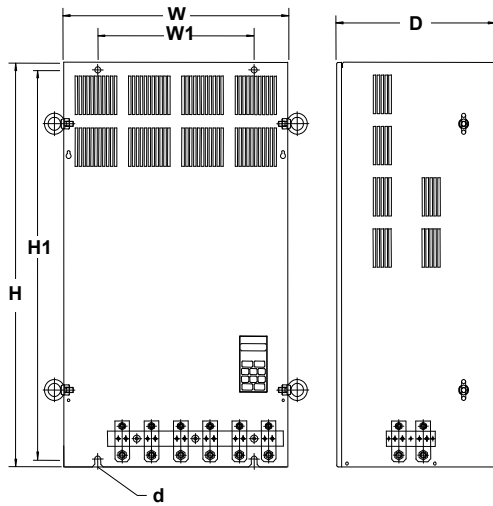
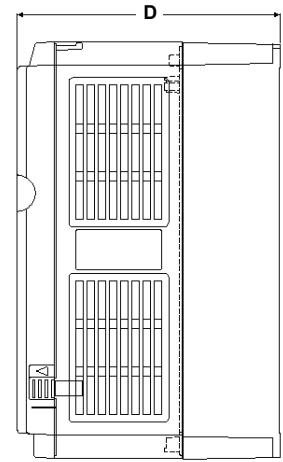

(Open Chassis Type - IP00)

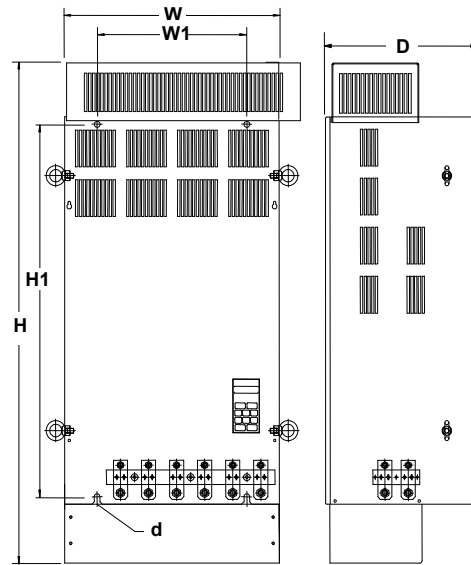

(Enclosed, Wall-mounted Type - NEMA1)

(c) 230V : 30HP - 40HP
460V : 40HP - 75HP

Fig. 7.3.1 Open Chassis and NEMA 1 Outlines

Table 7.3.2 MA7300 PLUS NEMA 4 Dimensions and Weights

Voltage	Inverter Capacity (HP)	NEMA4 In. (mm)						Weight Lbs. (kg)
		W	H	D	W1	H1	d	
230V 1/3Φ	1	7.80 (198)	13.2 (335)	8.54 (217)	4.53 (115)	12.4 (315)	M6	13.9 (6.3)
	2							16.6 (7.5)
	3							
230V 3Φ	5	8.78 (223)	18.1 (460)	9.65 (245)	5.51 (140)	17.32 (440)	M6	35.3 (16)
	7.5							
	10							
	15							
460V 3Φ	20	7.80 (198)	13.2 (335)	8.54 (217)	4.53 (115)	12.4 (315)	M6	13.9 (6.3)
	1							16.6 (7.5)
	3							
	5	8.78 (223)	18.1 (460)	9.65 (245)	5.51 (140)	17.32 (440)	M6	35.3 (16)
	7.5							
	10							
	15							
20								

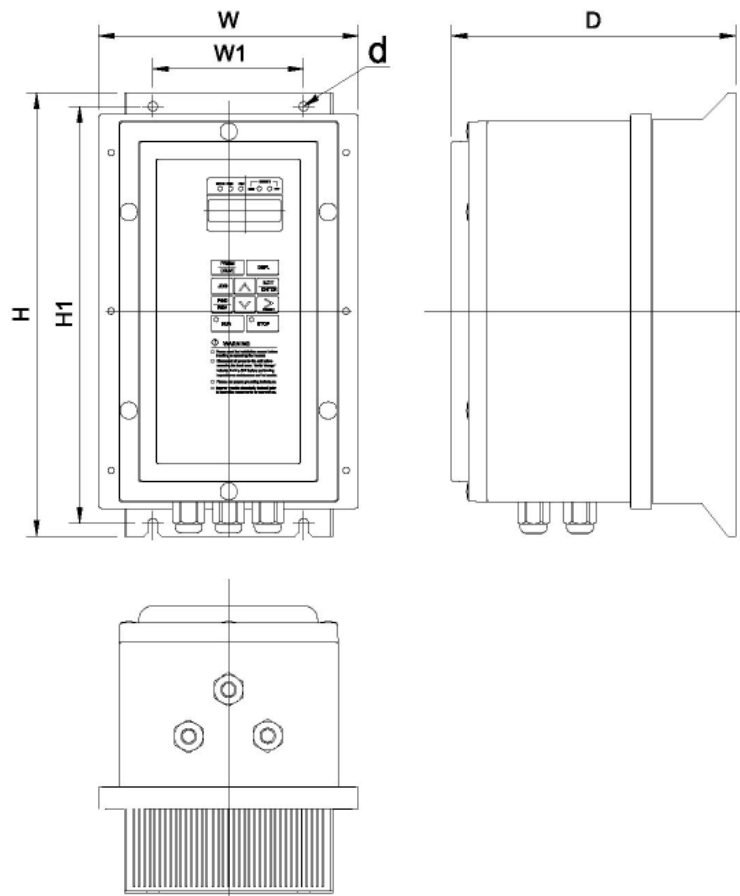

Fig. 7.3.2 and NEMA 4 Outline

8.0 Parameter Groups, Digital Operator, Menus and Keypad Navigation

8.1 Parameter Groups

The MA7200 PLUS has nine groups of user parameters and one monitor parameter group (Un-□□), that can not be changed by the user and is listed in the following Table 8.1.1. The parameters and values are accessed for setting and / or monitoring through the Digital Operator covered in Section 8.2. The parameter allowable settings and explanations are covered in detail in Section 9.0.

Table 8.1.1 Parameter Groups

Parameter	Description
An-□□	Frequency command
Bn-□□	Parameter group that can be changed during running
Sn-□□	System parameter group (Can be changes only after stop)
Cn-□□	Control parameter group (Can be changed only after stop)
P1-□□	HVAC parameter group (Can be changed only after stop)
P2-□□	HVAC parameter group (Can be changed during running)
P3-□□	HVAC parameter group (Can be changed only after stop)
P4-□□	HVAC parameter group (Can be changed only after stop)
P5-□□	HVAC parameter group (Can be changed during running)
Un-□□	Monitor group only (<i>There are no user settings for this group</i>)

The parameter setting of Sn – 03 (Operation Status) shown in Table 8.1.2 below determines if the values of the various parameter groups are allowed to be changed or can be monitored only.

Table 8.1.2 Sn-03 Setting

Sn-03	DRIVE mode		PRGM mode	
	Can be set	Monitored only	Can be set	Monitored only
0 *1	An,Bn,P2,P5	(Sn,Cn) ^{*2} , P1, P3, P4 ^{*3}	An, Bn, Sn, Cn, P1-P5	—
1	An	Bn, (Sn, Cn) ^{*2} P1-P5	An	Bn, Sn, Cn, P1-P5

*1 Factory setting

*2 When in the DRIVE mode, the parameter groups Sn- and Cn- can only be monitored if the RESET and the DSPL keys are to be pressed simultaneously.

*3 Parameters P4-01 to P4-04 can be monitored only during the DRIVE mode. Parameter P4-05 can be set and monitored during the DRIVE mode.

Note: After the required modifications have been made, it is recommended that parameter SN-03 be set to 1 to prevent unwanted modifications to parameter groups other than An- (Frequency Command).

8.2 Digital Operator Layout and Description

The JNEP-36 LCD Digital Operator shown in Fig. 8.2.1 has a 2 line by 20 character LCD English display, LED status indicators and a membrane keypad for control and data entry.

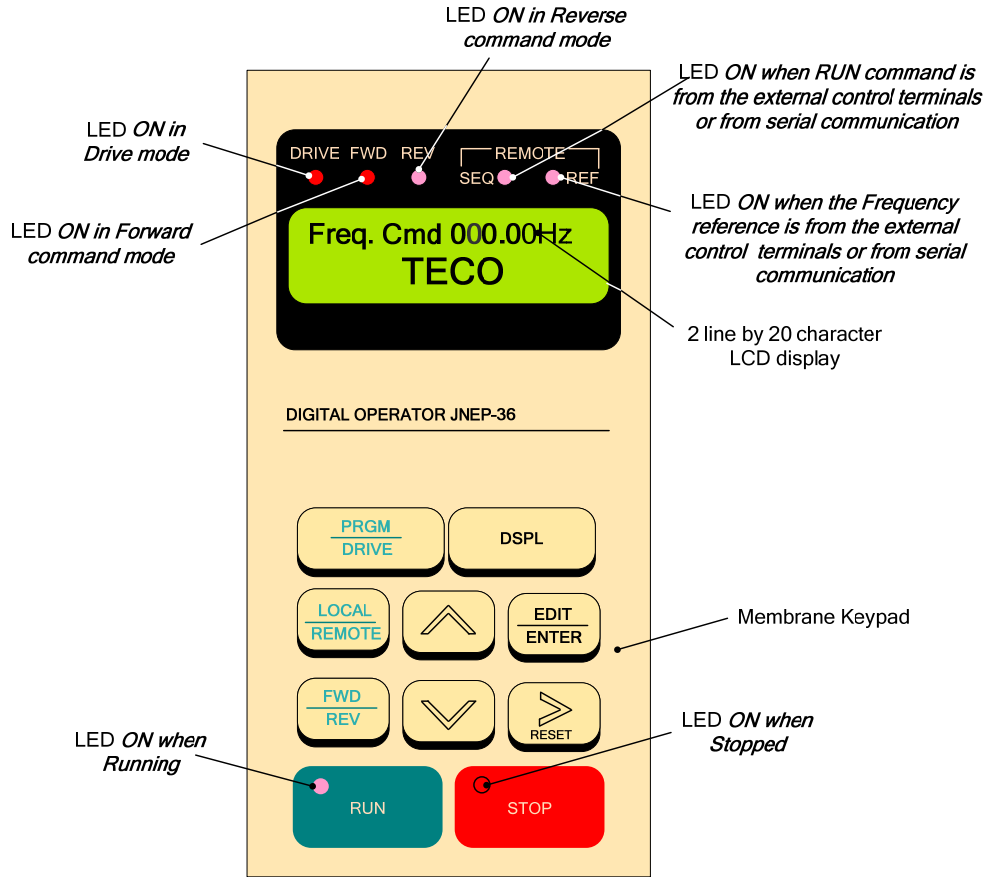



Fig. 8.2.1 JNEP-36 LCD Digital Operator

PRGM / Drive key-

There are two basic digital operator modes: The Drive mode and the PRGM mode. When the inverter is stopped, the Drive mode or PRGM mode can be selected by pressing the  key. In the Drive mode, the operation of the drive is enabled. In the PRGM mode the parameters can be set but drive operation is disabled.

Remote/Local function:

- Local mode – The RUN command is input from the LCD Digital Operator (SEQ LED off)
 - The Frequency command is input from the LCD Digital Operator (REF LED off)
- Remote mode – The RUN command is input from the control circuit terminals (when Sn-04=1) or the RS-485 comm. port (when Sn-04=2) (SEQ LED on)
 - The Frequency command is input from the control circuit terminals (when Sn-05=1) or the RS-485 comm. port (when Sn-05=2) (REF LED on)

LOCAL / REMOTE key-











The  key is used as Local/Remote key. It can be set as JOG key when parameter P1-03 = 1.

Cont.

8.3 Digital Operator Key Functions

The following Table 8.3.1 describes the functions of the keys.

Table 8.3.1 Key Functions

KEY	NAME	DESCRIPTION
	PRGM/DRIVE	Switches over between the program mode (PRGM) and the drive mode (DRIVE).
	DSPL	Displays the operating status.
	LOCAL /REMOTE (JOG)	When parameter P1-03 = 0, it toggles the Local/Remote Function. When parameter P1-03 = 1, it act as the Jog key when in the DRIVE mode.
	FWD / REV	Sets the direction of rotation the Digital Operator.
	Digit Select & RESET	Selects a particular digit to be changed when setting values on the LCD display. (Used with the Increment and Decrements keys). It also acts as the RESET key when a fault has occurred.
	Increment	Selects menu items, groups, functions, parameters, and increments the value of a selected digit.
	Decrement	Selects menu items, groups, functions, parameters, and decrements the value of a selected digit.
	EDIT / ENTER	(EDIT) - select menu items, groups, functions and sets values. (ENTER) - saves a particular operation or value to memory.
	RUN	Starts inverter operation in the (DRIVE) mode when the using the Digital Operator. (The LED will come ON.)
	STOP	Stops inverter operation from the Digital Operator. The STOP key can be enabled or disabled by the setting of parameter Sn-07 when operating from the control circuit terminals.

Caution To avoid keypad damage, do not operate it with a screwdriver or any sharp or hard tool.

8.4 Run / Stop Status Indicators

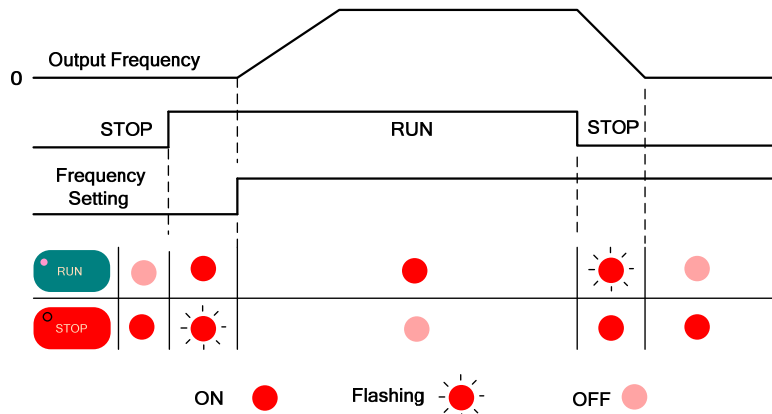

Fig. 8.4.1 Run / Stop Status Indicators

8.5 Display Menu for DRIVE and PRGM Modes

The following Fig. 8.5.1 shows the menu structure for the program mode (PRGM) and the drive mode (DRIVE). Refer to the parameter section 9.0 for an in depth explanation for the various parameter groups shown.

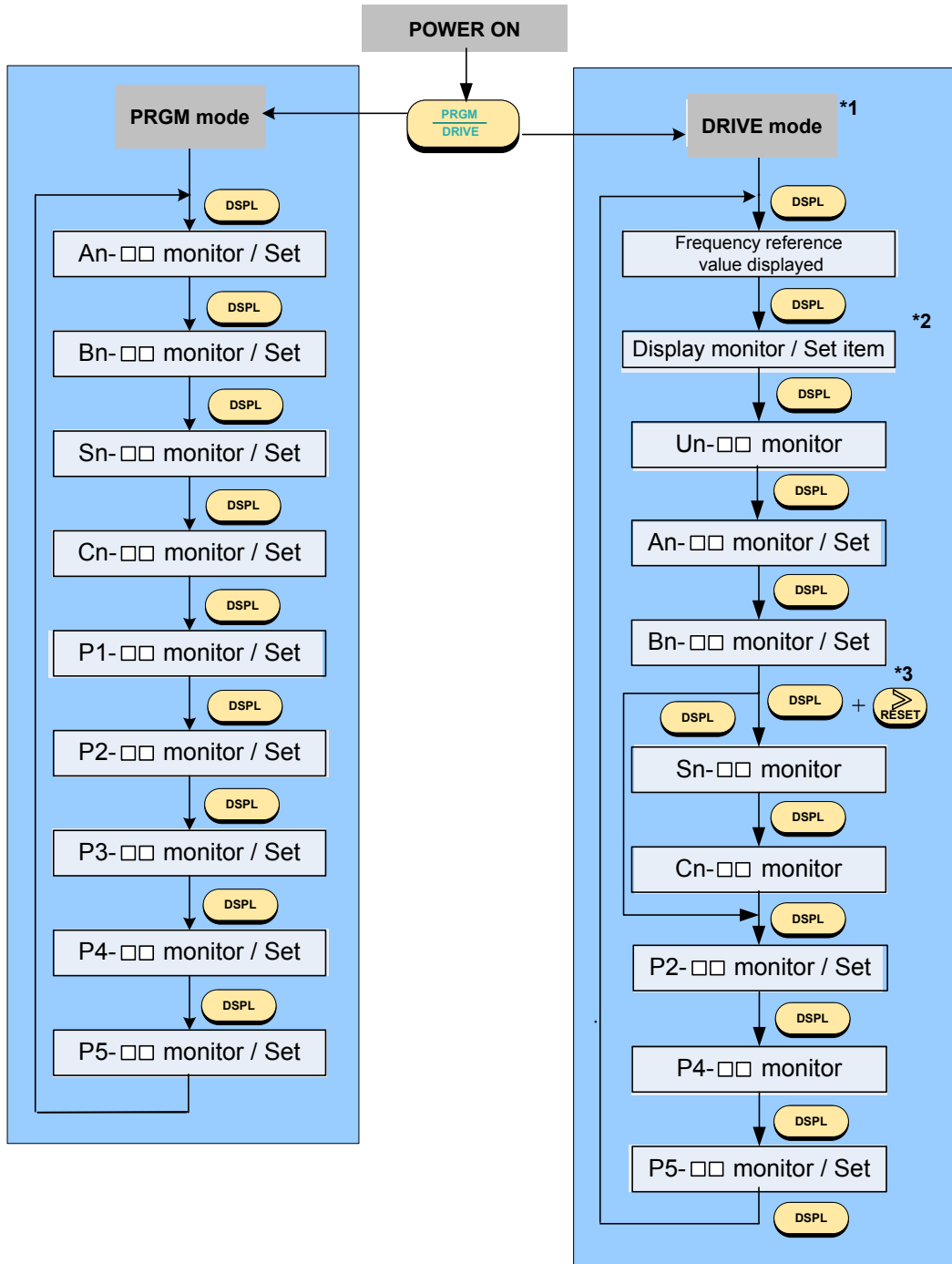

Fig. 8.5.1 DRIVE and PRGM Display Menus

- *1 When powered up, the inverter immediately enters the DRIVE mode. Pressing the PRGM / DRIVE key will switch to the PRGM mode. If a fault occurs, press the PRGM / DRIVE key and enter the DRIVE mode and then the DSPL key to access the corresponding Un-□□ fault contents. Once the fault is cleared, press the RESET key.
- *2 The monitored items will be displayed according to the settings of parameters Bn-12 and Bn-13.
- *3 When in the DRIVE mode, press the DSPL key and the RESET key; the set values of parameters Sn- □□ and Cn-□□ will be displayed for monitoring only and can not be changed or set here.

8.6 Some Examples of keypad navigation

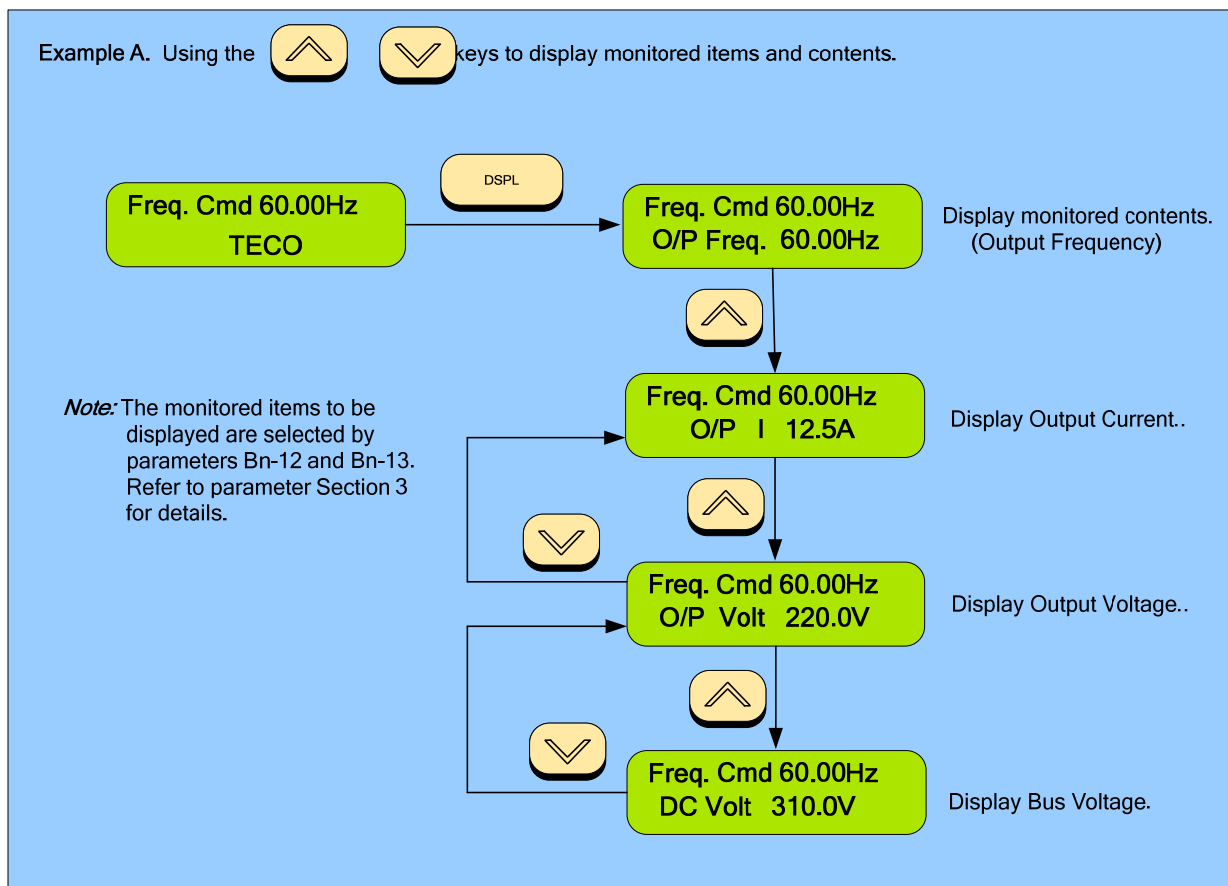

Fig. 8.6.1 Using the UP / DWN Keys

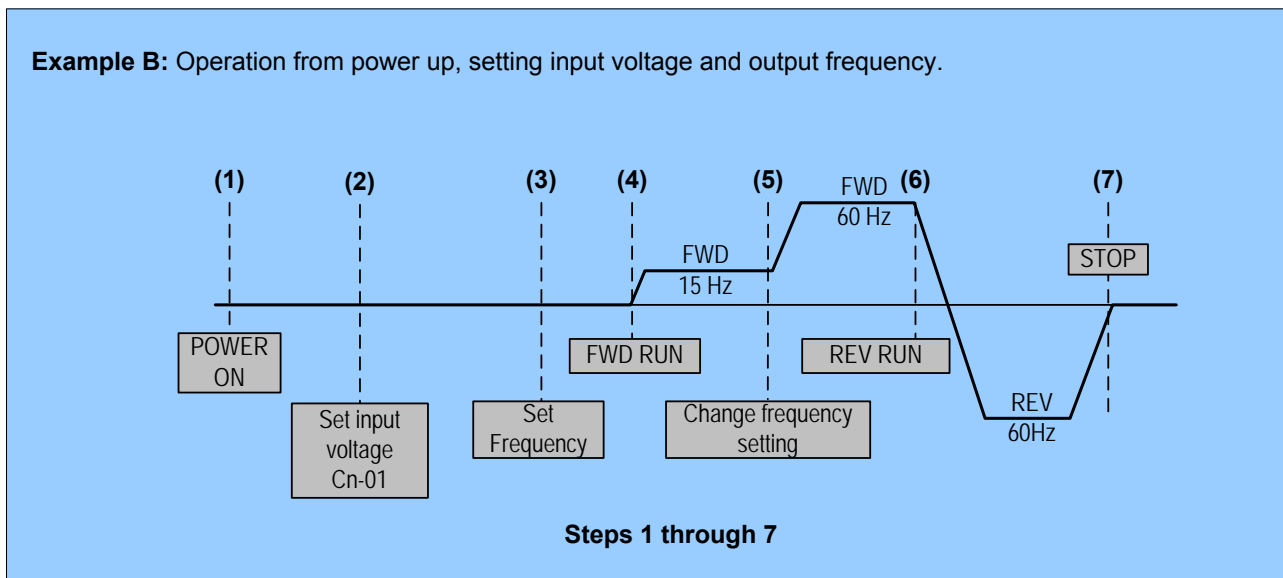

Fig. 8.6.2 Setting the Input Voltage and Output Frequency

The following Fig. 8.6.3 shows the keypad navigation for Example B following Steps 1 to 7. It will acquaint the user with the process of changing other parameters and settings.

Cont.

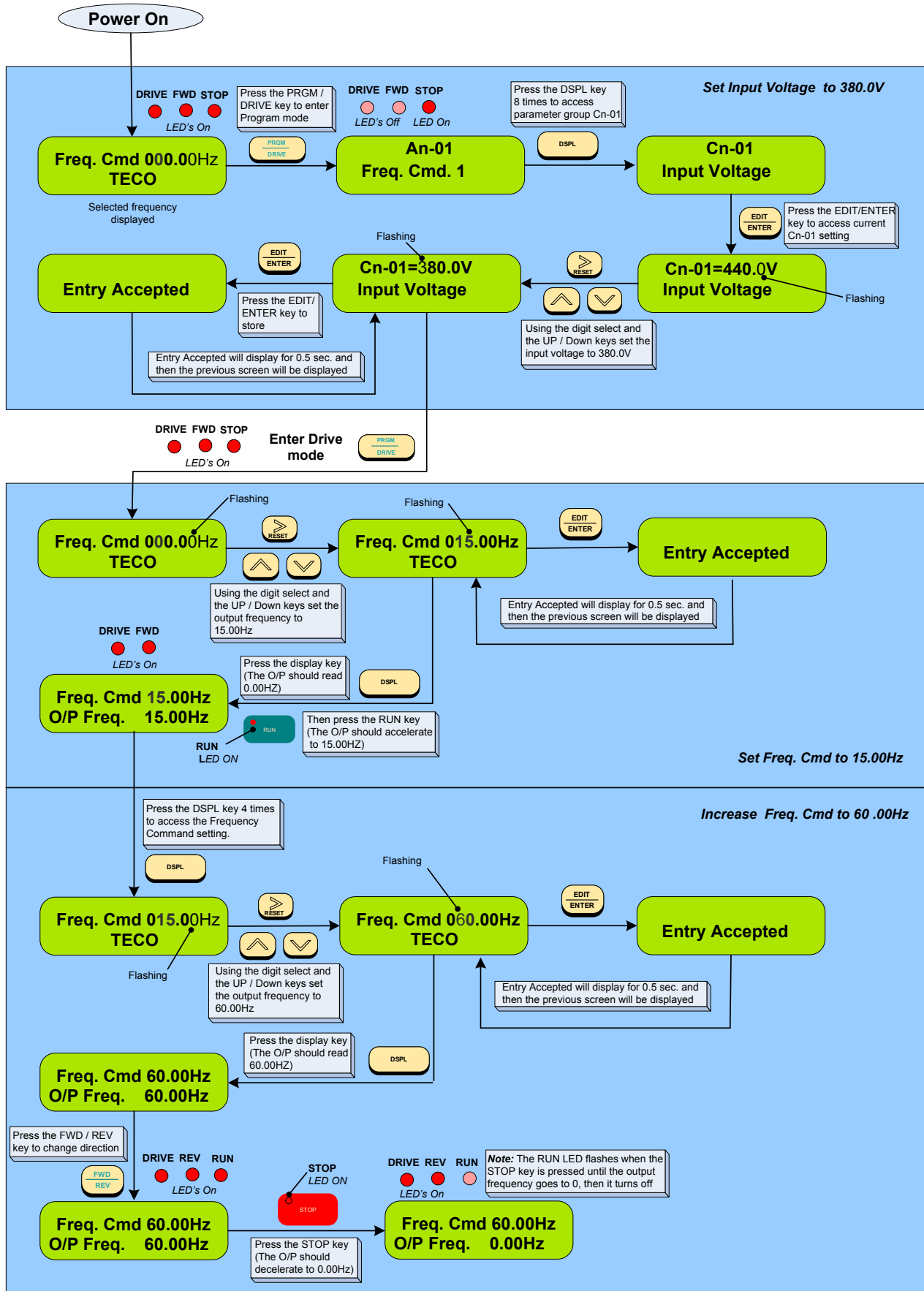

Fig. 8.6.3 PRGM and DRIVE Keypad Navigation

9.0 Parameter Summary and Explanation

This section describes the various parameter groups that are available in the MA7200 PLUS. Sub-section 9.1 gives a summary of the parameters while Sub-section 9.2 gives a more detailed explanation.

9.1 Parameter Summary Tables

Table 9.1.1 An-□□ Frequency Command (Multi-speed operation)

(In the drive mode these parameters can be monitored and their values set.)

Parameter No.	Name	LCD Display (English)	Setting Range	Setting Unit	Factory Setting	Ref.
An-01	Frequency Command 1	An-01= 000.00Hz Freq. Cmd. 1	0.00 - 400.00Hz	0.01Hz	0.00Hz	Sec. 9.2.3
An-02	Frequency Command 2	An-02= 000.00Hz Freq. Cmd. 2				
An-03	Frequency Command 3	An-03= 000.00Hz Freq. Cmd. 3				
An-04	Frequency Command 4	An-04= 000.00Hz Freq. Cmd. 4				
An-05	Frequency Command 5	An-05= 000.00Hz Freq. Cmd. 5				
An-06	Frequency Command 6	An-06= 000.00Hz Freq. Cmd. 6				
An-07	Frequency Command 7	An-07= 000.00Hz Freq. Cmd. 7				
An-08	Frequency Command 8	An-08= 000.00Hz Freq. Cmd. 8				
An-09	Frequency Command 9	An-09= 000.00Hz Freq. Cmd. 9				
An-10	Frequency Command 10	An-10= 000.00Hz Freq. Cmd. 10				
An-11	Frequency Command 11	An-11= 000.00Hz Freq. Cmd. 11				
An-12	Frequency Command 12	An-12= 000.00Hz Freq. Cmd. 12				
An-13	Frequency Command 13	An-13= 000.00Hz Freq. Cmd. 13				
An-14	Frequency Command 14	An-14= 000.00Hz Freq. Cmd. 14				
An-15	Frequency Command 15	An-15= 000.00Hz Freq. Cmd. 15				
An-16	Frequency Command 16	An-16= 000.00Hz Freq. Cmd. 16				
An-17	Jog Frequency Command	An-17= 000.00Hz Jog Freq. Cmd.			6.00Hz	

- 1 - The values assigned to parameters An-01 to An-02 are selected by the multi-function input terminals 5-8 and set by parameters Sn-25 to Sn-28. (See Table 9.3.2.4)
- 2- The units to be displayed can be changed through the parameter Cn-28 and P1-01.

Table 9.1.2 Bn-□□ Parameter Groups that can be Changed During Running

(In the drive mode the parameters can be monitored and their values set.)

Function	Parameter No.	Name	LCD display (English)	Setting range	Setting Unit	Factory Setting	Ref.
Acc/Dec time	Bn-01	Acceleration Time 1	Bn-01= 0010.0s Acc. Time 1	0.0 - 6000.0s	0.1s	30.0s	Sec. 9.2.1 & App-1
	Bn-02	Deceleration Time 1	Bn-02= 0010.0s Dec. Time 1				
	Bn-03	Acceleration Time 2	Bn-03= 0010.0s Acc. Time 2				
	Bn-04	Deceleration Time 2	Bn-04= 0010.0s Dec. Time 2				
Analog Frequency	Bn-05	Analog Frequency Cmd. Gain (Voltage)	Bn-05= 0100.0% Voltage Cmd. Gain	0.0 -1000.0%	0.10%	100.00%	Sec. 9.2.1
	Bn-06	Analog Frequency Cmd. Bias (Voltage)	Bn-06= 000.0% Voltage Cmd. Bias	-100.0% -100.0%		0.00%	
	Bn-07	Analog Frequency Cmd Gain. (Current)	Bn-07= 0100.0% Current Cmd. Gain	0.0 - 1000.0%		100.00%	
	Bn-08	Analog Frequency Cmd Bias (Current)	Bn-08= 000.0% Current Cmd. Bias	-100.0% - 100.0%		0.00%	
Multi-Function Analog Input	Bn-09	Multi-Function Analog Input Gain	Bn-09= 0100.0% Multi_Fun. ~Gain	0.0 - 1000.0%	0.1	100.00%	
	Bn-10	Multi-Function Analog Input Bias	Bn-10= 000.0% Multi_Fun. ~Bias	-100.0% - 100.0%		0.00%	
Torque Boost	Bn-11	Auto Torque Boost Gain	Bn-11= 0.5 Auto_Boost Gain	0.0 - 2.0	0.1	0.5	
Monitor	Bn-12	Monitor 1	Bn-12= 01 Display: Freq.Cmd.	1 - 30	1	1	
	Bn-13	Monitor 2	Bn-13= 19 Display: PID FBK.			19	
Multi-Function Analog Output	Bn-14	Multi-Function Analog Output AO1 Gain	Bn-14= 1.00 -Output AO1 Gain	0.01- 2.55	0.01	1	
	Bn-15	Multi-Function Analog Output AO2 Gain	Bn-15= 1.00 -Output AO2 Gain				
PID Control	Bn-16	PID Detection Gain	Bn-16= 01.00 PID Cmd. Gain	0.01 - 10.00	0.01	1	Sec. 9.2.1 & APP-1
	Bn-17	PID Proportional Gain	Bn-17= 01.00 PID P_gain				
	Bn-18	PID integral time	Bn-18= 10.00s PID I_Time	0.00 -100.00s	0.01s	10.00s	
	Bn-19	PID Differential Time	Bn-19= 0.00s PID D_Time			0 -1.00s	
	Bn-20	PID Bias	Bn-20= 0% PID Bias	0 -109%	1%	0%	

Cont.

Function	Parameter No.	Name	LCD display (English)	Setting range	Setting Unit	Factory Setting	Ref. Page
Auto_Run Time Function	Bn-21	1st_Step Time Under Auto_Run Mode	Bn-21= 0000.0s Time 1	0.0 - 6000.0s	0.1s	0.0s	Sec. 9.2.1
	Bn-22	2nd_Step Time Under Auto_Run Mode	Bn-22= 0000.0s Time 2				
	Bn-23	3rd_Step Time Under Auto_Run Mode	Bn-23= 0000.0s Time 3				
	Bn-24	4th_Step Time Under Auto_Run Mode	Bn-24= 0000.0s Time 4				
	Bn-25	5th_Step Time Under Auto_Run Mode	Bn-25= 0000.0s Time 5				
	Bn-26	6th_Step Time Under Auto_Run Mode	Bn-26= 0000.0s Time 6				
	Bn-27	7th_Step Time Under Auto_Run Mode	Bn-27= 0000.0s Time 7				
	Bn-28	8th_Step Time Under Auto_Run Mode	Bn-28= 0000.0s Time 8				
	Bn-29	9th_Step Time Under Auto_Run Mode	Bn-29= 0000.0s Time 9				
	Bn-30	10th_Step Time Under Auto_Run Mode	Bn-30= 0000.0s Time 10				
	Bn-31	11th_Step Time Under Auto_Run Mode	Bn-31= 0000.0s Time 11				
	Bn-32	12th_Step Time Under Auto_Run Mode	Bn-32= 0000.0s Time 12				
	Bn-33	13th_Step Time Under Auto_Run Mode	Bn-33= 0000.0s Time 13				
	Bn-34	14th_Step Time Under Auto_Run Mode	Bn-34= 0000.0s Time 14				
	Bn-35	15th_Step Time Under Auto_Run Mode	Bn-35= 0000.0s Time 15				
	Bn-36	16th_Step Time Under Auto_Run Mode	Bn-36= 0000.0s Time 16				
Timer Function	Bn-37	Timer Function On_Delay Time	Bn-37= 0000.0s ON_delay Setting	50 - 150%	1%	100%	Sec. 9.2.1
	Bn-38	Timer Function Off_Delay Time	Bn-38= 0000.0s OFF_delay Setting				
Energy Saving	Bn-39	Energy_Saving Gain	Bn-39= 100% Eg.Saving Gain	00 - 30	1	0	Sec. 9.2.1
Monitor	Bn-40	Monitor 3	Bn-40=00 Display : Set_Freq.				

Cont.

Function	Parameter No.	Name	LCD display (English)	Setting range	Setting Unit	Factory Setting	Ref. Page
Pulse Input	Bn-41	Pulse Input Upper Limit	Bn-41=1440 Hz Pulse_Mul_Up_Bound	1440 - 32000	1 Hz	1440	Sec. 9.2.1
	Bn-42	Pulse Input Gain	Bn-41=100.0 % Pulse_Mul_Gain	0.0 - 1000.0	0.10%	100	
	Bn-43	Pulse Input Bias	Bn-41=000.0 % Pulse_Mul_Bias	-100.0 - 100.0	0.1Hz	0	
	Bn-44	Pulse Input Delay Time	Bn-41=0.10 s Pulse_Mul_Filter	0.00 - 2.00	0.01s	0.1	
-	Bn-45 ^{*1}	Not Used	-	-	-	-	-
	Bn-46 ^{*1}	Not Used	-	-	-	-	

*1 - These parameters are not available for 77.01 and later software versions.

Table 9.1.3 Cn- □ Control Parameters

Function	Parameter No.	Name	LCD display (English)	Setting range	Setting Unit	Factory Setting	Ref.
V/F Pattern Setting	Cn-01	Input Voltage	Cn-01= 230.0V Input Voltage	150.0 - 255.0V ^{*1}	0.1V	230.0V ^{*1}	Sec. 9.2.2
	Cn-02	Max. Output Frequency	Cn-02= 060.0Hz Max. O/P Freq.	50.0 - 400.0Hz	0.1Hz	60.0Hz	
	Cn-03	Max. Output Voltage	Cn-03= 230.0Hz Max. Voltage	0.1 - 255.0V ^{*1}	0.1V	230.0V ^{*1}	
	Cn-04	Max. Voltage Frequency	Cn-04= 060.0Hz Max. Volt Frequency	0.1 - 400.0Hz	0.1Hz	60.0Hz	
	Cn-05	Middle Output Frequency	Cn-05= 003.0Hz Middle O/P Freq.			3.0Hz	
	Cn-06	Voltage At Middle Output Frequency	Cn-06= 014.9V Middle Voltage	0.1 - 255.0V ^{*1}	0.1V	15.5V ^{*1}	
	Cn-07	Min Output Frequency	Cn-07= 001.5Hz Min O/P Freq.	0.1 - 400.0Hz	0.1Hz	1.5Hz	
	Cn-08	Voltage At Min. Output Frequency	Cn-08= 007.9V Min. Voltage	0.1 - 255.0V ^{*1}	0.1V	8.2V ^{*1}	
Motor Parameter	Cn-09	Motor Rated Current	Cn-09= 0003.3A Motor Rated I	*2	0.1A	3.3A ^{*3}	
	Cn-10	No Load Current Of Motor	Cn-10= 30% Motor No-Load I	0 - 99%	1%	30%	
	Cn-11	Rated Slip Of Motor	Cn-11= 0.0% Motor Rated Slip		0.10%	0.00%	
	Cn-12	Line-To-Line Resistance Of Motor	Cn-12= 05.732Ω Motor Line R	0 - 65.535Ω	0.001Ω	5.732 ^{*3}	
	Cn-13	Torque Compensation Of Core Loss	Cn-13= 0064W Core Loss	0 - 65535W	1W	64 ^{*3}	

Cont.

Function	Parameter No.	Name	LCD display (English)	Setting range	Setting Unit	Factory Setting	Ref.
DC Braking Function	Cn-14	DC Injection Braking Starting Frequency	Cn-14= 01.5Hz C Braking Start F	0.1 - 10.0 Hz	0.1Hz	1.5Hz	Sec. 9.2.2
	Cn-15	DC Braking Current	Cn-15= 050% DC Braking Current	0 - 100%	1%	50%	
	Cn-16	DC Injection Braking Time At Stop	Cn-16= 00.5s DC Braking Stop Time	0.0 - 25.5s	0.1s	0.5s	
	Cn-17	DC Injection Braking Time At Start	Cn-17= 00.0s DC Braking Start Time			0.0s	
Frequency Limit	Cn-18	Frequency Command Upper Bound	Cn-18= 100% Freq.Cmd. Up Bound	0 - 109%	1%	100%	
	Cn-19	Frequency Command Lower Bound	Cn-19= 000% Freq. Cmd. Low Bound			0%	
Frequency Jump	Cn-20	Frequency Jump Point 1	Cn-20= 000.0Hz Freq. Jump 1	0.0 - 400.0Hz	0.1Hz	0.0Hz	
	Cn-21	Frequency Jump Point 2	Cn-21= 000.0Hz Freq. Jump 2				
	Cn-22	Frequency Jump Point 3	Cn-22= 000.0Hz Freq. Jump 3				
	Cn-23	Jump Frequency Width	Cn-23= 01.0Hz Freq. Jump Width	0.0 - 25.5Hz	0.1Hz	1.0Hz	
	Cn-24	Number of Auto Restart Attempt	Cn-24= 00 Retry Times	0 - 10	1	0	
	Cn-25	Stall Prevention During Acceleration	Cn-25= 170% Acc. Stall	30 - 200%	1%	170%	
	Cn-26	Stall Prevention During Running	Cn-26= 160% Run Stall			160%	
	Cn-27	Communication Fault Detection Time	Cn-27=01.0s Comm. Flt Det. Time	0.1 - 25.5s	0.1s	1s	
	Cn-28	LCD Digital Operator Display Unit	Cn-28= 00000 Operator Disp. Unit	0 -39999	1	0	
	Cn-29	Freq. Agree Detection Level During Accel.	Cn-29= 000.0Hz Acc. Freq. Det.Level	0.0 - 400.0Hz	0.1Hz	0.0Hz	
	Cn-30	Freq. Agree Detection Level During Decel.	Cn-30= 000.0Hz Dec. Freq. Det. Level				
	Cn-31	Frequency Agree Detection Width	Cn-31= 02.0Hz F Agree Det. Width	0.1 - 25.5Hz	0.1Hz	2.0Hz	
	Cn-32	Excess Load Detection Level	Cn-32= 160% Excess Load Level	0 - 200%	1%	160%	
	Cn-33	Excess Load Detection Time	Cn-33= 00.1s Excess Load Det.Time	0.0 - 25.5s	0.1s	0.1s	
Cn-34	Carrier frequency setting	Cn-34= 6 Carry_Freq Setting	1- 6	1	6		

Cont.

Function	Parameter No.	Name	LCD display (English)	Setting range	Setting Unit	Factory Setting	Ref.
Speed Search Control	Cn-35	Speed Search Detection Level	Cn-35= 150% Sp-Search Level	0 - 200%	1%	150%	Sec. 9.2.2 & 9.2.3
	Cn-36	Speed Search Time	Cn-36= 02.0s Sp-Search Time	0.1 - 25.5s	0.1s	2.0s	
	Cn-37	Min. Baseblock Time	Cn-37= 0.5s Min. B.B. Time	0.5 - 5.0s		0.5s	
	Cn-38	V/F Curve in Speed Search	Cn-38= 80% Sp-search V/F Gain	10 - 100%	1%	80%	
Low Voltage Detection	Cn-39	Low Voltage Alarm Detection Level	Cn-39= 200V Low Volt. Det. Level	150 - 210V ^{*1}	1V	200V ^{*1}	
Slip Comp.	Cn-40	Slip Compensation Primary Delay Time	Cn-40= 02.0s Slip Filter	0.0 - 25.5s	0.1s	2.0s	
S-curve time	Cn-41	S-curve Characteristic Time at Accel. Start	Cn-41= 0.0s S1 Curve Time	0.0 - 1.0s	0.1s	0.0s	Sec. 9.2.2
	Cn-42	S-curve Characteristic Time at Accel. End	Cn-42= 0.0s S2 Curve Time				
	Cn-43	S-curve Characteristic Time at Decel. start	Cn-43= 0.0s S3 Curve Time				
	Cn-44	S-curve Characteristic Time at Decel. end	Cn-44= 0.0s S4 Curve Time				
Speed feedback control	Cn-45	PG Parameter	Cn-45= 0000.0 PG Parameter	0.0 - 3000.0P/R	0.1P/R	0.0P/R	Sec. 9.2.2 & Fig. 4.2.4
	Cn-46	Pole no. of Motor	Cn-46= 04P Motor Pole	2 - 32P	2P	4P	
	Cn-47	ASR Proportional Gain 1	Cn-47= 0.00 ASR Gain 1	0.00 - 2.55	0.01	0	Sec. 9.2.2
	Cn-48	ASR Integral Gain 1	Cn-48= 01.0s ASR Intgl. Time 1	0.1 - 10.0S	0.1s	1.0s	
	Cn-49	ASR Proportional Gain 2	Cn-49= 0.02 ASR Gain 2	0.00 - 2.55	0.01	0.02	
	Cn-50	ASR Integral Gain 2	Cn-50= 01.0s ASR Intgl. Time 2	0.1 - 10.0S	0.1s	1.0s	
	Cn-51	ASR Upper Bound	Cn-51= 05.0% ASR Up Bound	0.1 - 10.0%	0.10%	5.00%	
	Cn-52	ASR Lower Bound	Cn-52= 00.1% ASR Low Bound			0.10%	
	Cn-53	Excessive Speed Deviation Detection Level	Cn-53= 10% Sp.Deviat. Det.Level	1 - 50%	1%	10%	
	Cn-54	Overspeed Detection Level	Cn-54= 110% Over Sp.Det. Level	1 - 120%	1%	110%	
PID Control	Cn-55	PID Integral Upper Bound	Cn-55= 100% PID I-Upper	0 - 109%	1%	100%	Sec. 9.2.2 & App-1
	Cn-56	PID Primary Delay Time Constant	Cn-56= 0.0s PID Filter	0.0 - 2.5s	0.1s	0.0s	

Cont.

Function	Parameter No.	Name	LCD display (English)	Setting range	Setting Unit	Factory Setting	Ref.
Sensorless Vector Control	Cn-57	Motor Line-to-Line Resistance (R1)	Cn-57= 02.233Ω Mtr LINE_R	0.001 - 60.000Ω	0.001Ω	2.233Ω * ³	Sec. 9.2.2 & Appx A
	Cn-58	Motor Rotor Equivalent Resistance (R2)	Cn-58= 01.968Ω Mtr ROTOR_R			1.968Ω * ³	
	Cn-59	Motor Leakage Inductance (Ls)	Cn-59= 9.6mH Mtr LEAKAGE_X	0.01- 200.00mH	0.01mH	9.6mH * ³	
	Cn-60	Motor Mutual Inductance (Lm)	Cn-60= 149.7mH Mtr MUTUAL_X	0.1 - 6553.5mH	0.1mH	149.7mH * ³	
	Cn-61	Slip Compensation Gain	Cn-61= 1.00 SLIP GAIN	0.00 - 2.55	0.01	1.00	
-	Cn-62* ⁴	Not Used * ⁴	-	-	-	-	
	Cn-63* ⁴	Not Used * ⁴	-	-	-	-	
PID Target Limit	Cn-64	PID Target Upper Limit	Cn-64 = 100% PID Target U_Limit	0 -100%	1%	100%	APP-1
	Cn-65	PID Target Lower Limit	Cn-65 = 0% PID Target L_Limit			0%	

- *1 These values are for a 230V class inverter. Double the value for a 460V class inverter, and multiply the value by 2.875 for a 575v class inverter.
- *2 The setting range is 10% - 200% of the inverter rated current.
- *3 The factory setting values will vary based upon the inverter capacity selection (Sn-01) value. In this case, the setting is for 4-pole, 230V, 60Hz, 1Hp TECO standard induction motors.
- *4. These parameters are not available for 77.01 and later software versions.

Table 9.1.4 Sn- □□ System Parameters

Function	Parameter No.	Name	LCD display (English)	Description	Factory Setting	Ref.
Capacity Setting	Sn-01	Inverter Capacity Selection	Sn-01= 01 220V 1HP	Inverter capacity selection	*1	
V/F Curve	Sn-02	V/F Curve Selection	Sn-02= 01 V/F curve	0 -14: 15 fixed V/F curve pattern 15: Arbitrary V/F pattern selection	-	
Operator Status	Sn-03	Operator Display	Sn-03= 00 Setting Valid	0: An-□□, Bn-□□, Cn-□□, Sn-□□ setting & reading enabled 1: An-□□, setting & reading enabled Bn-□□, Cn-□□, Sn-□□ reading only 2 - 5: Reserved 6: C lear fault message 7: 2-wire initialization (230V/460V) 8: 3-wire initialization (230V/460V) 9: 2-wire initialization (200V/415V) 10: 3-wire initialization (200V/415V) 11: 2-wire initialization (200V/380V) 12: 3-wire initialization (200V/380V) 13 - 15: Reserved	-	Sec. 9.2.3

Cont.

Function	Parameter No.	Name	LCD display (English)	Description	Factory Setting	Ref.
Operation Control Mode Selection	Sn-04	Run Source Selection	Sn-04= 0 Run source Operator	Run source 0: Operator 1: Control terminal 2: RS-485 communication	0	Sec. 9.2.3
	Sn-05	Frequency Command Selection	Sn-05= 0 Ref. Cmd. Operator	Frequency Command 0: Operator 1: Control circuit terminal 2: RS-485 communication 3: Pulse input		
	Sn-06	Stopping Method Selection	Sn-06= 0 Dec. Stop	0: Deceleration to Stop 1: Coast to Stop 2: Total_range braking stop 3: Coast to Stop with Timer (Restart after time Bn-02)		
	Sn-07	Priority of Stopping	Sn-07= 0 Stop Key Valid	When operation command is from control terminal or RS-485 communication port 0: operator stop key effective 1: operator stop key not effective		
	Sn-08	Prohibition of REV Run	Sn-08= 0 Allow Reverse	0: reverse run enabled 1: reverse run disabled		
	Sn-09	Output Frequency Up/Down Function	Sn-09= 0 Inhibit UP/DOWN	0: Reference frequency is changed through pressing the "UP/DOWN" key, and then followed by pressing the "EDIT/ENTER" key. 1: Reference frequency will be changed immediately after the "UP/DOWN" is pressed.		
	Sn-10	Frequency Command Characteristics Selection	Sn-10= 0 Ref. Cmd. Fwd. Char.	0: Reference command has forward characteristics (0-10V or 4-20mA / 0-100%) 1: Reference command has reverse characteristics (10-0V or 20-4mA / 0-100%)		
	Sn-11	Scanning Times at Input Terminal	Sn-11= 0 Scan Time 5 ms	0: Scan and confirm once per 5 ms 1: Continuously scan and confirm twice per 10 ms		

Cont.

Function	Parameter No.	Name	LCD display (English)	Description	Factory Setting	Ref.
Operation Control Mode Selection <i>Cont.</i>	Sn-12	Excess Load Detection Selection	Sn-12= 0 Detection Invalid	0: Excess Load detection function is not effective. 1: Excess Load is detected only at frequency agree. Continue operation after detection. 2: Excess Load is detected only at frequency agree. Stop operation after detection. 3: Excess Load is detected during running (Accel., Decel. included). Continue operation after detection. 4: Excess Load is detected during running (Accel., Decel included). Stop operation after detection.	0	Sec. 9.2.3 & 9.2.2
	Sn-13	Output Voltage Limit Selection	Sn-13= 0 V Limit Invalid	0: V/F output voltage is limited 1: V/F output voltage is not limited		
Protection Characteristic selection	Sn-14	Stall Prevention During Acc. Function Selection	Sn-14= 1 Acc. Stall Valid	0: invalid (Excessive torque may cause stall) 1: valid (Stop acceleration if current exceeds Cn-25 setting)	1	Sec. 9.2.3
	Sn-15	Stall Prevention During Dec. Function Selection	Sn-15= 1 Dec. Stall Valid	0: invalid (Installed with external brake unit) 1: valid (No external brake unit used)		
	Sn-16	Stall Prevention During Running Function Selection	Sn-16= 1 Run Stall Valid	0: invalid 1: valid –Deceleration time 1 for stall prevention during running (No external brake unit used) 2: valid –Deceleration time 2 for stall prevention during running (No external brake unit used)	1	
	Sn-17	Fault Retry Setting	Sn-17= 0 Retry No O/P	0: No output for fault retry. (The fault contact does not operate.) 1: Output fault retry. (The fault contact operates.)		
	Sn-18	Operation Selection At Power Loss	Sn-18= 0 PwrL_to_ON Stop O/P	0: Stop running 1: Continue to run		
	Sn-19	Zero Speed Braking Operation Selection	Sn-19= 0 Z_braking Invalid	When analog speed reference is 0 during running, the braking function is ON 0: invalid 1: valid	0	
	Sn-20	External Fault Contact ③ Contact Selection	Sn-20= 0 Term.3 NO_Cont.	0: A-contact (Normally open input) 1: B-contact (Normally close input)		

Cont.

Function	Parameter No.	Name	LCD display (English)	Description	Factory Setting	Ref.	
Protection Characteristic selection <i>Cont.</i>	Sn-21	External Fault Contact ③ Detection Selection	Sn-21= 0 All Time Ext. Fault	0: Detect all time 1: Detect only during operation	1	Sec. 9.2.3	
	Sn-22	External Fault Operation Selection	Sn-22 = 1 Ext. Fault Free run	0: Dec. to stop (Dec. time 1 Bn-02) 1: Coast (Free run) to stop 2: Dec. to stop (Dec. time 1 Bn-04) 3: Continue operating			
	Sn-23	Motor Overload Protection Selection	Sn-23= 1 Cold Start Over Load	Electronically motor overload protection selection. 0: Electronically motor overload protection invalid 1: Standard motor cold start overload protection characteristics 2: Standard motor hot start overload protection characteristics 3: Special motor cold start overload protection characteristics 4: Special motor hot start overload protection characteristics	1		
	Sn-24	Frequency Command Characteristics Selection at External Analog Input Terminal	Sn-24= 1 - Cmd. AIN	Frequency command characteristics selection at external analog input terminal. 0: Voltage signal 0-10V (VIN) 1: Current signal 4-20mA (AIN) 2: Addition of voltage signal 0-10V and current signal 4-20 mA (VIN+AIN) 3: Subtraction of current signal 4-20mA and voltage signal 0-10V (VIN-AIN)	0		
Multi-function Digital Input Selection	Sn-25	Multi-Function Input Terminal ⑤ Function Selection	Sn-25= 02 Multi-Fun. Command1	00-33	The factory setting is multi-function command 1	02	Sec. 9.2.3 & Figs' 2.1.2, 2.1.3 & 4.1.1
	Sn-26	Multi-Function Input Terminal ⑥ Function Selection	Sn-26= 03 Multi-Fun. Command 2	01-33	The factory setting is multi-function command 2	03	
	Sn-27	Multi-Function Input Terminal ⑦ Function Selection	Sn-27= 06 Jog Command	02-33	The factory setting is jog command	06	
	Sn-28	Multi-Function Input Terminal ⑧ Function Selection	Sn-28= 07 Acc. & Dec Switch	03-33	The factory setting is Acc. & Dec. Interrupt	07	
Multi-function Analog Input Selection	Sn-29	Multi-Function Analog Input (AUX) Function Selection	Sn-29= 00 Auxiliary Freq. Cmd.	00-19	Multi-function analog input terminal (AUX) as Auxiliary frequency command. (factory setting)	00	

Cont.

Function	Parameter No.	Name	LCD display (English)	Description	Factory Setting	Ref.
Multi-function Digital Output Selection	Sn-30	Multi-Function Output Terminal (RA-RB-RC) Function Selection	Sn-30= 13 Fault	00-28 Terminal (RA-RB-RC or R1A-R1B-R1C) as fault output (factory setting)	13	
	Sn-31	Multi-Function Output Terminal (DO1) Function Selection	Sn-31= 00 Running	00-28 Terminal (DO1-DOG) as digital output during running (factory setting).	00	
	Sn-32	Multi-Function Output Terminal (DO2) Function Selection	Sn-32= 01 Zero Speed	00-28 Terminal (DO2-DOG or R2A-R2C) as digital output at zero speed (factory setting)	01	
Multi-function Analog Output Selection	Sn-33	Multi-Function Analog Output (AO1) Function Selection	Sn-33= 00 Term. AO1 Freq. Cmd.	0: Freq. Cmd. (10V / MAX frequency command, Cn-02) 1: Output frequency (10V / MAX. output frequency) 2: Output current (10V / input rated current) 3: Output voltage (10V / input voltage, Cn-01) 4: DC voltage (10V / 400V or 10V / 800.V)	00	Sec. 9.2.3 & Figs' 2.1.2, 2.1.3 & 4.1.1
	Sn-34	Multi-Function Analog Output (AO2) Function Selection	Sn-34= 01 Term. AO2 O/P Freq.	5: External analog input command VIN (0-10V / 0-10V) 6: External analog input command AIN (0 – 10 V / 4 - 20mA) 7: Multi-function analog input (AUX) (10V / 10V) 8: PID control input 9: PID control output 1 10: PID control output 2 11: Communication Control 12 -14: HVAC Function	01	
	Sn-35	Pulse Output Multiplier Selection	Sn-35= 1 Pulse Mul. 6	When multi-function output terminal (DO1,DO2) is set as pulse signal output 0:1F 1: 6F 2:10F 3:12F 4: 36F	1	
RS-485 Communication Function	Sn-36	Inverter Address	Sn-36= 01 Inverter Address	Inverter address can be set as 1~31	01	Sec. 9.2.3 & Fig. 4.2.5
	Sn-37	RS-485 Comm. Baud Rate Setting	Sn-37= 1 Baud rate 2400	0: 1200 bps 1: 2400 bps 2: 4800 bps 3: 9600 bps 4: 19200 bps	3	
	Sn-38	RS-485 Comm. Transmission Parity Setting	Sn-38= 0 Reversed Bit	0: No parity 1: Even parity 2: Odd parity	0	
	Sn-39	RS-485 Comm. Fault Stop Selection	Sn-39= 0 1st. Dec. stop	0: Deceleration to stop (Bn-02) 1: Coast to stop 2: Deceleration to stop (Bn-04) 3: Continue to run	0	

Cont.

Function	Parameter No.	Name	LCD display (English)	Description	Factory Setting	Ref.
PG Speed Control	Sn-40	PG Speed Control Function	Sn-40= 0 PG Invalid	0: Without speed control 1: With speed control 2: With speed control but no integration control during Acc / Dec. 3: With speed control and integration control during Acc / Dec.	0	Sec. 9.2.3, 9.2.1 & Fig. 4.2.5
	Sn-41	Operation Selection At PG Open Circuit	Sn-41= 0 1st. Dec. Stop	0: Deceleration to stop (Bn-02) 1: Coast to stop 2: Deceleration to stop (Bn-04) 3: Continue to run	0	
	Sn-42	Operation Selection At PG Large Speed Deviation	Sn-42= 0 1st. Dec Stop	0: Deceleration to stop (Bn-02) 1: Coast to stop 2: Deceleration to stop (Bn-04) 3: Continue to run	0	
	Sn-43	Operation Selection At PG Overspeed Detection Deviation	Sn-43= 0 1st. Dec. Stop	0 : deceleration to stop (Bn-02) 1 : coast to stop 2 : deceleration to stop (Bn-04) 3 : continue to run	0	
Auto_Run Mode	Sn-44	Operation Mode Selection During Auto_Run	Sn-44= 0 Auto_Run Invalid	0: Auto_Run mode not effective 1: Auto_Run mode for one single cycle. (continue running from the unfinished step if restarting) 2: Auto_Run mode be performed periodically (continue running from the unfinished step if restarting) 3: Auto_Run mode for one single cycle, then hold the speed of final step to run. (continue running from the unfinished step if restarting) 4: Auto_Run mode for one single cycle. (Starting a new cycle if restarting) 5: Auto_Run mode be performed periodically (Starting a new cycle if restarting) 6: Auto_Run mode for one single cycle, then hold the speed of final step to run. (Starting a new cycle if restarting)		Sec. 9.2.3
	Sn-45	Auto_Run Mode Operation Selection1	Sn-45= 0 Auto_Run Stop	0: stop (Bn-02) 1: forward 2: reverse	0	
	Sn-46	Auto_Run Mode Operation Selection2	Sn-46= 0 Auto_Run Stop			

Cont.

Function	Parameter No.	Name	LCD display (English)	Description	Factory Setting	Ref.
Auto_Run Mode Cont.	Sn-47	Auto_Run Mode Operation Selection3	Sn-47= 0 Auto_Run Stop	0: stop (Bn-02) 1: forward 2: reverse	0	Sec. 9.2.3, 9.1.1 & 9.2.2
	Sn-48	Auto_Run Mode Operation Selection4	Sn-48= 0 Auto_Run Stop			
	Sn-49	Auto_Run Mode Operation Selection5	Sn-49= 0 Auto_Run Stop			
	Sn-50	Auto_Run Mode Operation Selection6	Sn-50= 0 Auto_Run Stop			
	Sn-51	Auto_Run Mode Operation Selection7	Sn-51= 0 Auto_Run Stop			
	Sn-52	Auto_Run Mode Operation Selection8	Sn-52= 0 Auto_Run Stop			
	Sn-53	Auto_Run Mode Operation Selection9	Sn-53= 0 Auto_Run Stop			
	Sn-54	Auto_Run Mode Operation Selection10	Sn-54= 0 Auto_Run Stop			
	Sn-55	Auto_Run Mode Operation Selection11	Sn-55= 0 Auto_Run Stop			
	Sn-56	Auto_Run Mode Operation Selection12	Sn-56= 0 Auto_Run Stop			
	Sn-57	Auto_Run Mode Operation Selection13	Sn-57= 0 Auto_Run Stop			
	Sn-58	Auto_Run Mode Operation Selection14	Sn-58= 0 Auto_Run Stop			
	Sn-59	Auto_Run Mode Operation Selection15	Sn-59= 0 Auto_Run Stop			
	Sn-60	Auto_Run Mode Operation Selection16	Sn-60= 0 Auto_Run Stop			
	Sn-61	Applied Torque Mode	Sn-61= 0 Const. Tq. Load	0: Constant torque 1: Variable (quadratic) torque	0	Sec. 9.2.3
	Sn-62 ^{*2}	Not Used	Sn-62= 0 Reserved	–	–	

Cont.

Function	Parameter No.	Name	LCD display (English)	Description	Factory Setting	Ref.
	Sn-63	Parameter Copy	Sn-63=0 Not Load	0: Not loaded (copied) 1: Upload from digital operator to inverter 2: Download from inverter to digital operator 3: Test the EEPROM of digital operator 4: Test the EEPROM of inverter	0	Sec. 9.2.3
	Sn-64	PID Function	Sn-64=0 PID Invalid	0: PID invalid 1 - 8: PID valid	0	Sec. 9.2.3 & APP-1
	Sn-65 *2	Not Used	Sn-65=0 Reserved	-	-	-
Sensorless Vector Control	Sn-66	Motor Parameters Autotuning Selection	Sn-66=0 AUTO TUNE SEL	0: Autotuning invalid 1: Autotuning valid	0	Sec. 9.2.3 & Appnx A
	Sn-67	Control Mode Selection	Sn-67=0 CNTRL MODE SEL	0: V/F control mode (include V/F control with pulse generator feedback) 1: Sensorless Vector Control Mode		Sec. 9.2.3, 9.2.2 & Appx A
	Sn-68	Control selection	Sn-68=0000 Control selection	___ 1: Output phase loss protection function valid ___ 0: Output phase loss protection function invalid __ 1 _: Reserved __ 0 _: Reserved *2 _ 1 __: ±10V analog voltage input function is valid *2 _ 0 __: ±10V analog voltage input function is invalid 1 ___: Frequency Up/Down hold function valid 0 ___: Frequency Up/Down hold function invalid * 1-2HP inverter does not support Input of ±10V analog voltage.	0	Sec. 9.2.3
	Sn-69	Not Used	-	This parameter is not available for version 77.01 and later.	0	
	Sn-70	Not Used	-	This parameter is not available for version 77.01 and later.	0	

*1. The default setting will depend upon the inverter capacity.

*2. These parameters are not available for version 77.01 and later.

Table 9.1.4 P□- □□ Application Parameters

(The P parameters were developed mainly for fan and pump applications. “App-2 Fan and PUMP Application Note” covers this subject and details the use of these and other parameters.)

Function	Parameter No.	Name	LCD display (English)	Setting range	Factory Setting	Ref.
Engineering Unit	P1-01	Engineering Unit Selection	P1-01 Engineering Unit	00 - 25	00 (Set by Cn-28)	Sec. 9.2.4 & APP-1, APP-2
Maximum Feedback	P1-02	Maximum Feedback Selection	P1-02 Feedback Maximum	10 - 9999 (Engineering Units set by P1-01)	0	
Local / Remote	P1-03	Local / Remote Key	P1-03 Local / Remote Key	0: Enabled 1: Disabled	0	
Sleep Function	P1-04	Sleep Function Enable / Disable	P1-04 PID Sleep Function	0: PID Sleep Invalid 1: PID Sleep Valid	0	
	P1-05	PID Wakeup Direction	P1-05 PID Wakeup Direction	0: Feedback above 1: Feedback below	1	
External PID Control	P1-06	External PID Function	P1-06 Ext. PID Function	0: Ext. PID Invalid 1: Ext. PID, AO1 output 2: Ext. PID, AO2 output	0	Sec. 9.2.4 & APP-1
	P1-07	External PID Set Point Source	P1-07 Ext. PID Set Source	0: Set Point Parameter 1: Terminal VIN 2: Terminal AIN 3: Terminal AUX 4: Set Point RS-485	0	
	P1-08	External PID Set Feedback Source	P1-08 Ext. PID Fbk. Source	1: Feedback Term. VIN 2: Feedback Term. AIN 3: Feedback Term. AUX	3	
	P1-09	External PID Set Point Integral Limit	P1-09 Ext. PID I Limit	1 - 100%	100%	
	P1-10	External PID Filter Time	P1-10 Ext. PID Filter	0.0 - 2.5s	0.0s	
Sleep Function	P2-01	Sleep Start Level	P2-01 Sleep Start Level	000.00 - 100.00%	000.00%	Sec. 9.2.4 & APP-2
	P2-02	Sleep Start Delay	P2-02 Sleep Start Delay	000.1 - 600.0 s	0001.0 s	
	P2-03	Sleep Wakeup Level	P2-03 Sleep Wakeup Level	000.00 - 099.99%	000.00%	
	P2-04	Sleep Wakeup Delay	P2-04 Sleep Wakeup Delay	000.1 - 600.0 s	001.0 s	
External PID Control	P2-05	External PID Set Point Range	P2-05 Ext. PID Set Point	0.0 - 100.0%	0.0%	Sec. 9.2.4 & APP-1
	P2-06	External PID Set Point Feedback Gain	P2-06 Ext. PID Fbk. Gain	0.01 - 10.00	1.00	
	P2-07	External PID Set Point Proportional Gain	P2-07 Ext. PID P Gain	0.01 - 10.00	1.00	

Cont.

Function	Parameter No.	Name	LCD display (English)	Setting range	Factory Setting	Ref.
External PID Control	P2-08	External PID Set Point Integral Gain	P2-08 Ext. PID I Time	0.00 - 100.00 s	10.00 s	Sec. 9.2.4 & APP-1
	P2-09	External PID Set Point Derivative Gain	P2-09 Ext. PID D Time	0.00 - 1.00s	1.00 s	
	P2-10	External PID Bias	P2-10 Ext. PID Bias	-100 -100%	0%	
Load Loss	P3-01	Load Loss Detection Level	P3-01 Load Loss Det. Level	000 - 200%	030%	Sec. 9.2.4 & APP-2
	P3-02	Load Loss Detection Time	P3-02 Load Loss Det. Time	00.0 - 25.5s	05.0s	
	P3-04	Load Loss Action	P3-03 Load Loss Action	0: None 1: Load Loss Alarm 2: Load Loss Fault	0	
Feedback	P3-04		P3-04 Over Feedback Level	* 000.00 - 099.99%	000.00%	
	P3-05		P3-05 Over Fbk. Delay Time	0000.0 - 6000.0s	0003.0s	
	P3-06	Over Feedback Action	P3-06 Over Fbk. Action	0: None 1: Over Feedback Alarm 2: Over Feedback Fault	0	
	P3-07	Low Feedback Level	P3-07 Low Feedback Level	* 000.00 - 099.99%	000.00%	
	P3-08	Low Feedback Delay Time	P3-08 Low Fbk. Delay Time	0000.0 - 6000.0s	0003.0s	
	P3-09	Low Feedback Action	P3-09 Low Fbk. Action	0: None 1: Low Feedback Alarm 2: Low Feedback Fault	0	
Suction	P3-10	Low Suction Detection	P3-10 Low Suction Detect	1: PID Error 2: Current 3: Error and Current	1	
	P3-11	Low Suction Detection Time	P3-11 Low Suc. Det. Time	000 - 300s	100s	
	P3-12	Low Suction PID Error	P3-12 Low Suc. PID Error	01 - 30%	10%	
	P3-13	Low Suction Current	P3-13 Low Suction Current	000.1 - 200.0A	001.0 A	
	P3-14	Low Suction Action	P3-14 Low Suction Action	0: None 1: Low Suction Alarm 2: Low Suction Fault 3: Fault and Restart	1	
Restart	P3-15	Restart Delay	P3-15 Restart Delay	0005 - 6000s	0300s	
	P3-16	Restart Selection	P3-16 Restart Selection	0: With Speed Search 1: W/O Speed Search	1	

* The engineering units and range are set by parameter P1-01

Cont.

Function	Parameter No.	Name	LCD display (English)	Setting range	Factory Setting	Ref.
Flow Meter	P4-01	Flow Meter Function	P4-01 Flow Meter Function	0: None 1: Aux Input 2: Pulse Train Input	0	Sec. 9.2.4 & APP-1
	P4-02	Maximum Flow for 10V AUX	P4-02 Max Flow for 10V AUX	00000 – 50000 GPM	01000 GPM	
	P4-03	No Flow for AUX	P4-03 No Flow point for AUX	0.0 - 5.0V	0.0V	
	P4-04	Input Pulse Multiplier	P4-04 Pulse Multiplier	000.01 – 500.00	100.00	
	P4-05	Flow Meter Offset	P4-05 Flow Meter Offset	0.00 - 0.99	0.00	
Energy Monitoring	P5-01	Energy Cost per kWh	P5-01 Energy Cost per kWh	0.000 - 5.000\$	0.000\$	
	P5-02	Reset Energy Usage	P5-02 Reset Energy Usage	0: No 1: Reset	0	

Engineering Units Selection by Parameter P1-01

Setting	Engineering Unit	Description
0	Set by Cn - 28	
1	%	%
2	PSI	PSI
3	GPH	gallon / hour
4	GPM	gallon / minute
5	inW	Inch water
6	FPM	feet / minute
7	CFM	feet ³ / minute
8	in	inch
9	ft	feet
10	HP	HP
11	°F	°F
12	m/s	meter / second

Setting	Engineering Unit	Description
13	MPM	meter / minute
14	CMM	meter ³ / minute
15	W	W
16	kW	kW
17	°C	°C
18	m	meter
19	A	A
20	RPM	RPM
21	SPM	stroke/minute
22	/s	unit / s
23	/m	unit / m
24	/h	unit / h
25	-	none

Table 9.1.5 Un- □□ Monitoring Parameters

Parameter No.	Name	LCD display (English)	Unit	Description	Multi-function Analog Output Level
Un-01	Frequency Command	Un-01 = 60.00Hz Frequency Command	0.01Hz	Display frequency command. The displayed unit is determined by Cn-28.	10V / MAX. Output Frequency
Un-02	Output Frequency	Un-02 = 60.00Hz Output Frequency	0.01Hz	Display output frequency. The displayed unit is determined by Cn-28.	10V / MAX. Output Frequency
Un-03	Output Current	Un-03 =12.5A Output current	0.1A	Display inverter output current.	10V / Inverter Rated Current
Un-04	Output Voltage	Un-04 =220.0V Output Voltage	0.1V	Display output voltage command of inverter	10V / 230V or 10V / 460V
Un-05	Main Circuit DC Voltage	Un-05 =310.0V DC Voltage	0.1V	Display DC voltage of inverter main circuit.	10V / 400V or 10V / 800V
Un-06	External Analog Command VIN	Un-06 =100% Voltage -Cmd.	0.1%	—	10V/100%
Un-07	External Analog Command AIN	Un-07 =100% Current -Cmd.	0.1%	—	20mA/100%
Un-08	Multi-Function Analog Input Command AUX	Un-08 =100% Multi_Fun -Cmd.	0.1%	—	10V/100%
Un-09	External Analog Output AO1	Un-09 =100% Term.AO1 Output	0.1%	—	10V/100%
Un-10	External Analog Output AO2	Un-10 =100% Term.AO2 Output	0.1%	—	10V/100%
Un-11	Input Terminal Status	Un-11= 00000000 I/P Term. Status	—	<p>0:OPEN 1:CLOSE</p> <p>Input terminal① Input terminal② Input terminal③ Input terminal④ Input terminal⑤ Input terminal⑥ Input terminal⑦ Input terminal⑧</p>	—

Cont.

Parameter No.	Name	LCD display (English)	Unit	Description	Multi-function Analog Output Level
Un-12	Output Terminal Status	Un-12= 00000000 O/P Term. Status	—		—
Un-13	Amount of PG Speed Feedback	Un-13 = 100.0% PG Feedback.	0.1%	100.0%=MAX. output frequency	10V / Max. output frequency
Un-14	Amount of PG Speed Compen.	Un-14 = 100.0% PG Compen.			
Un-15	PID Control Input	Un-15 = 100% PID Input			
Un-16	PID Control Output 1	Un-16 = 100% PID Output1			
Un-17	PID Control Output 2	Un-17 = 00% PID Output2			
Un-18	Fault Message 1	Overcurrent Message 1	—	Fault message occurred last	—
Un-19	Fault Message 2	Overcurrent Message 2	—	Fault message occurred previous	—
Un-20	Fault Message 3	Overheat Message 3	—	Fault message occurred two times previous	—
Un-21	Fault Message 4	Excess Load Message 4	—	Fault message occurred three times previous	—
Un-22	The Time Period Between Last Fault And The Current Fault.	Un-22 = 2400Hr Last Fault Run Time	1Hr	The value of 'Run Elapse Time' parameter will be cleared after fault has been cleared.	—
Un-23	Frequency Command When Fault Occurs	Un-23 = 60.00Hz Last Fault Freq.Cmd.	0.01Hz	—	—
Un-24	Output Freq. When Fault Occurs	Un-24 = 60.00Hz Last Fault O/P Freq.	0.01Hz	—	—
Un-25	Output Current When Fault Occurs	Un-25 = 12.5A Last Fault O/P I	0.1A	—	—

Cont.

Parameter No.	Name	LCD display (English)	Unit	Description	Multi-function Analog Output Level
Un-26	Output Voltage When Fault Occurs	Un-26 = 220.0V Last Fault O/P V	0.1V	—	—
Un-27	DC Voltage When Fault Occurs	Un-27 = 310.0V Last Fault O/P V	0.1V	—	—
Un-28	I/P Terminal Status While Fault Occurs	Un-28 = 00000000 Last Fault I/P Term.	—	Same as Un-11, display terminal status	—
Un-29	O/P Terminal Status When Fault Occurs	Un-29 = 00000000 Last Fault O/P Term.	—	Same as Un-12, display terminal status	—
Un-30	Time Elapsed After Power-On	Un-31 = 00002Hr P Elapsed Time	1Hr	Display total time elapsed after power ON	—
Un-31	Time Elapsed After Run	Un-31= 00002Hr R Elapsed Time	1Hr	Display total time elapsed after pressing RUN	—
Un-32	EPROM S/W Version	Un-32 = 00001 Soft Number	—	-Manufacturing use-	—
Un-33	Feedback Motor Speed	Un-33 = 00000rpm Motor Speed	1rpm	Display motor speed while PG feedback is set.	10V/MAX. Motor Speed
Un-34	PID Feedback Display	Un-34 = 00000 PID Feedback	*1	Displays PID feedback signal	
Un-35	During PID Sleep	Un-35 During PID Sleep	0 or 1	Displays whether or not the inverter is in the sleep mode.	
Un-36	Output Power	Un-36 Output Power	0.0 - 999.9 kW	Displays the power output in kW	
Un-37	Energy Used in kWh	Un-37 Energy Used in kWh	0.0 - 999.9 kWh	Displays the energy usage in kWh	
Un-38	Energy Used in MWh	Un-38 Energy Used in MWh	0.0 - 50000 MWh	Displays the energy usage in MWh	
Un-39	Energy Cost in \$	Un-39 Energy Cost in \$	0 - 9999 \$	Displays the energy usage in Dollars (\$)	
Un-40	Energy Cost in 10000\$	Un-40 Cost in 10000\$	0 - 25000 (0\$ - 250 Mil\$)	Displays the energy usage in Ten Thousand Dollar Units (\$)	

Cont.

Parameter No.	Name	LCD display (English)	Unit	Description	Multi-function Analog Output Level
Un-41	Flow Meter	Un-41 Flow Meter	GPM	Displays Gallons per Minute (GPM)	
Un-42	Ext. PID Feedback	Un-42 Ext. PID Feedback	%	Displays the External PID Feedback Value	
Un-43	Ext. PID Input	Un-43 Ext. PID Input	%	Displays the External PID Set Point Value	
Un-44	Ext. PID Output 1	Un-44 Ext. PID Output 1	%	Displays the External PID Output Value	
Un-45	Ext. PID Output 2	Un-45 Ext. PID Output 2	%	Displays the External PID Output (2) Value	

*1. The unit can be changed through parameter P1-01.

9.2 Parameter Detail

9.2.1 Parameters Bn- (Parameter Groups that can be Changed During Running)

Bn-01 - Acceleration Time 1 (0.0 – 6000.0s)

Bn-02 - Deceleration Time 1 (0.0 – 6000.0s)

Bn-03 - Acceleration Time 2 (0.0 – 6000.0s)

Bn-04 - Deceleration Time 2 (0.0 – 6000.0s)

- Set individual Acceleration/Deceleration times
- Acceleration time: The time required to go from 0% to 100% of the maximum output frequency.
- Deceleration time: The time required to go from 100% to 0% of the maximum output frequency.
- Using one of the multi-function inputs terminals ⑤-⑧, two different acceleration / deceleration times set by (1st) Bn-01& Bn-02 and (2nd) Bn-03 & Bn-04 may be selected by opening or closing an external switch contact. This switching can be done while the drive is operating. (See Fig. 9.2.1.1 below)

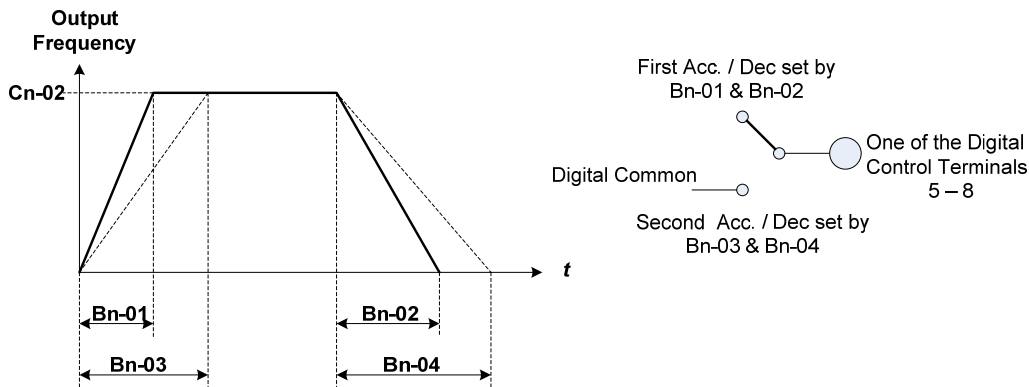

Fig. 9.2.1.1 Two Separate Acceleration and Deceleration Times

Note:

S-curve characteristic times can be set for beginning-accel., end-accel., beginning-decel. and end-decel. using parameters Cn-41 to Cn-44.

Bn-05 - Analog Frequency Command Gain (Voltage) (0.0 – 1000.0%)

Bn-06 - Analog Frequency Command Bias (Voltage) (-100.0 – 100.0%)

Bn-07 - Analog Frequency Command Gain (Current) (0.0 – 1000.0%)

Bn-08 - Analog Frequency Command Bias (Current) (-100.0 – 100.0%)

Bn-09 - Multi-function Analog Input Gain (0.0 – 1000.0%)

Bn-10 - Multi-function Analog Input Bias (-100.0 – 100.0%)

For each analog input frequency command (voltage or current) and multi-function analog inputs, the corresponding gain and bias should be set using parameters Bn-05 to Bn-10. (See Fig. 9.2.1.2)

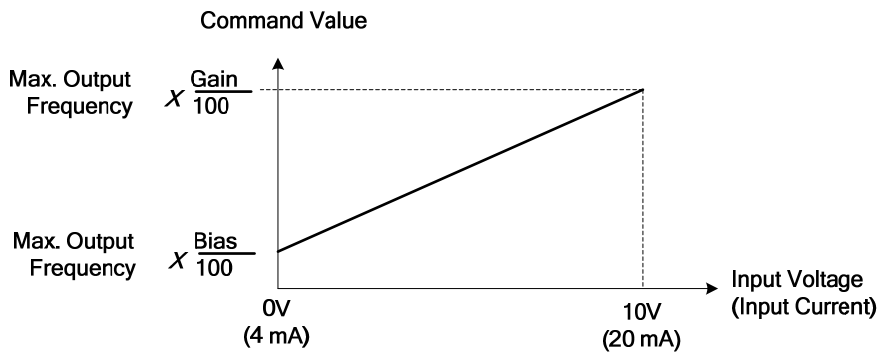

Fig. 9.2.1.2 Analog Input Gain and Bias

Bn-11 - Auto Torque Boost Gain (0.0 – 2.0)

The inverter can automatically increase the output torque of the drive to compensate for load increases using the auto torque boost function. In the case that the wiring distance between the inverter and the motor is excessive (e.g. more than 100m), the motor torque may become insufficient because of the voltage drop. To compensate for this, increase the value of Bn-11 gradually but make sure that the current increase is not excessive. Normally however, no adjustment is necessary.

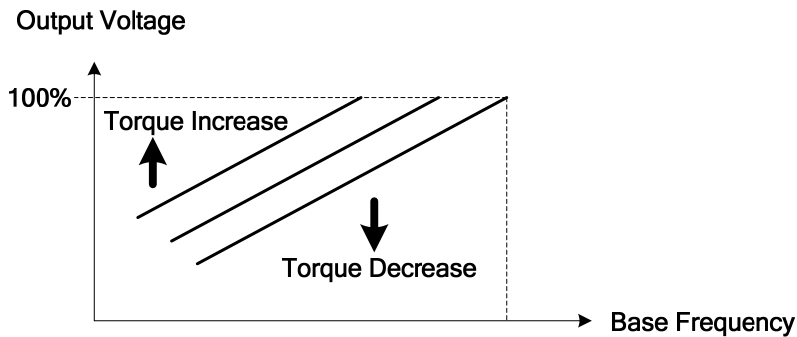

Fig. 9.2.1.3 Adjust Auto Torque Boost Gain to Increase Output Torque

- If the drive motor capacity is less than the inverter capacity (Max. applicable motor capacity), increase the setting.
- If the motor oscillates excessively, lower the setting.

Bn-12 - Monitor 1 (1 – 30)

Bn-13 - Monitor 2(1 – 30)

- In the DRIVE mode, 2 inverter input / output statuses can be monitored at the same time. The specified items are set by parameters Bn-12 and Bn-13. Refer to Table 9.2.1.1 below for the selectable monitored items.

Table 9.2.1.1a Setting of Bn-12 and Bn-13 Monitoring contents

Bn-12 or Bn-13 Setting	Monitoring contents	Description
01	Freq.Cmd.	Frequency Command
02	O/P Freq.	Output Frequency
03	O/P I	Output Current
04	O/P V	Output Voltage
05	DC Volt	Main Circuit DC Voltage
06	Term. VIN	Terminal Command VIN
07	Term. AIN	Terminal Command AIN
08	Term. AUX	Terminal Command AUX
09	x Output	Analog Output AO1
10	x Output	Analog Output AO2
11	I/P Term	Input Terminal Status
12	O/P Term	Output Terminal Status
13	Sp. FBK	PG Speed Feedback
14	Sp. Compen.	PG Speed Compensation
15	PID I/P	PID Input
16	PID O/P	PID Output 1
17	PID O/P	PID Output 2
18	Motor Sp.	Motor Speed

Cont.



- For versions 77.01 and later, eight additional monitor items were added for HVAC applications and are listed in Table 9.2.1.1b below.

Table 9.2.1.1b Setting of Bn-12 and Bn-13 Monitoring contents

Bn-12 or Bn-13 Setting	Monitoring contents	Description
19	PID FBK.	PID Feedback
20	PID Sleep	PID Sleep Status
21	O/P Power	Output Power
22	Reserved	Reserved
23	Reserved	Reserved
24	Reserved	Reserved
25	Reserved	Reserved
26	FLOW	Flow Meter Display
27	E_PID FBK	External PID Feedback
28	E_PID I/P	External PID Input
29	E_PID O/P	External PID Output 1
30	E_PID O/P	External PID Output 2

- Some examples:

Example	Bn -	Display
(1)	Bn-12= 02	O/P Freq. 15.00Hz
	Bn-13= 01	Freq.Cmd. 15.00Hz
(2)	Bn-12= 03	O/P I 21.0A
	Bn-13= 05	DC Volt 311V
(3)	Bn-12= 11	I/P Term. 00101010
	Bn-13= 12	O/P Term. 00010010

Note: While monitoring, use the  or  key to display the information for the next lower-row. The setting of Bn-12 and Bn-13 does not change.

Bn-14 - Multi-function Analog Output AO1 Gain (0.01 – 2.55)

Bn-15 - Multi-function Analog Output AO2 Gain (0.01 – 2.55)

The output voltage of the Multi-function analog outputs AO1 and AO2 can be set (scaled) using parameters Bn-14 and Bn-15 respectively.

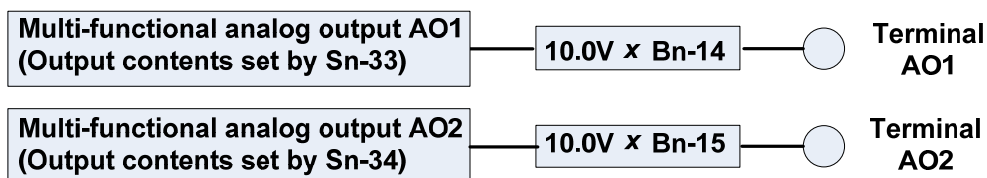

- Bn-16** - PID Detection Gain (0.01 – 10.00)
- Bn-17** - PID Proportional Gain (0.01 – 10.00)
- Bn-18** - PID Integral Time (0.00 – 100.00s)
- Bn-19** - PID Differential Time (0 – 1.00s)
- Bn-20** - PID Bias (0 - 109%)

Refer to: App-1 PID Application Note for further information and application details.

Bn-21 to Bn-36 - Time Setting in Auto_Run Mode In Auto_Run mode, the time setting for individual steps is described in “(Sn-44-60) auto run mode selection and enable”. (0.0 – 6000.0s)

- Bn-37** - Timer ON_Delay Time (0.0 – 6000.0s)
- Bn-38** - Timer OFF_Delay Time (0.0 – 6000.0s)

- The timer function is enabled when the timer function input setting (Sn-25-28=19) and the output setting (Sn-30-32=21) are set for multi-function input and output respectively.
 - These inputs and outputs serve as general-purpose I/O's. Setting ON/OFF delay time (Bn-37 / Bn-37) for the timer can prevent input switch contact bounce etc.
 - When the timer input ON time is longer than the value set for Bn-37, the timer function output turns ON.
 - When the timer input OFF time is longer than the value set for Bn-38, the timer function output turns OFF.
- An example is shown below in Fig. 9.2.1.4.

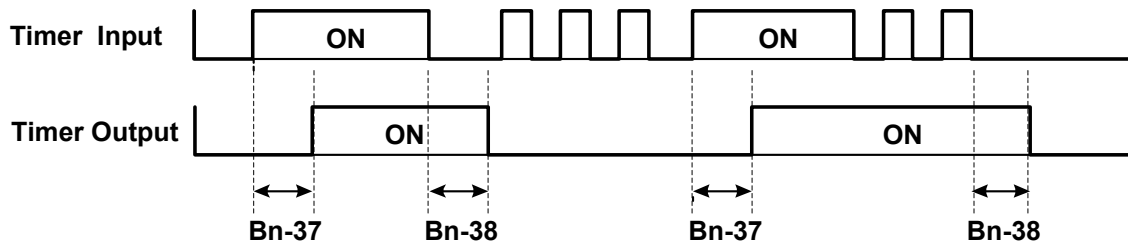

Fig. 9.2.1.4 Timer Input / Output Example

Bn-39 - Energy Saving Gain (50 – 150%)

- The input the energy saving command causes the inverter output voltage to be reduced when the motor load is light, thus saving energy. This value is set as a percentage of the V/F pattern. The setting range is 50 - 150%. When Bn-39 is set to 100% (factory default) the energy saving function is disabled. When Bn-39 is not set to 100%, the energy saving function is enabled.
- In the energy saving mode (Bn-39 ≠ 100), the output voltage will automatically decrease and be proportional to energy saving gain Bn-39. The Bn-39 setting should not be so small that the motor will stall.
- The energy saving function is disabled when using PID close-loop control and during acceleration and deceleration.

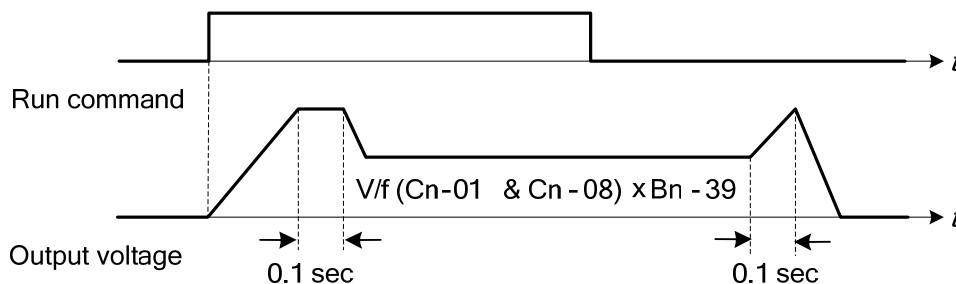

Fig. 9.2.1.5 Energy Savings Time Chart

Bn-40 - Monitor 3 (00 – 30)

- This parameter sets the display contents immediately after power is applied.
- When Bn-40 = 00, and power is applied, the first line will display frequency command value, while the second line will display the characters “TECO” as shown in the following diagram:



- When Bn-40 = 01 - 30, the display will show the set monitored items after power is applied. The first line of the display content is determined by Bn-12. The second line is determined by Bn-40 as shown in the following example:

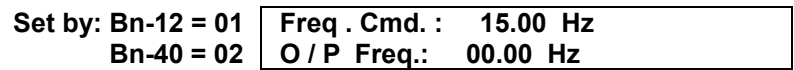

- Bn-40 = 01-30 parameter description is same with Bn-12, Bn-13. Refer to Tables 9.2.1a and 9.2.1b, “Setting of Monitoring Contents”.

Bn-41 to Bn-44 - Pulse Input setting (1440 – 32000)

- Set Sn-05 = 3 before starting Pulse Input function. Refer to parameter Sn-05 for details.
- Refer to the following Fig.9.2.1.6.

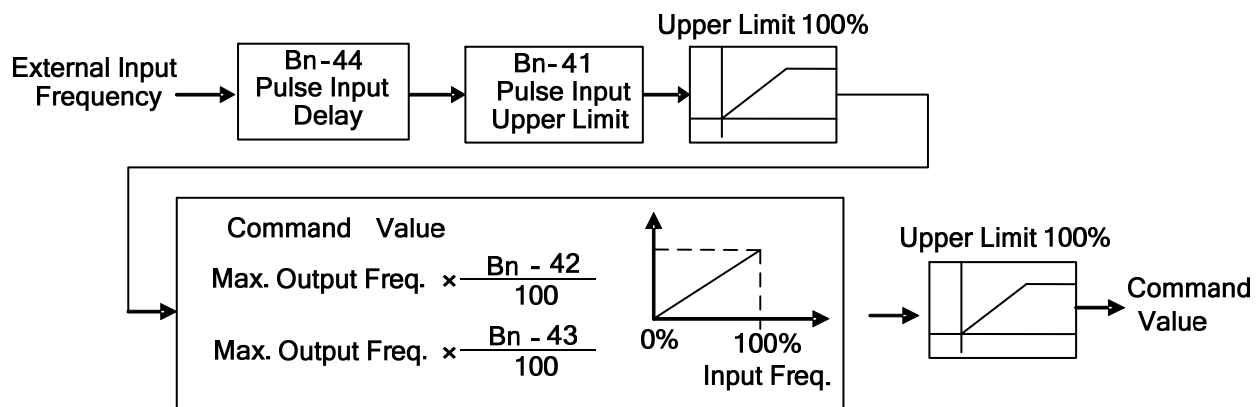

Fig. 9.2.1.6 Pulse Input Function

Bn-45 - PID Feedback Display at 0%

Bn-46 - PID Feedback Display at 100%

These parameters are not available for software version 77.01 and later. In this case Use parameter Feedback Maximum (P1-02). See P parameters for details.

9.2.2 Parameters Cn- (Control Parameters)

Cn-01 - Input Voltage Setting (Range depends on inverter voltage class. See parameter summary)

- Set the inverter voltage to match the input power supply voltage (e.g. : 200V / 230V, 380V /415V /440V /460V / 575V)

Cn-02 to Cn-08 - V/F Curve Parameter Settings (See parameter summary for setting range)

- The V/F curve can be set to either one of the preset curves (Sn-02 = 0 -14) or a customer set curve (Sn-02 = 15).
- Cn-02 - Cn-08 can be set by the user when Sn-02 is set to 15. The user-defined V/F curve can be specified using the settings of Cn-02 - Cn-08 as shown in Fig. 9.2.2.1a. The factory default setting is a straight line for the V/F curve (Cn-05=Cn-07, Cn-06 is not used) as shown below in Fig. 9.2.2.1b for the 230V / 60Hz example.

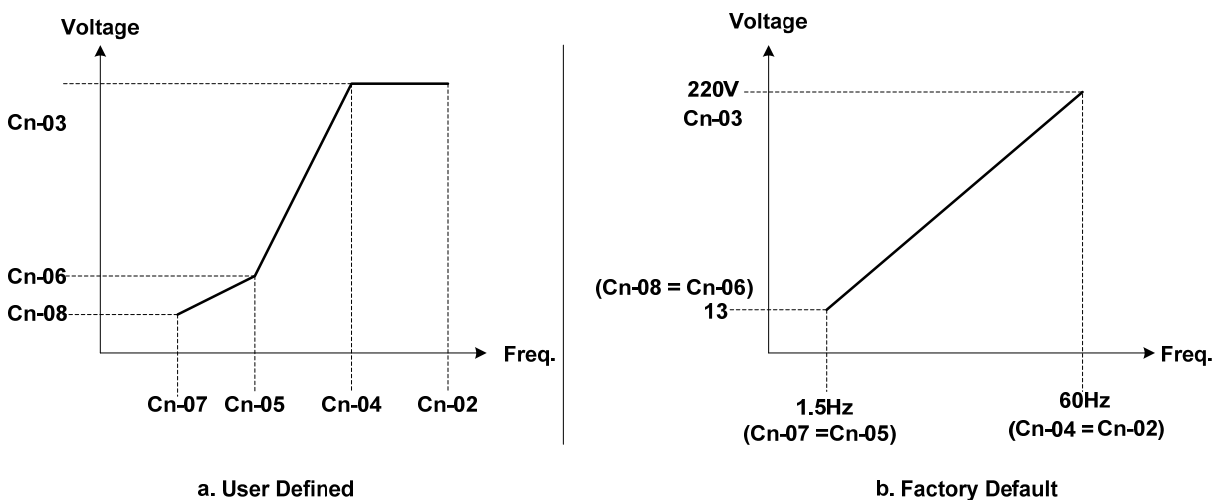

Fig. 9.2.2.1 User Defined V/F Curve

- When operating at low speed (<3Hz), a larger torque can be generated by increasing the slope of V/F curve. However, the motor temperature will increase due to over-excitation and may result in a fault. Based on the applied load, adjust the V/F curve and observe the magnitude of the motor current.
- The four frequency settings must satisfy the following relationship, otherwise an error message “V/F Curve Invalid” will be displayed.
 - (a) Max. output freq. ≥ Max. voltage freq. > Mid. Output freq. ≥ Min. output freq.
 (Cn-02) (Cn-04) (Cn-05) (Cn-07)
 - (b) Max. output volt. ≥ Mid. output volt. > Min. output voltage
 (Cn-03) (Cn-06) (Cn-08)
- If Mid. Output frequency (Cn-05) = Min. output frequency (Cn-07), the setting (Cn-06) is not effective.

Cn-09 Motor Rated Current (10% - 200% of the inverter rated output current)

- Electronic overload thermal reference current
- The factory setting depends upon the capacity type of inverter (Sn-01).
- The setting range is 10% - 200% of the inverter rated output current.
- Set the rated current to that shown on the motor nameplate if not using a TECO 4-pole motor.

Cn-10 Motor No-Load Current (0 – 99%)

- This setting is used as a reference value for torque the compensation function.
- The setting range is 0 - 99% of the inverter rated current Cn-09 (100%).
- The slip compensation is enabled when the output current is greater than motor no-load current (Cn-10). The output frequency will shift from f1 to f2 (>f1) for the positive change of load torque. (See Fig. 9.2.2.2)

$$\text{Slip compensation} = \frac{\text{Motor rated slip (Cn-11)} \times (\text{Output current} - \text{Motor no-load current(Cn-10)})}{\text{Motor rated current (Cn-09)} - \text{Motor no-load current (Cn-10)}}$$

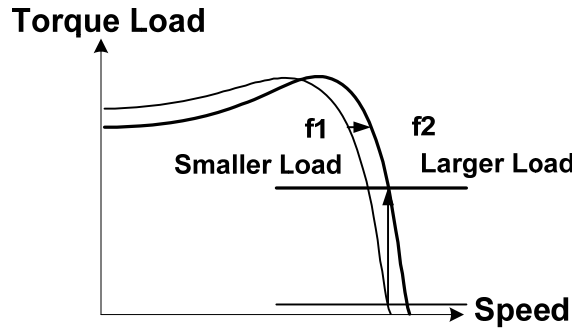

Fig. 9.2.2.2 Output Frequency with Slip Compensation

Cn-11 Motor Rated Slip (0.0 - 9.9%)

- This setting is used as a reference value for the torque compensation function (See Fig. 9.2.2.3). The setting range is 0.0 - 9.9% of the motor maximum voltage frequency with Cn-04=100%.
- The setting is shown in Fig. 9.2.2.3 in the constant torque and constant output range. If setting Cn-11 is zero, no slip compensation is used.
- There is no slip compensation when the frequency command is less than the Min. output frequency or during regeneration.

$$\text{Motor rated slip (Cn-11)} = \frac{\text{Motor rated freq. (Hz)} \times (\text{Rated speed (RPM)} - \text{Motor No. of poles})}{\text{Max-voltage freq (Cn-04)} \times 120} \times 100\%$$

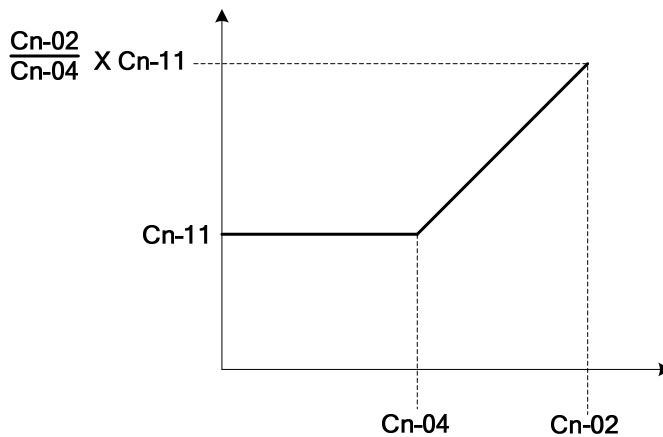

Fig. 9.2.2.3 Slip Compensation Limit

Cn-12 Motor Line-to-Line Resistance (0 – 65.535Ω)

Cn-13 Motor Iron-Core Loss (0 – 65535W)

This parameter is used for the torque compensation function. The default setting depends on the inverter capacity (Sn-01). Normally, the setting does not need to be changed. See Table 10 - 11 on page 3-36.

Cn-14 DC Injection Braking Starting Frequency (0.1 – 10.0Hz.)

Cn-15 DC Injection Braking Current (0 – 100%)

Cn-16 DC Injection Braking Time at Stop (0.0 – 25.5 Sec.)

Cn-17 DC Injection Braking Time at Start (0.0 – 25.5 Sec.)

- The DC injection braking function decelerates the motor by applying a DC current to the motor windings and is active in the following two cases:
 - a.) DC injection braking time at start: This is used to temporarily stop and then restart a motor coasting from inertia in a drive without regeneration.
 - b.) DC injection braking time at stop: This is used to prevent the motor from coasting over an extended time due to a high inertia load. Increasing the DC injection braking time (Cn-16) or increasing the DC injection braking current (Cn-15) will decrease the stopping time.
- The DC injection braking current parameter (Cn-15) sets the current level that is active at the time of DC injection braking. The braking current is set as a percentage of inverter rated output current at 100%.
- The DC injection braking start time (Cn-17) starts when the motor is started.
- The DC injection braking start frequency (Cn-14) is set at the point where the DC injection braking for deceleration is to begin. If this frequency is less than the Min. output frequency (Cn-07), the DC injection braking will then begin at the Min. output frequency.
- If the DC injection braking time at start (Cn-17) is 0.0s, the motor starts from the Min. output frequency (Cn-07) and DC injection braking is not enabled.
- If the DC injection braking time at stop (Cn-16) is 0.0s, DC injection braking is not enabled. In this case, the inverter output will be blocked when the output frequency is less than the DC injection braking at the start frequency (Cn-14).

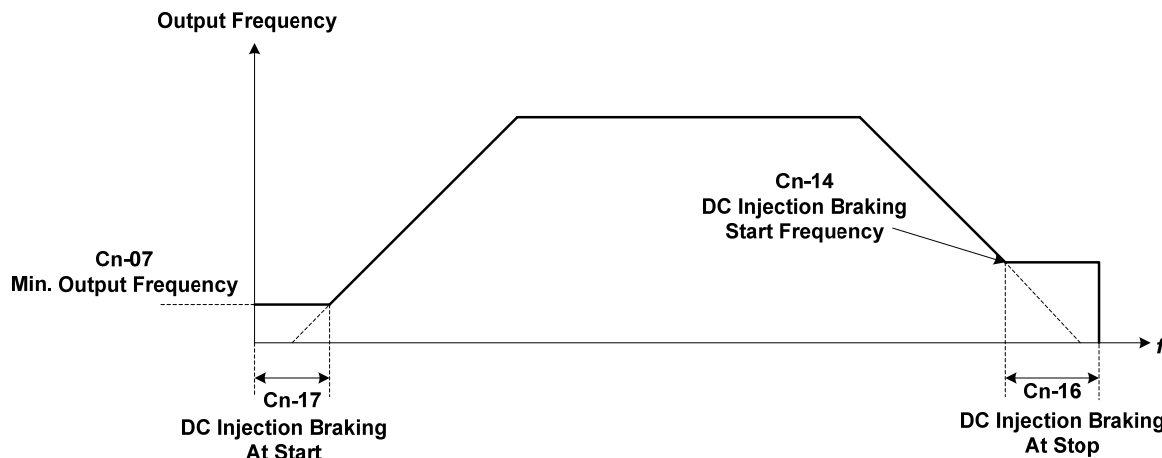

Fig. 9.2.2.4 DC Injection Braking Time Chart

Cn-18 Frequency Command Upper Bound (0 – 109%)

Cn-19 Frequency Command Lower Bound (0 – 109%)

- The upper and lower bounds of the frequency command are set as a percentage of the Max. output frequency (Cn-02 is 100%), in increments of 1%.
- The relationship $Cn-18 > Cn-19$ must be maintained otherwise an error message, "Freq. Limit Setting Error" may occur.

Cont.

- When the frequency command is zero and a run command is input, the motor operates at the frequency set by the lower bound parameter (Cn-19). However, the motor will not operate if the lower limit is set below the Min. output frequency (Cn-07).

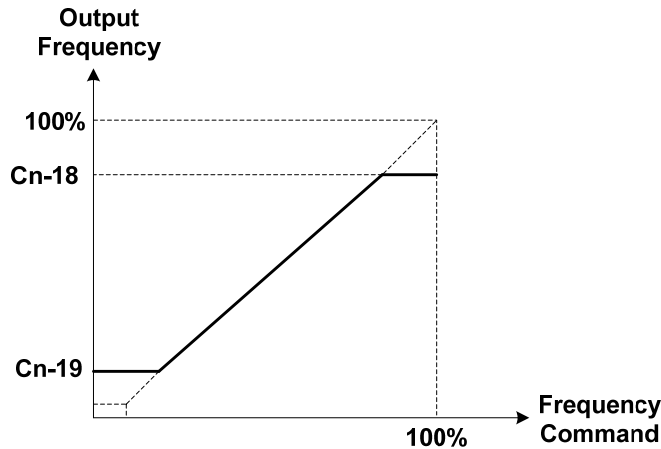

Fig. 9.2.2.5 Upper and Lower Bound of the Frequency Command

Cn-20 Frequency Jump Point 1 (0.0 – 400.0Hz.)

Cn-21 Frequency Jump Point 2 (0.0 – 400.0Hz.)

Cn-22 Frequency Jump Point 3 (0.0 – 400.0Hz.)

Cn-23 Jump Frequency Width (0.0 –25.5Hz.)

- These parameters allow the “jumping over” of certain frequencies that can cause unstable operation due to resonance within some driven systems.

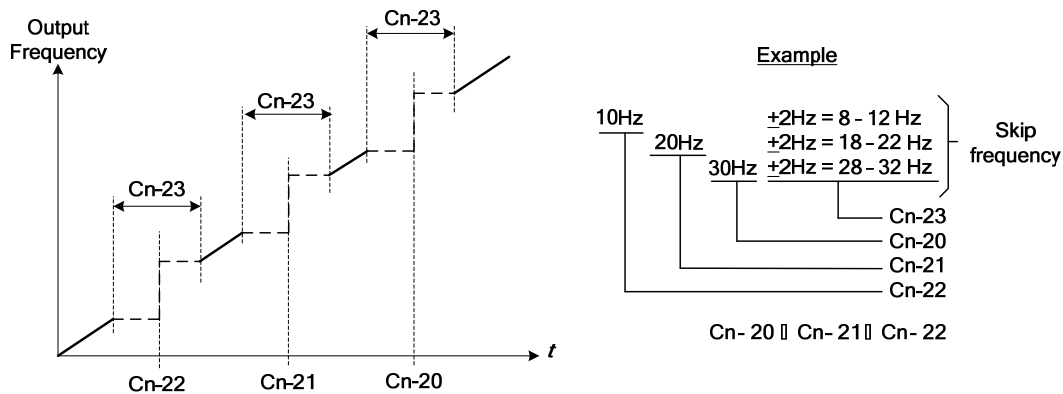



Fig. 9.2.2.6 Jump Frequency Settings

- Operation within the jump frequency range is not allowed, but transitions during acceleration and deceleration through these set ranges are smooth with no jump. To disable this function, set the jump frequencies 1-3 (Cn-20 - Cn-22) to 0.0Hz.
- For the jump frequencies 1 - 3 (Cn-20 - Cn-22), set the center frequency to be jumped.
- Be sure to set the jump frequencies so that $Cn-20 \geq Cn-21 \geq Cn-22$. If not, a message “Jump frequency setting error” will be displayed. Parameter Cn-23 sets the jump frequency bandwidth. If Cn-23 is set to 0.0Hz, the jump frequency function is disabled.

Cn-24 Number of Auto Restart Attempts (1 – 10)

- The fault restart function will restart the inverter even when an internal fault occurs during inverter operation. Use this function only when continuing operation is more important than possibly damaging the inverter.
- The fault restart function is active when the following faults occur.
Over-current, Ground fault and Main circuit Over-voltage
 With other faults, the protective operations will engage immediately without attempting to restart operation.
- The fault restart count will automatically increase upon each attempted restart. If the drive restarts within the set number of accumulated tries then the count will be reset to 0 when the operation is normal for 10 minutes. If the accumulated number of tries exceeds the set count then no further attempts will be made and the drive will only start when the fault is cleared and the fault-reset input is received. (e.g., by pressing  or enabling the Fault reset terminal ③) or when the power is turned off and on again.
- When one of the multi-function output terminals (RA-RB-RC or R1A-R1B-R1C, DO1, DO2 or R2A-R2C) is set to restart enabled, the output will be on while the fault restart function is in progress. (See parameters Sn-30 – Sn-32).

Cn-25 Stall Prevention Level During Acceleration (30 – 200%)

Cn-26 Stall Prevention Level During Running (30 – 200%)

- A motor stall can occur when a large load is applied or on sudden acceleration with a high inertia load. In this case, the inverter should automatically adjust the output frequency to prevent stall.
- The stall prevention function can be set independently for accelerating and running.
- Stall Prevention During Acceleration: Acceleration will stop if Cn-25 setting is exceeded. The acceleration will resume when the current is less than Cn-25. (See Fig. 9.2.2.7a.)
- Stall Prevention During running: Deceleration is started if the run stall prevention level Cn-26 is exceeded. Acceleration will resume when the current level is less than Cn-26. (See Fig. 9.2.2.7b.)

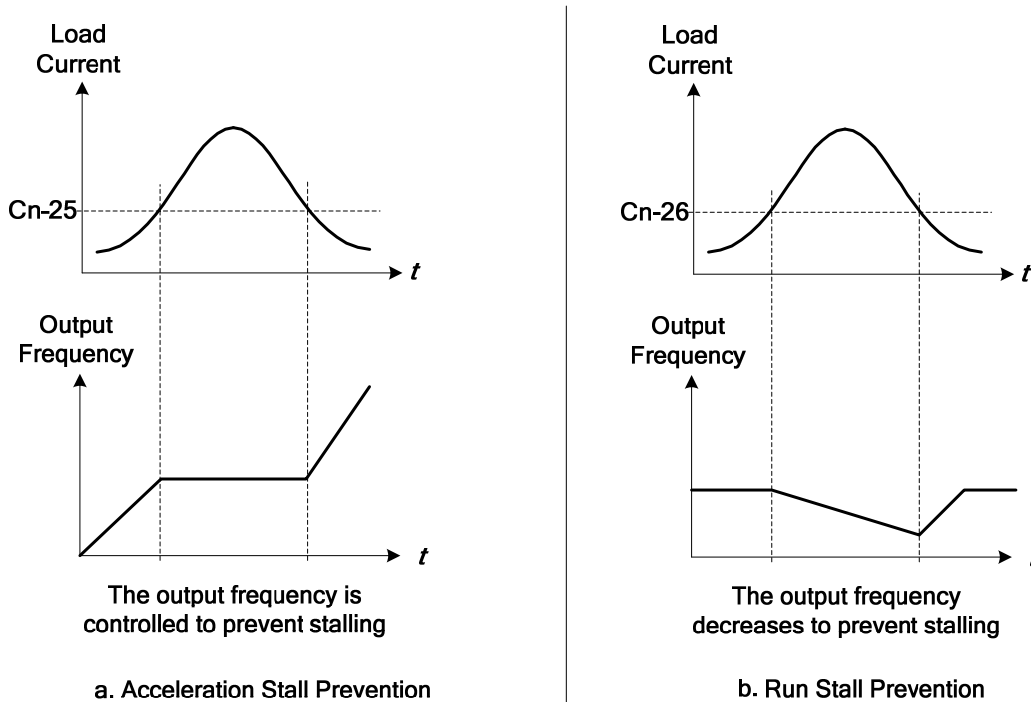

Fig. 9.2.2.7 Stall Prevention Function

- Set the parameters Cn-25 and Cn-26 as a percentage of inverter rated current. (100% corresponds to inverter rated current).
- See page 3-45, 3-46 for stall prevention function selection.

Cn-27 Communication Fault Detection Time (0.1 - 25.5s)
 Please refer to “MODBUS / PROFIBUS Application Manual”.

Cn-28 LCD Digital Operator Display Unit (0 – 39999)

- This parameter sets the units to be displayed for the frequency command and frequency monitoring as described below in the following Table 9.2.2.1.

Table 9.2.2.1 Digital Operator Display Units

Cn-28	Setting / Reading Content
	Frequency Command / Monitoring
0	Units of 0.01 Hz
1	Units of 0.01%
2 to 39	Set in the units of r / min (0 to 39999). $r / min = 120 \times \text{frequency reference (Hz)} / \text{Cn-28}$ (Set the number of motor poles in Cn-28, only even data is allowed)
40 to 39999	The position of decimal point is set by the value of the 5th digit of Cn-28. 5th digit = 0: Displayed as XXXX 5th digit = 1: Displayed as XXX.X 5th digit = 2: Displayed as XX.XX 5th digit = 3: Displayed as X.XXX The 1st digit to 4th digits of Cn-28 set the value of 100% frequency.

Example 1:

If 200.0 represents a speed of 100%, Cn-28 = 12000.
 60% speed is displayed as 120.0

Example 2:

If 65.00 represents a speed of 100%, Cn-28 = 26500.
 60% speed is displayed as 39.00

- The function of Cn-28 is valid while the Engineering Unit (P1-01) is 0 (invalid). If the Engineering Unit (P1-01) is set to nonzero value, the frequency command display format is then set by P1-01 and P1-02.

Cn-29 Frequency Agree Detection Level During Acceleration (0.0 – 400.0Hz.)

Cn-30 Frequency Agree Detection Level During Deceleration(0.0 – 400.0Hz.)

Cn-31 Frequency Agree Detection Width (0.10 – 25.5Hz.)

- Using parameters Sn-30 - Sn-32, the multi-function output terminals RA-RB-RC or R1A-R1B-R1C, DO1, DO2 or R2A-R2C can be programmed to output the desired Frequency Agree signal, Setting Frequency Agree and Output Frequency Detection level.
- The following Table 9.2.2.2 shows the various settings for the frequency detection function.

Cont.

Table 9.2.2.2 Frequency Detection Function

Function	Frequency Detection Operation	Description
Frequency Agree		<ul style="list-style-type: none"> When the Output freq. is within the Freq. command +/- Freq. detection width (Cn-31), the Frequency agree output is "ON". Set Sn-30 - Sn-32 to 02 (Frequency agree).
Setting Frequency Agree		<ul style="list-style-type: none"> After acceleration, when the Output freq. reaches the Freq. agree detection level, (Cn-29) and is within the Freq. agree detection width (Cn-31), the Agreed freq. output is "ON". Set Sn-30 - Sn-32 to 03 (Setting freq. agree.)
Output Frequency Detection 1		<ul style="list-style-type: none"> During acceleration, when the Output freq. is less than Freq. agree detection level (Cn-29), Output freq. detection 1 is "ON". During deceleration, when the Output freq. is less than Freq. agree detection level (Cn-30), Output freq. detection 1 is "ON". Set Sn-30 - Sn-32 to 04 (Output freq. detection 1)
Output Frequency Detection 2		<ul style="list-style-type: none"> During acceleration, when the Output freq. is greater than Freq. agree detection level (Cn-29), Output freq. detection 2 is "ON". During deceleration, when the Output freq. is greater than Freq. agree detection level (Cn-30), Output freq. detection 2 is "ON". Set Sn-30 - Sn-32 to 05 (Output freq. detection 2)

Cn-32 Excess Load Detection Level (0 – 200%)

Cn-33 Excess Load Detection Time (0.0 – 25.5s)

- The excess load Detection Function detects excessive mechanical load from an increase in output current.
- An excess load condition is detected when the output current exceeds the Excess Load Detection Level (Cn-32) for longer than the Excess Load Detection Time (Cn-33). (See Fig.9.2.2.8)
- The Multi-Function Output Terminals RA-RB-RC or R1A-R1B-R1C, DO1, DO2 or R2A-R2C can be set to indicate that an excess load condition has been detected.

Cont.

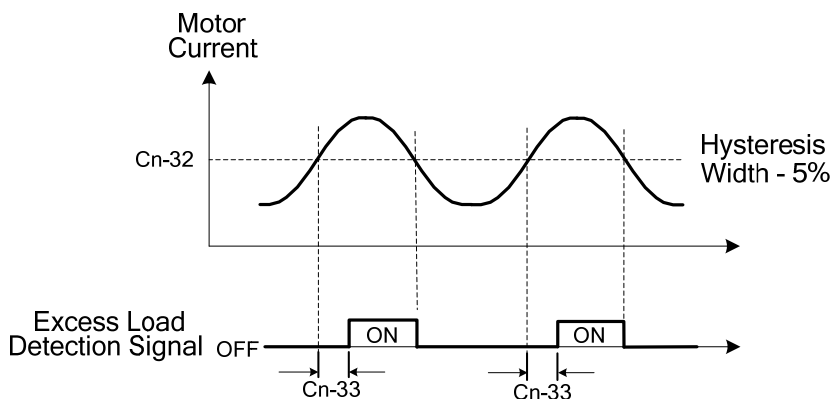

Fig. 9.2.2.8 Excess Load Detection

- Set the value of Sn-12 (Excess Load Detection Selection) to select:
 - Excess Load Detection only during speed agree- Stop output or continue running after excess load condition is detected.
 - Excess Load Detection at any time - Stop output, or continue running after excess load condition is detected.
- The excess load detection level (Cn-32) must be higher than the load loss detection level set by (P3-01), otherwise, an error message “Load Detection Setting Error” will be displayed.

Cn-62 Torque Detection Level 2

Cn-63 Torque Detection Time 2

Parameters Cn-62 and Cn- 63 are not available in version 77.01 and later. Use Cn-32 and Cn-33 to set excess load detection level and time, and use P3-02 and P3-03 to set load loss detection level and time.

Cn-34 Carrier Frequency Setting (1 – 6)

- Lowering the carrier frequency can decrease noise interference and leakage current. The settings are shown below.

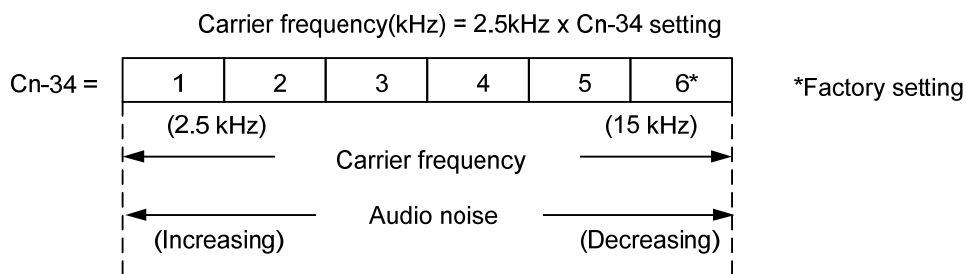

- The output frequency does not normally need to be adjusted, except in the following cases.
 - If the wiring distance between the inverter and motor is excessively long, lower the carrier frequency as shown below to minimize leakage current.

Wring distance	< 100ft.	100-165ft.	166-328ft.	≥ 329ft.
Carrier frequency (Cn-34)	<15kHz	<10kHz	<5KHz	<2.5KHz

- If there is instability in the speed or torque, lower the carrier frequency.

- Cn-35** Speed Search Detection Level (0 – 200%)
- Cn-36** Speed Search Time (0.1 – 25.5s)
- Cn-37** Min. Baseblock Time (0.5 – 5.0s)
- Cn-38** Speed Search V/F Curve (10 – 100%)

- The speed search function will search the speed (frequency) of a coasting motor starting with the frequency command or maximum frequency. Using this frequency value the motor will be restarted from this point providing a smooth recovery. This is effective in situations such as switching from a commercial power supply to an inverter without tripping.
- The timing of speed search function as shown in Fig. 9.2.2.9 below.

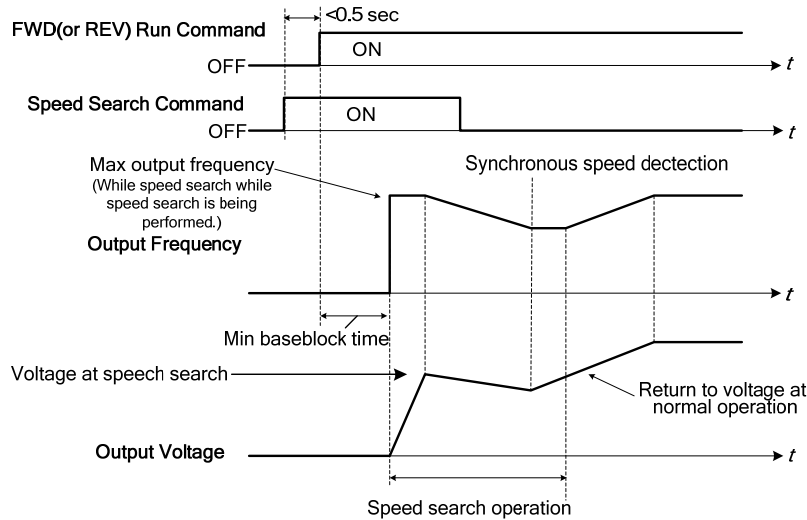
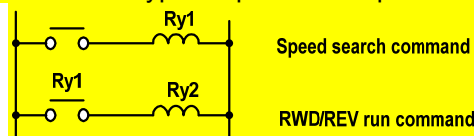

Fig. 9.2.2.9 Speed Search Timing Chart

- The speed search command can be set through one of the multi-function contact input terminals ⑤ - ⑧ using parameters Sn-25 - Sn-28.
 - If Sn-25 - Sn-28= 21: Speed search is performed from the Max. output frequency and motor is coasting freely.
 - If Sn-25 - Sn-28= 22: Speed search starts from the frequency command when the speed search command is enabled.
- After the inverter output is blocked, the user should input the speed search command and then enable the run operation. The inverter will begin to search the motor speed after the min. baseblock time set by parameter Cn-37.
- In speed search operation, if the inverter output current is less than Cn-35, the inverter will take the output frequency as the real frequency at that time. Using the values of real frequency, the inverter will accelerate or decelerate to the set frequency according to the acceleration or deceleration time.
- While the speed search command is being performed, the user can slightly decrease the setting of the V/F curve (Cn-38) in order to prevent the OC protection function from being enabled. Normally, the V/F curve need not be changed. (As below)
- The speed search operating V/F curve = Cn-38 x (normal operating V/F curve)
 - Notes: 1- The speed search operation will be disabled if the speed search command is enacted from the Max. frequency and the setting frequency. (I.e., Sn-25=20, Sn-26=21 and multi-function input terminals ⑤, ⑥ is used at the same time).
 - 2- The FWD/REV command must be performed after or at the same time the speed search command is enabled. A typical operation sequence is shown below.



- 3- When the speed search and DC injection braking are enabled, the Min. baseblock time (Cn-37) must be set long enough to allow for the motor's residual voltage to decrease. If an overcurrent is detected when starting a speed search and DC injection braking is active, increase the setting of Cn-37 to prevent a fault from occurring. As a result, the Cn-37 setting cannot be set too small.

Cn-39 Low Voltage Alarm Detection Level (Range depends on the inverter voltage class)

- In most cases, the default setting of Cn-39 need not be changed. If an external AC reactor is used, decrease the low voltage alarm detection level by decreasing the value of Cn-39. Be sure to set a main-circuit DC voltage so that a main circuit undervoltage is detected.

Cn-40 Slip Compensation Primary Delay Time (0.0 – 25.5s)

- In most cases, the setting Cn-40 need not be changed. If the motor speed is unstable, increase the value of Cn-40. If the speed of response is to low, decrease the value of Cn-40.

Cn-41 S-curve Characteristic Time at Acceleration Start (0.0 – 1.0s)**Cn-42** S-curve Characteristic Time at Acceleration End (0.0 – 1.0s)**Cn-43** S-curve Characteristic Time at Deceleration Start (0.0 – 1.0s)**Cn-44** S-curve Characteristic Time at Deceleration End (0.0 – 1.0s)

- Using the S-curve characteristic function for acceleration and deceleration can reduce mechanical shock to the machinery when stopping and starting. The S-curve characteristic time can be set respectively for beginning acceleration, ending acceleration, beginning deceleration and ending deceleration. The relation between these parameters is shown in Fig.9.2.2.10.

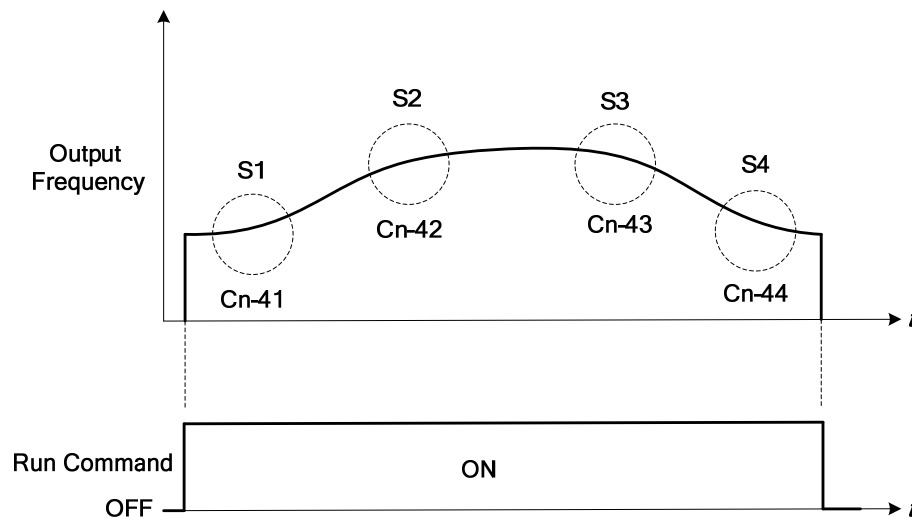
**Fig. 9.2.2.10 S Curve**

- After the S-curve time is set, the final acceleration and deceleration time will be as follows:

$$Acc. Time = Selected Acc. Time1 (or 2) + \frac{(Cn - 41) + (Cn - 42)}{2}$$

$$Decel. Time = Selected Decel. Time1 (or 2) + \frac{(Cn - 43) + (Cn - 44)}{2}$$

Cn-45 PG Parameter (0.0 – 3000.0 P/R)

The parameter sets the number of pulse/revolution for the PG. The factory setting is 0.1 P/R.

Cn-46 Pole Number of Motor (2 - 32)

Cn-45 and Cn-46 must meet the following relationship: $\frac{2 \times Cn - 45 \times Cn - 02}{Cn - 46} < 32767$ If not, an error message "PG Parameter Setting Error" will be displayed

Cn-47 ASR Proportion Gain 1(0.00 – 2.55)

Cn-48 ASR Integral Gain 1 (0.1 – 10.0s)

Set the proportion gain and integral time of the speed control (ASR).

Cn-49 ASR Proportion Gain 2 (0.00 – 2.55)

Cn-50 ASR Integral Gain 2(0.1 – 10.0s)

Use proportional gain and integral time settings for high-speed operation.

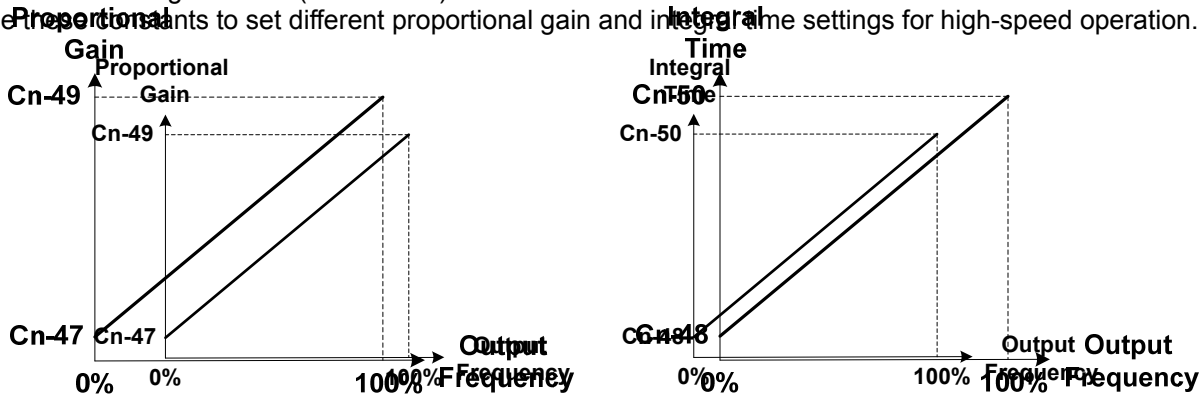

Fig. 9.2.2.11 ASR Proportional Gain and Integral Time

Cn-51 ASR Upper Bound

Cn-52 ASR Lower Bound

The settings of Cn-51 and Cn-52 will limit the ASR range.

Cn-53 Excessive Speed Deviation Detection Level (1 – 50%)

This parameter sets the level of detecting the PG speed deviation. The value of Cn-02 (Max. frequency) is referenced as 100%, the default unit setting is 1%.

Cn-54 Overspeed Detection Level (1 -120%)

Set this parameter for detecting overspeed. The value of Cn-02 (Max. frequency) is referenced as 100%, the default unit setting is 1%. Please refer to the setting of **Sn-53**.

Cn-55 PID Integral Upper Bound (0 – 109%)

Cn-56 PID Primary Delay Time Constant (0.0 – 2.5s)

Refer to "APP-1 PID Application Note" for more details.

Cn-57 Motor Line-to-Line Resistance R1 (0.001 – 60.000Ω) (See parameter summary)

- This parameter is used to set the motor's terminal resistance (including the motor external cable resistance) in Ohm's Ω.
- The default setting depends upon the inverter capacity and does not include the motor external motor cable resistance.

This value will be automatically set during auto-tuning. See "**Appendix A Auto-tuning Procedure / Sensorless Vector Control**"

- Increase the setting when the torque is not high enough at low speed.
- Decrease the setting when the torque is too high and cause an overcurrent trip at low speed.

Cn-58 Motor Rotor Equivalent Resistance R2 (0.001 – 60.000Ω) (See parameter summary)

- This parameter is used to set the motor's rotor Y-equivalent model resistance in Ohm's Ω .
- The default setting depends upon the inverter capacity. Normally this value is not shown on the motor's nameplate, therefore it may be necessary to contact motor manufacturer.

This value will be automatically set during auto-tuning. "**Appendix A Auto-tuning Procedure / Sensorless Vector Control**"

Cn-59 Motor Leakage Inductance Ls (0.01 – 200.00mH) (See parameter summary)

- This parameter sets the motor's rotor Y-equivalent model leakage inductance in mH.
- The default setting depends upon the inverter capacity.

This value will be automatically set during auto-tuning. "**Appendix A Auto-tuning Procedure / Sensorless Vector Control**"

Cn- 60 Motor Mutual Inductance Lm (0.1 – 6553mH) (See parameter summary)

- This parameter sets the motor Y-equivalent model mutual inductance in mH.
- The default setting depends upon the inverter capacity.

This value will be automatically set during auto-tuning. "**Appendix A Auto-tuning Procedure / Sensorless Vector Control**"

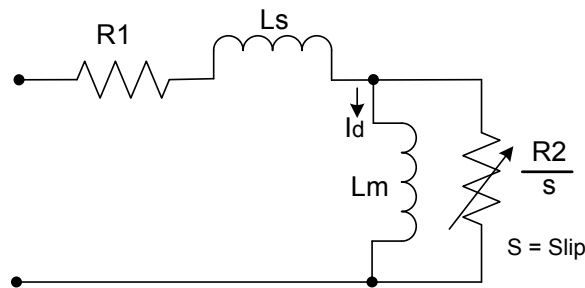

Fig. 9.2.2.12 Induction Motor Y-Equivalent Model

Cn - 61 Slip Compensation Gain

- Parameter Cn-61 is used to improve the speed accuracy while operating under load by providing slip compensation.
- Normally, the setting Cn-61 does need to be changed. However if the speed accuracy needs to be improved, then adjust Cn-61 accordingly. To decrease the actual speed change with load, increase the setting of Cn-61. Decrease the setting if the speed change over compensates or increases with load.

NOTES-

9.2.3 Parameters Sn- (System Parameters)

Sn-01 Inverter capacity selection

- The inverter capacity has already been set at factory in accordance with the following tables. If the control board is replaced, the setting Sn-01 must be reset to the value shown in the following tables.
- When the setting Sn-01 has been changed, the inverter system parameter settings should be changed based on the constant torque (CT) load (Sn-61= 0) or variable torque (VT) load (Sn-61= 1).

Table 9.2.3.1a 230V Class Inverter Capacity Selection

Sn-01 setting		001		002		003		004		005		006	
CT(Sn-61=0) VT(Sn-61=1)		CT	VT	CT	VT	CT	VT	CT	VT	CT	VT	CT	VT
Item Name													
Inverter rated capacity (KVA)		2		2.7		4		7.5		10.1		13.7	
Inverter rated current (A)		4.8		6.4		9.6		17.5		24		32	
Max. applicable capacity (HP) *2		1	1	2	2	3	3	5.4	7.5	7.5	10	10	10
Factory Setting	Cn-09	Motor rated current (A)	3.4	3.4	6.1	6.1	8.7	8.7	14.6	20.1	20.1	25.1	25.1
	Cn-12	Motor line impedance (Ω)	5.732	5.732	2.407	2.407	1.583	1.583	0.684	0.444	0.444	0.288	0.288
	Cn-13	Core loss torque compensation (W)	64	64	108	108	142	142	208	252	252	285	285
	Cn-34	Carrier freq.(kHz)	10	10	10	5	10	10	10	5	10	10	10
	Cn-37	Min. baseblock time (sec)	0.5	0.5	0.5	0.5	0.5	0.5	0.5	0.7	0.7	0.7	0.7
	Sn-02	V/F curve	01	07*1	01	07*1	01	07*1	01	07*1	01	07*1	01
Max. carrier freq. (kHz)		15	10	15	5	15	15	15	5	15	10	15	15

Sn-01 setting		007		008		009		010		011	
CT(Sn-61=0) VT(Sn-61=1)		CT	VT	CT	VT	CT	VT	CT	VT	CT	VT
Item Name											
Inverter rated capacity (KVA)		20.6		27.4		34		41		54	
Inverter rated current (A)		48		64		80		96		130	
Max. applicable capacity (HP) *2		15	20	20	25	25	25	30	40	40	40
Factory Setting	Cn-09	Motor rated current (A)	36.7	50.3	50.3	62.9	62.9	62.9	72.9	96.7	96.7
	Cn-12	Motor line impedance (Ω)	0.159	0.109	0.109	0.077	0.077	0.077	0.060	0.041	0.041
	Cn-13	Core loss torque compensation (W)	370	471	471	425	425	425	582	536	536
	Cn-34	Carrier freq.(kHz)	10	5	10	5	10	10	10	5	10
	Cn-37	Min. baseblock time (sec)	0.7	0.7	0.7	0.7	1.0	1.0	1.0	1.0	1.0
	Sn-02	V/F curve	01	07*1	01	07*1	01	07*1	01	07*1	01
Max. carrier freq. (kHz)		10	5	10	5	10	10	10	5	10	10

Cont.

Table 9.2.3.1b 460V Class Inverter Capacity Selection

Sn-01 setting			021		022		023		024		025		026		027	
Item Name CT(Sn-61=0) VT(Sn-61=1)			CT	VT	CT	VT	CT	VT	CT	VT	CT	VT	CT	VT	CT	VT
			Inverter rated capacity (KVA)			2.2		3.4		4.1		7.5		10.3		12.3
Inverter rated current (A)			2.6		4		4.8		8.7		12		15		24	
Max. applicable capacity (HP) *2			1	1	2	2	3	3	5.4	7.5	7.5	10	10	15	15	20
Factory Setting	Cn-09	Motor rated current (A)	1.7	1.7	2.9	2.9	4	4	7.3	10.2	10.2	12.6	12.6	18.6	18.6	24.8
	Cn-12	Motor line impedance (Ω)	22.927	22.927	9.628	9.628	6.333	6.333	2.735	1.776	1.776	1.151	1.151	0.634	0.634	0.436
	Cn-13	Core loss torque compensation (W)	64	64	108	108	142	142	208	252	252	285	285	370	370	471
	Cn-34	Carrier freq. (kHz)	10	5	10	5	10	10	10	5	10	10	10	5	10	5
	Cn-37	Min. baseblock time (sec)	0.5	0.5	0.5	0.5	0.5	0.5	0.5	0.7	0.7	0.7	0.7	0.7	0.7	0.7
	Sn-02	V/F curve	01	07*1	01	07*1	01	07*1	01	07*1	01	07*1	01	07*1	01	07*1
Max. carrier freq. (kHz)			15	5	15	5	15	15	15	5	15	10	15	5	10	5

Sn-01 setting			028		029		030		031		032		033		034	
Item Name CT(Sn-61=0) VT(Sn-61=1)			CT	VT	CT	VT	CT	VT	CT	VT	CT	VT	CT	VT	CT	VT
			Inverter rated capacity (KVA)			27.4		34		41		54		68		82
Inverter rated current (A)			32		40		48		64		80		96		128	
Max. applicable capacity (HP) *2			20	25	25	30	30	30	40	50	50	50	60	75	75	100
Factory Setting	Cn-09	Motor rated current (A)	24.8	31.1	31.1	36.3	36.3	36.3	48.7	59.0	59.0	59.0	70.5	80.0	80.0	114
	Cn-12	Motor line impedance (Ω)	0.436	0.308	0.308	0.239	0.239	0.239	0.164	0.133	0.133	0.133	0.110	0.074	0.074	0.027
	Cn-13	Core loss torque compensation (W)	471	425	425	582	582	582	536	641	641	641	737	790	790	1800
	Cn-34	Carrier freq. (kHz)	10	5	10	5	10	10	10	5	10	10	10	5	10	5
	Cn-37	Min. baseblock time (sec)	0.7	0.7	1.0	1.0	1.0	1.0	1.0	1.0	1.0	1.0	1.0	1.0	1.0	1.0
	Sn-02	V/F curve	01	07*1	01	07*1	01	07*1	01	07*1	01	07*1	01	07*1	01	07*1
Max. carrier freq. (kHz)			10	5	10	5	10	10	10	5	10	10	10	5	10	5

Cont.

Table 9.2.3.1c 575V Class Inverter Capacity Selection

Sn-01 setting		051	052	053	054	055	056	
CT(Sn-61=0) VT(Sn-61=1)		CT	CT	CT	CT	CT	CT	
Item Name								
Inverter rated capacity (KVA)		1.7	3	4.2	6.6	9.9	12.2	
Inverter rated current (A)		1.7	3	4.2	6.6	9.9	12.2	
Max. applicable capacity (HP)		1	2	3	5.4	7.5	10	
Factory Setting	Cn-09	Motor rated current (A)	1.3	2.3	3.1	5.1	7.5	9.6
	Cn-12	Motor line impedance (Ω)	39.259	17.048	10.316	4.939	2.601	1.446
	Cn-13	Core loss torque compensation (W)	48	65	81	130	193	263
	Cn-34	Carrier freq.(kHz)	10	10	10	10	10	10
	Cn-37	Min. baseblock time (sec)	0.5	0.5	0.5	0.5	0.7	0.7
	Sn-02	V/F curve	01	01	01	01	01	01
Max. carrier freq. (kHz)		10	10	10	10	10	10	

*1 Use the variable torque patterns when there is a quadratic or cubic relationship between the speed and load, such as in fan or pump applications. The user can properly choose the desired (V/f) patterns (Sn-02=04, 05, 06, or 07) based upon the torque load characteristics.

*2 In fan or pump applications, the torque load has a quadratic or cubic relationship between the speed and load. The inverter capacity rating can be increased to a value that doubles its own specified capacity rating in some special cases. However, due to the real hardware limitation, 230V: 1HP, 2HP, 3HP, 10HP, 25HP, 40HP and 460V: 1HP, 2HP, 3HP, 30HP, 50HP can not be adapted to any larger capacity.

NOTES-

Sn-02 V/F curve selection (0 – 15)

- First set the inverter input voltage (Cn-01) to match the power supply voltage. Then using parameter Sn-02 the V / f curve can be set to any of the pre-set patterns 00 – 14 or can be customized by setting Sn-02 to 15.
- The following tables show the various Sn-02 patterns 0 -14

Table 9.2.3.2a V/F curve of 1 - 2 HP, 230V Class Inverter *

Specifications		Sn-02	V/F Pattern†	Specifications		Sn-02	V/F Pattern†		
General Purpose	50Hz	00		High Starting Torque‡	50Hz	08			
			09						
	60Hz	60Hz Saturation	01		60Hz	Low Starting Torque	10		
		50Hz Saturation	02			High Starting Torque	11		
	72Hz		03		Rated Output Operation (Machine Tool)	90Hz		12	
	Variable Torque Characteristic	50Hz	Variable Torque 1	04		120Hz	13		
Variable Torque 2			05						
60Hz		Variable Torque 3	06	180Hz	14				
		Variable Torque 4	07						

* These values are for the 230V class; double the values for 460V class inverters.

† Consider the following items as the conditions for selecting a V/f pattern.

- (1) The voltage and frequency characteristic of motor.
- (2) The maximum speed of motor.

‡ Select high starting torque only for the following conditions.

- (1) The power cable length is > 492ft (150m).
- (2) Voltage drop at startup is high.
- (3) An AC reactor is inserted at the input side or output side of the inverter.
- (4) A motor with a capacity smaller than the maximum applicable inverter capacity is used.

Cont.

Table 9.2.3.2a V/F curve of 3 - 40 HP, 230V Class Inverter *

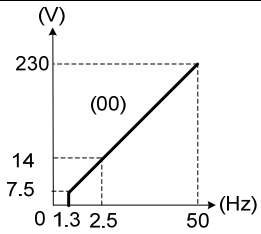
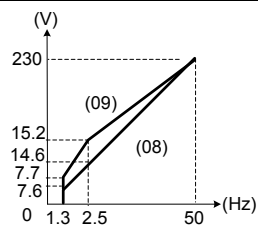
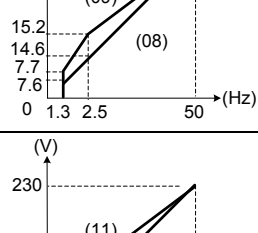
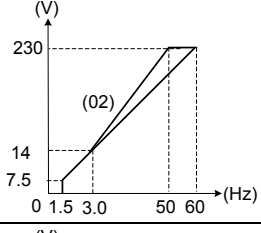
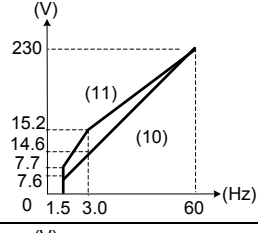
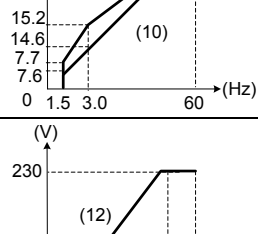
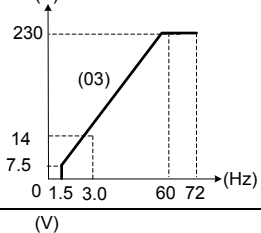
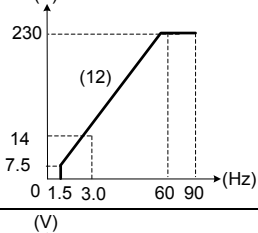
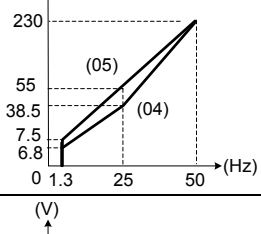
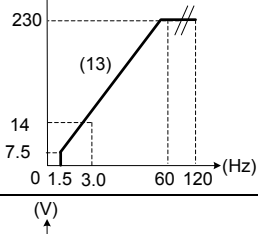
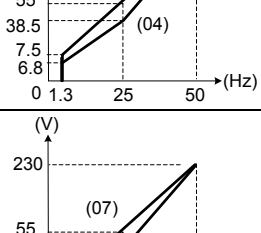
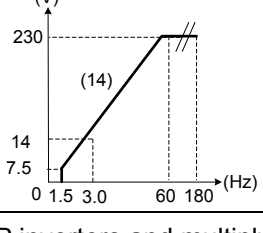
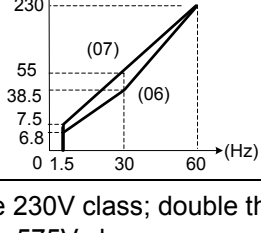
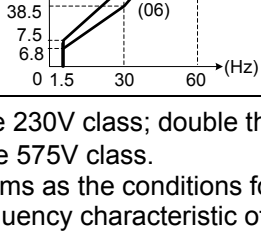
		Specifications	Sn-02	V/F Pattern†			Specifications	Sn-02	V/F Pattern†	
General Purpose	50Hz		00		High Starting Torque‡	50Hz	Low Starting Torque	08		
				High Starting Torque			09			
	60Hz	60Hz Saturation	01 15		High Starting Torque‡	60Hz	Low Starting Torque	10		
	50Hz Saturation	02								
	72Hz		03		Rated Output Operation (Machine Tool)	90Hz		12		
Variable Torque Characteristic	50Hz	Variable Torque 1	04			Rated Output Operation (Machine Tool)	120Hz		13	
		Variable Torque 2	05							
	60Hz	Variable Torque 3	06				180Hz		14	
		Variable Torque 4	07							

* These values are for the 230V class; double the values for 460V class 3~75HP inverters and multiply the value by 2.61 for the 575V class.

† Consider the following items as the conditions for selecting a V/f pattern.

- (1) The voltage and frequency characteristic of motor.
- (2) The maximum speed of motor.

‡ Select high starting torque only for the following conditions.

- (5) The power cable length is > 492ft (150m).
 - (6) Voltage drop at startup is high.
 - (7) An AC reactor is inserted at the input side or output side of the inverter.
- A motor with a capacity smaller than the maximum applicable inverter capacity is used.

Sn-03 Operator Display (0 – 12)

- Parameter code (Sn-03= 0 or 1)

Set the parameter Sn-03 to 0 or 1 to determine the access status of the following.

Sn-03	DRIVE Mode		PRGM Mode	
	Set	Read Only	Set	Read Only
0	An,Bn,P2, P4-05, P5	Sn,Cn,P1,P3, P4-01- 04	An,Bn,Sn,Cn, P1 - P5	-
1	An	Bn,Sn,Cn, P1- P5	An	Bn,Sn,Cn, P1- P5

- Setting Sn-03 = 7 – 12 (2 / 3 Wire operation):

- The setting of parameters Sn-03= 7-12 will set terminals ⑤ - ⑧ for 2-wire or 3-wire operation with the associated voltage. (See parameter summary)
- With the exception of parameters Sn-01-02 and Sn-61, the setting of parameter Sn-03 = 7-12 will Reinitialize some of the parameters within the groups, An-□□, Bn-□□, Cn-□□, Sn-□□ and P1-□□ - P5-□ to the factory default settings to the corresponding voltage.

 Caution	By setting Sn-03 = 7-12, some parameters are reset to factory default for the associated voltage. If these parameters had been previously set by the user the values will be lost.
--	--

- Parameters Sn-02 – 05 and 13-15 are reserved.

Sn-04 Run Source Selection (0 – 3)

- This parameter is used to select the source of run command.

Sn-04 = 0: digital operator

1: control circuit terminal

2: RS-485 communication

- By setting Sn-04 =1, the run source will be from the control circuit terminals and the run source function will depend on the setting of Sn-03 as follows.

Initial Setting	2-Wire Operation (Sn-03=7, 9 or 11)	3-Wire Operation (Sn-03=8, 10 or 12)
Run Source	FWD/STOP, REV/STOP	RUN, STOP, FWD/ REV.

Sn-05 Frequency Command Setting Method Selection

The parameter is used to select the source of frequency command.

Sn-05 = 0: digital operator

1: control circuit terminals

2: RS-485 communication

3: pulse input (See "pulse input setting" on [page 3-10](#))

Sn-06 Stopping Method Selection (0 – 3)

- Set the stopping method when a stop command is executed as follows.

Setting	Function
0	Deceleration to stop
1	Coast to stop
2	DC braking to stop: Stops faster than coast to stop, without regenerative operation.
3	Coast to stop with timer: Run sources are disregarded during decel. time.

Cont.

- The following diagrams show the operation of each stopping method.
 - a) Sn-06= 0 Deceleration to Stop
Deceleration to a stop at a rate set by the selected deceleration time.
 - b) Sn-06=1 Coast to Stop
After the stop command is executed, the run source is disregarded until the minimum baseblock time Cn-37 has elapsed.

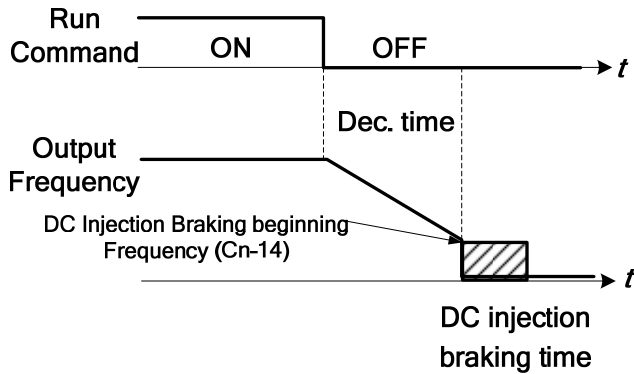

Fig. 9.2.3.1 Sn-06 = 0 Deceleration to Stop

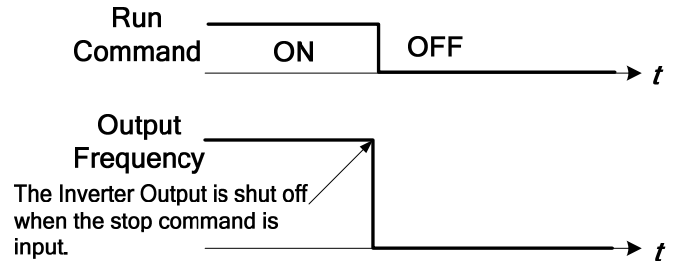

Fig. 9.2.3.2 Sn-06=1 Coast to Stop

- c) Sn-06=2 Whole Range DC Injection Braking to Stop

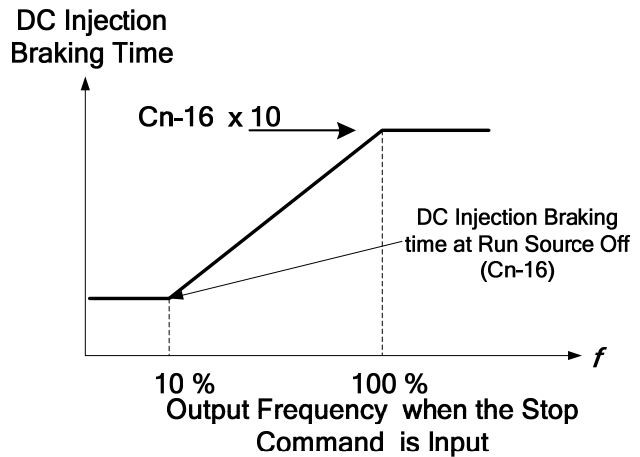
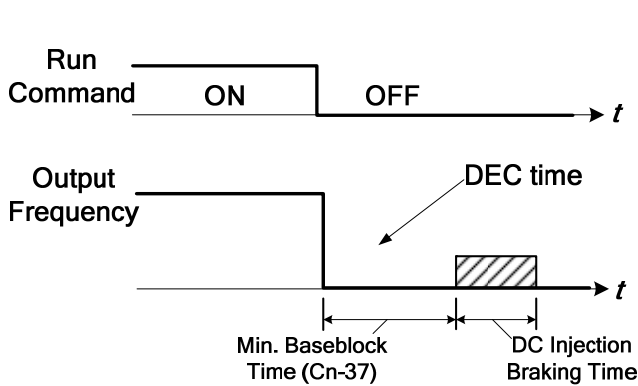

Fig. 9.2.3.3 Whole Range DC Injection Braking to Stop

- After the stop command is input and the minimum baseblock time (Cn-37) has elapsed, DC injection braking is applied and the motor stops.
- The DC injection braking time depends on the output frequency when the stop command is input and the setting of parameter Cn-16 (DC injection time at stop) is as shown in Fig.9.2.21.
- When the power applied to an induction motor is turned off, the counter-electromotive force generated by the residual magnetic field in the motor can cause an overcurrent to be detected when DC injection braking stop is applied. In this case, lengthen the minimum baseblock time (Cn-37) to prevent an overcurrent (OC) during stopping.

Cont.

d) Sn-06=3 Coast to Stop with Timer

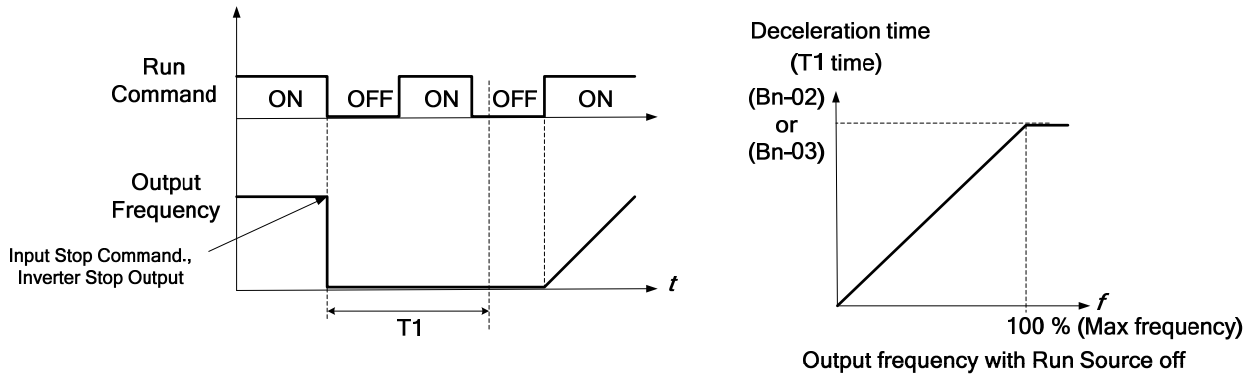

Fig. 9.2.3.4 Coast to Stop with Timer

After the stop command is executed, the run sources are disregarded until the time T1 has elapsed. The time T1 depends upon the output frequency when the stop command is executed and also on the deceleration time set by parameter (Bn-02 or Bn-04).

Sn-07 Stopping Priority (0 – 1)

This parameter enables or disables the STOP key on the digital operator when the run source is from the control terminals or from serial communication port while the motor is running.

Sn-07 = 0: Enabled. (The STOP key is enabled at all times during running.)

1: Disabled (The STOP key is disabled when the run source is from the control terminals or serial communication.)

Sn-08 Prohibition of Reverse Run

When the parameter Sn-08 is set to 1 reverse running of the motor is prohibited.

Sn-09 Output Frequency UP/DOWN Function (0 -1)

- The output frequency can be increased or decreased (UP/DOWN) using the digital operator.
 - Sn-09 = 0: The output frequency can be changed by pressing the UP / DOWN keys on the digital operator but will not be effective until the ENTER key is pressed.
 - 1: The output frequency can be changed by pressing the UP / DOWN keys on the digital operator without pressing the ENTER key.
- The output frequency can be changed (increasing (UP) or decreasing (DOWN)) through either the digital operator or the external multi-function input terminals (terminals ⑤ - ⑧).

Sn-10 Frequency Command Characteristics Selection (0 – 1)

Sn10=0 (For 30.16 software versions or earlier, set Sn-68= -0—) The positive and negative characteristics of the analog frequency command (0 - 10V / 4 - 20mA) is as per the following Fig. 9.2.3.5a.

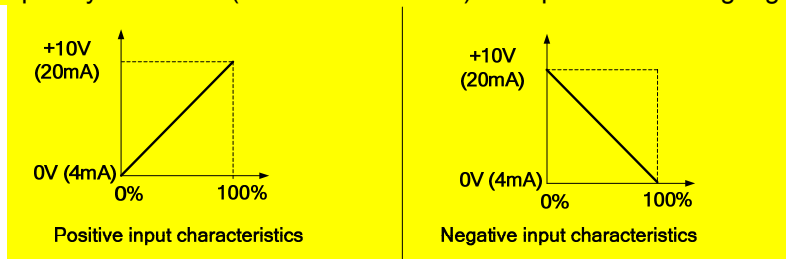

Fig. 9.2.3.5a Sn-10=0 Frequency Command Characteristics Selection

Cont.

Sn10=1 (For 30.16 software versions or earlier, set Sn-68= -1—) The positive and negative characteristics of the analog frequency command (-10 - +10V) is as per the following Fig. 9.2.3.5b.

Note- Only 230V: 3-40HP and 460V: 3-75HP inverters support an input of -10V - 10V analog voltage.

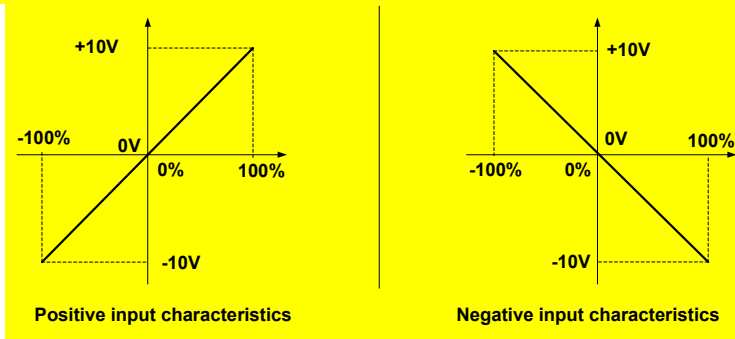

Fig. 9.2.3.5 b Sn-10=1 Frequency Command Characteristics Selection

Sn-11 Input Terminal Scan Time

This parameter sets the scan frequency of the input terminals.

- Sn-11= 0: Scan input terminals every 5ms.
- 1: Scan input terminals every 10ms.

Sn-12 Excess Load Detection Selection (0 – 4)

- When Excess Load Detection is enabled by Sn-12, parameters Cn-32 Excess Load Detection Level and Cn-33 Excess Load Detection Time must also be set.
- An excess load condition is detected when the Excess Load Detection is enabled, and the current exceeds the Excess Detection Level (Cn-32) longer than the Excess Load Detection Time (Cn-33).

Sn-12	Function	Display
0	Excess Load detection disabled	
1	Detect excess load only during speed agree. Continue operation after detection. (Minor fault)	"Excess Load Alarm" blinks
2	Detect excess load only during speed agree. Stop output after detection (Fault)	"Excess Load Fault" lights
3	Detect excess load at any time. Continue operation after detection. (Minor fault)	" Excess Load Alarm" blinks
4	Detect excess load at any time. Stop output after detection (Fault)	" Excess Load Fault" lights

Sn-13 Output Voltage Limit Selection (0 -1)

In the low speed region, if the output voltage from the V/f pattern is too high, a fault will result. As a result, the user can use this parameter to set the upper bound limit of output voltage.

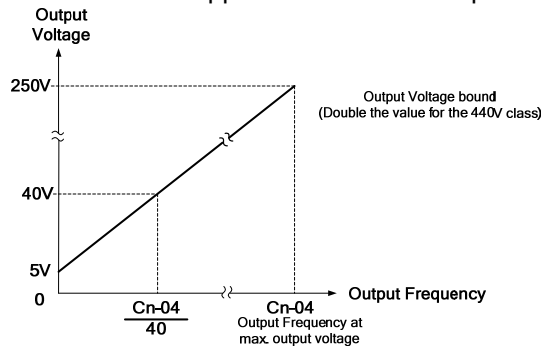

Fig. 9.2.3.6 Sn-13 Output Voltage Limit

Sn-14 Stall Prevention Selection During Acceleration (0 -1)

Sn-14= 0: Disabled (Accelerate according to the set rate. Stall may occurs with excessive loads.)

1: Enabled (Stop acceleration if the Cn-25 setting is exceeded. Accelerate again when current recovers)

Refer to “Stall prevention level during acceleration” on page [3-19](#).

Sn-15 Stall Prevention Selection During Acceleration (0 -1)

- If an external braking resistor unit is installed, Sn-15 must be disabled (Sn-15= 0).
- If no external braking resistor unit is installed, the inverter can provide about 20% regenerative braking torque. If the load inertia is large and it exceeds the regenerative braking torque, set parameter Sn-15 =1. When Sn-15= 1 (enabled), the deceleration time (Bn-02 or Bn-04) is extended so that a main circuit overvoltage does not occur.

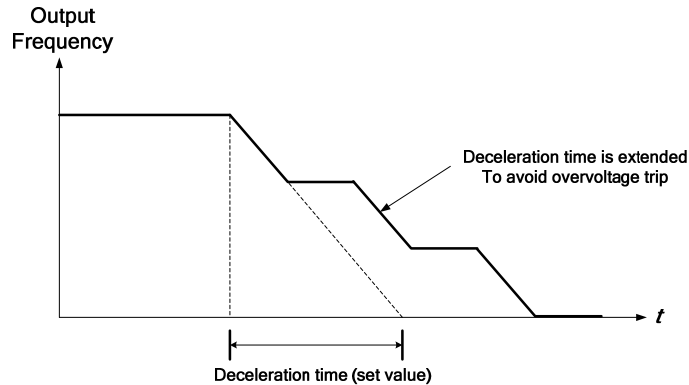

Fig. 9.2.3.7 Sn-15=1 Stall Prevention During Deceleration

Sn-16 Stall Prevention Selection during Running (0 – 1)

Sn-16= 0: Disabled (Stall can occur when a large load is applied)

1: Enabled (Deceleration will start if the motor current is larger than the stall prevention level during running and continues for more than 100ms. The motor is accelerated back to the reference frequency when the current falls below the level set by parameter Cn-26.)

Refer to “Stall prevention level during running” on [page 3-19](#).

Sn-17 Operation of output Fault Contact during Fault Retry (0 - 1)

Sn-17= 0: Do not output fault restart. (The fault contact does not activate)

1: Output fault restart. (The fault contact operates)

Refer to “Number of auto restart attempt” on page [3-18](#).

Sn-18 Operation Processing for momentary Power Loss (0 – 1)

- This parameter specifies the processing to be performed when a momentary power loss occurs (within 2 sec)
 - Sn-18= 0: When power loss ride-through is disabled Sn-18=0, the inverter will stop after a momentary power loss and an undervoltage fault will be detected.
 - 1: When power loss ride through is enabled Sn-18=1, the operation will be restarted after a speed search if the power is restored within the allowed time.
- If the power is interrupted for more than 2 seconds, the fault contact output will operate and the motor will coast to stop.

Sn-19 Zero Speed Braking Selection (0 – 1)

- When the run-source and frequency command is input from control circuit settings Sn-04=1 and Sn-05=1, If Sn-19 is enabled, the holding torque will be generated in DC-braking mode when the frequency command is 0V and forward-run source is on.
- A time-chart for the above action is shown in Fig. 9.2.26 below. The zero-braking selection Sn-19 is set to 1 and the DC-braking current Cn-15 is limited to within 20% of rated current.

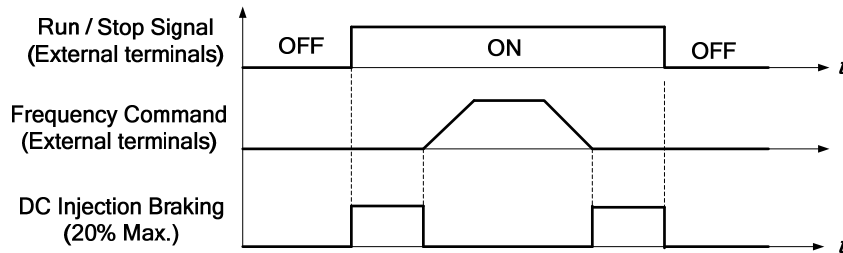
**Fig. 9.2.3.8 Zero Speed Braking Operation****Sn-20 External Fault Contact Selection (0 – 1)**

- Sn-20= 0: Input signal is from a normally open contact.
 1: Input signal is from a normal closed contact.

Sn-21 External Fault Contact Detection Selection (0 – 1)

- Sn-21= 0: Always detect.
 1: Detect only during running.

Sn-22 Detection Mode Selection of External Fault (0 – 3)

When an external fault is detected, the following operation will be performed based on the setting of Sn-22.

- Sn-22= 0: Decelerate to stop with the specified deceleration time of Bn-02.
 1: Coast to stop.
 2: Decelerate to stop with the specified deceleration time Bn-04.
 3: Continue running.

Sn-23 Motor Overload Protection Selection (0 – 4)

Sn-23 = 0: Electronic overload protection disabled.

When Sn-23=1- 4, the electronic overload protection is enabled. The electronic thermal overload is detected in accordance with the characteristic curves of operating time. vs. motor rated current setting (Cn-09).

- Sn-23=1: The overload is detected according to the standard motor cold start curve.
 2: The overload is detected according to the standard motor hot start curve.
 3: The overload is detected according to the specific motor cold start curve.
 4: The overload is detected according to the specific motor hot start curve.

- Set Sn-23=0 (Disable) when 2 or more motors are connected to a single inverter. An alternate method can be used to provide overload protection separately to each motor, such as connecting a thermal overload relay to the power line of each motor.
- The motor overload protection function should be set to Sn-23 = (2 or 4) (hot start protection characteristic curve) when the power supply is turned on and off frequently since the thermal values are reset each time the power is turned off.
- For a motor without a forced cooling fan, the heat dissipation capability is lower at low speed operation. In this case the setting for Sn-23 can be either (1 or 2).
- For a motor with a forced cooling fan, the heat dissipation capability is not dependent upon the rotating speed. Therefore, the setting Sn-23 can be either (3 or 4).
- To protect the motor from overload by the use of electronic overload protection, ensure that the parameter Cn-09 is set the rated current value shown on the motor nameplate.
- See Fig. 9.2.3.9.

Cont.

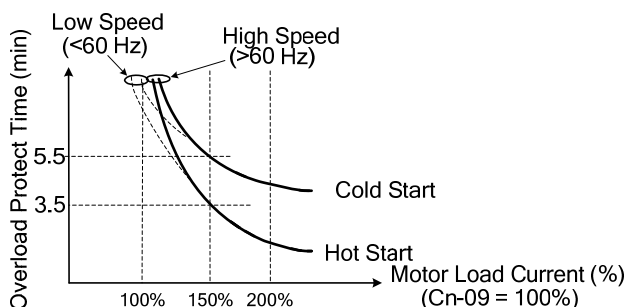

Fig. 9.2.3.9 Motor Overload Protection Curve (Cn-09=100%)

Sn-24 External Analog Input Frequency Characteristics Command Selection (0 -3)

Sn-24=0: Frequency command is from input VIN: 0 - 10V

1: Frequency command is from input AIN: 4 - 20mA

2: Frequency command is the sum of inputs (VIN + AIN). VIN: 0 - 10V and AIN: 4 - 20mA.

3: Frequency command is the difference of inputs (VIN - AIN). 0 - 10V and AIN: 4 - 20mA. If the value (VIN - AIN) is negative, the reference command will be 0.

- For inverters rated 230V: 3-40HP and 460V: 3-75HP, VIN accepts an input of ±10V if parameters Sn-68=-1— and Sn-05=1. Set Sn-24 to select the main frequency as follows:

Sn-24= 0: The frequency command is controlled by VIN (-10 - +10V).

(Corresponding command frequency: -10V - +10V → Reverse frequency 100% - forward frequency 100%)

1: The frequency command in controlled by AIN (4 - 20mA).

(The status of forward/ reverse is set by the user)

2: The frequency command is controlled by the sum of VIN and AIN.

3: The frequency command is controlled by the difference of VIN and AIN.

(When (VIN + AIN) < 0 or (VIN - AIN) < 0, main frequency switched to reverse status. When Sn-24 = 0, 2 or 3, forward or reverse is controlled by main the frequency command polarity.)

Sn-25 Multi-Function Input Terminal ⑤ Function Selection

Sn-26 Multi-Function Input Terminal ⑥ Function Selection

Sn-27 Multi-Function Input Terminal ⑦ Function Selection

Sn-28 Multi-Function Input Terminal ⑧ Function Selection

The settings and functions for the multi-function input are listed in Table 9.2.3.3.

Table 9.2.3.3 Multi-function Input Settings

Setting	Function	LCD Display	Description
00	Forward / Reverse command	3_Wire Run	3-wire operation mode
01	2-wire key-pressing input stop command	2_Wire Stop Key	2-wire operation mode
02	Multi-speed command 1	Multi-Fun. Command 1	Multi-speed frequency command selection
03	Multi-speed command 2	Multi-Fun. Command 2	
04	Multi-speed command 3	Multi-Fun. Command 3	
05	Multi-speed command 4	Multi-Fun. Command 4	
06	Jog	Jog Command	ON: Select jog frequency
07	Acc / Dec time switch command	Acc.& Dec. Switch	OFF: The first stage Acc / Dec time (Bn-01, Bn-02), ON: The second stage Acc / Dec time (Bn-03, Bn-04),
08	External base-block command (N.O. contact)	Ext.B.B. NO_Cont	ON: inverter output baseblock

Cont.

Table 9.2.3.3 Multi-function Input Settings *Cont.*

Setting	Function	LCD Display	Description
09	External base-block command (N.C. contact)	Ext.B.B. NC_Cont	OFF: inverter output baseblock
10	Inhibit Acc / Dec command	Inhibit Acc & Dec	Inhibit Acc / Dec (Hold frequency)
11	Inverter overheat warning	Over Heat Alarm	ON: Overheat indicator flashing (Inverter can proceed running)
12	FJOG	Forward Jog	ON: Forward jog
13	RJOG	Reverse Jog	ON: Reverse jog
14	PID integration reset	I_Time Reset	ON: Reset PID integration
15	PID control invalid	PID Invalid	ON: PID control not effective
16	External fault (N.O. contact)	Ext.Fault NO_Cont	ON: External fault input (normally open)
17	External fault (N. C. contact)	Ext.Fault NC_Cont	OFF: External fault input (normally closed)
18	Multi-function analog input	- Input Valid	ON: Multi-function analog input (AUX) effective
19	Timer function input	Timer Function	ON: ON-delay / OFF-delay timer input
20	DC braking command	DC Brakin Command	ON: DC injection braking applied when the frequency output is less than the DC injection start frequency
21	Speed search 1 command	Max Freq. Sp_Search	ON: Speed search is performed from max. output frequency
22	Speed search 2 command	Set Freq. Sp_Search	ON: Speed search is performed from reference frequency
23	Local / Remote control I	Operator Control	ON: Local mode control (through digital operator) OFF: Run Source and Frequency Command is determined according to (Sn-04, Sn-05) setting
24	Local / Remote control II	Ext. Term. Control	ON: Local mode control (control circuit terminal) OFF: Run Source and Frequency Command is determined according to (Sn-04, Sn-05) setting
25	RS-485 communication application	Comm. Control	PLC application extension use. (Please refer to "RS-485 MODBUS/PROFIBUS Application Manual")
26	speed control without PG	PG Invalid	ON: Speed control without PG
27	Reset integration of speed control with PG	I_Time Invalid	ON: Reset integration of speed control with PG
28	Frequency Up / Down function	UP / DOWN Function	Only Sn-28 can be set as Sn-28=28, terminal ⑦ used as up cmd. and terminal ⑧ used as down cmd. when Sn-28=28
29	Force operation signal	Force Run	Only Sn-28 can be set as Sn-28=29
30	PID control invalid 2	PID Invalid w An-16	See App-1 PID Application Note for further description.
31	External PID Invalid	Ext. PID Invalid	ON: The External PID is disabled
32	External PID Integrator Reset	Ext. I Time Reset	ON: The integration time is reset
33	PID Sleep	PID Sleep	ON: The sleep function is activated

Note: An error message of "Multi-Fun. Parameter" / "Setting Error" will be displayed if:
 1 - Setting combination of (Sn-25 - Sn28) is not organized in monotonically increasing order.
 2 - Setting 21, 22 (both for speed search command) are set at the same time.

Cont.

Sn-25-28=00 3-wire operation mode

When parameter Sn-03 = 8,10 or 12, 3-wire initialization mode, the multi-function input terminals ⑤-⑧ will be set for 3-wire operation. As shown in Fig.9.2.3.10, the Forward / Reverse control mode is set at terminal ⑤.

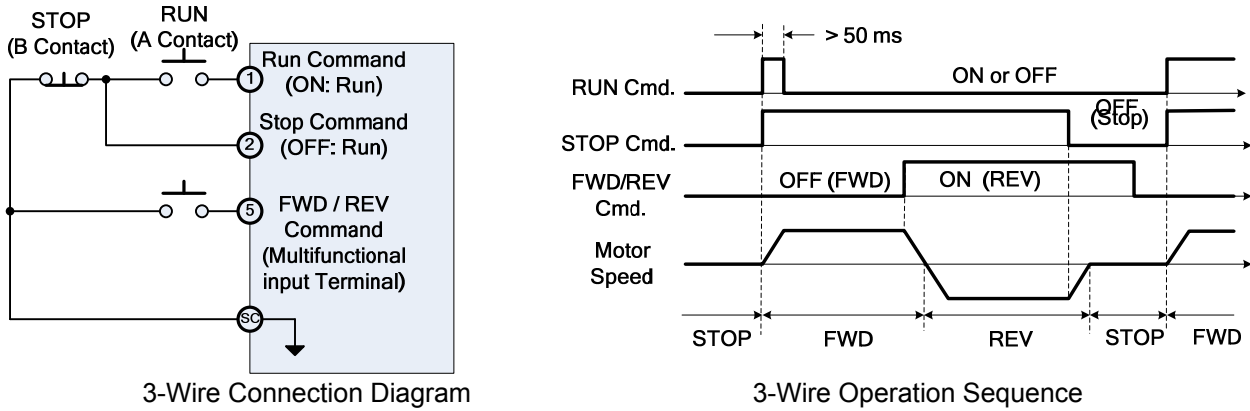

Fig. 9.2.3.10 3-Wire Operation (Sn-28=00)

Sn-25-28=01 Input STOP Command during 2-Wire Mode Operation

- The Stop command can be only set by parameter Sn-25 (Terminal ⑤).
- When initialized for standard 2-wire operation as shown in Fig. 9.2.3.11a, S1 and S2 can not be both ON at the same time. When S1= ON and S2= OFF, the motor runs FWD. When S1=OFF and S2= ON, the motor runs REV. When S1= OFF and S2= OFF, the motor Stops.
- When Sn-25= 01, the 2-wire operation mode has its self-sustaining function. Only through the multi-function input terminal ⑤ can the inverter can be stopped after pressing the STOP key as shown in Fig.9.2.3.11b. The switches S1, S2 and S3 are momentary switches. When S1 is pressed, the motor will run FWD. When S2 is pressed, the motor will run REV. When S3 is pressed, the motor will stop.

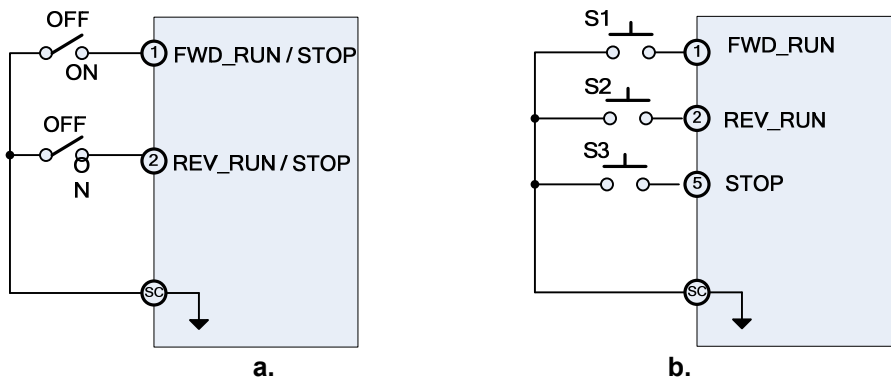

Fig. 9.2.3.11 2-Wire Operation

- Note:*
1. With the exception of Sn-28= 00 or 01, the external operation mode is defaulted to 2-wire operation and no self-sustaining function. i.e., the inverter will stop when the input contact at terminals ① and ② are not closed.
 2. In 2-wire mode, the error message “Freq. Comm. Error” will be displayed by the digital operator when terminals ① and ② are both ON at the same time, and the inverter will stop. When cleared, the inverter will return normal.

Cont.

- Sn-25=02** Multi-Step Speed Command 1
- Sn-26=03** Multi-Step Speed Command 2
- Sn-27=04** Multi-Step Speed Command 3
- Sn-28=05** Multi-Step Speed Command 4
- Sn-28=06** Jog Frequency Selection

- There are 16 (maximum) step speed command selections from the combination of the 4 Multi-Step Speed Commands and the jog frequency command.
- Multi-Step Speed command 1 - 4 and Jog Frequency Selection Setting Table 9.2.3.4.

Table 9.2.3.4

Terminal ⑧ (Sn-28= 05)	Terminal ⑦ (Sn-27= 04)	Terminal ⑥ (Sn-26= 03)	Terminal ⑤ (Sn-25= 02)	Selected Frequency
Multi-step Speed				
Cmd. 4	Cmd. 3	Cmd. 2	Cmd. 1	
0	0	0	0	Freq. Cmd. 1 (An-01) ^{*1}
0	0	0	1	Freq. Cmd. 2 (An-02) ^{*2}
0	0	1	0	Freq. Cmd. 3 (An-03)
0	0	1	1	Freq. Cmd. 4 (An-04)
0	1	0	0	Freq. Cmd. 5 (An-05)
0	1	0	1	Freq. Cmd. 6 (An-06)
0	1	1	0	Freq. Cmd. 7 (An-07)
0	1	1	1	Freq. Cmd. 8 (An-08)
1	1	1	1	Freq. Cmd. 16 (An-16)

0: terminal is OFF; 1: terminal is ON

- The example shown in Fig. 9.2.3.12 below shows the operation sequence of a multi-step speed and jog command.

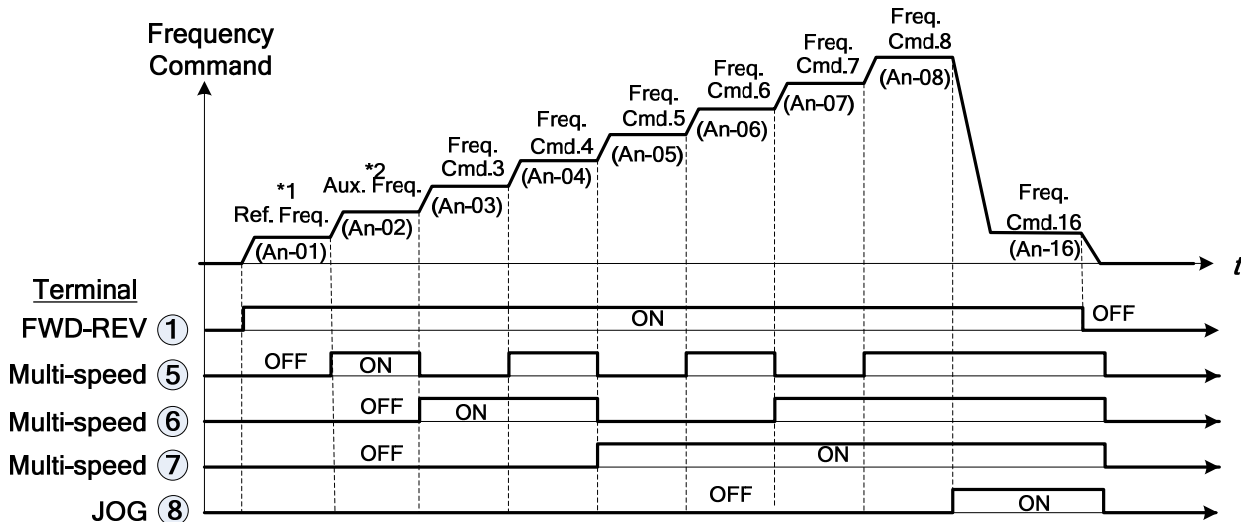

Fig. 9.2.3.12 Timing Chart for Multi-Step Speed and Jog Command

- *1 When parameter Sn-05=0, the frequency reference command is set by An-01. When Sn-05= 1, the reference command is input from the analog terminals VIN and AIN.
 - *2 If parameter Sn-29= 0, the auxiliary frequency (the 2nd step frequency setting: AUX frequency) is input from the AUX terminal. If the parameter Sn-29 ≠ 0, the 2nd step frequency setting is determined by parameter An-02.
- Cont.*

Sn-25-28=07 Acceleration Time And Deceleration Time Change

The acceleration time and deceleration time can be changed through the control terminals ⑤-⑧ as described on [page 3-4](#).

Sn-25-28=08 External Baseblock (N.O. Contact)

Sn-25-28 =09 External Baseblock (N.C. Contact)

- Either of these settings will control inverter baseblock operation, through the multi-function input terminals.
- During running when an external baseblock signal is detected, the digital operator will display “B.B. Alarm” and the inverter output is blocked. After the baseblock signal is cleared, the motor will resume operation.
- During deceleration, when an external baseblock signal is input, the digital operator will display “ B.B. Alarm” and the inverter output is blocked and the output frequency will drop to zero. The motor will then coast to stop freely. After the external baseblock signal is cleared, the inverter will remain in the stop mode.

Sn-25-28=10 Acceleration and Deceleration Ramp Hold

This setting will pause the acceleration or deceleration of the motor and maintain the current output frequency. The motor will coast to stop if an OFF command is input while the acceleration / deceleration ramp hold input is ON and the current output frequency will be stored. When the ramp hold signal is released the acceleration / deceleration ramp will resume at the stored frequency. (See Fig. 9.2.3.13 below)

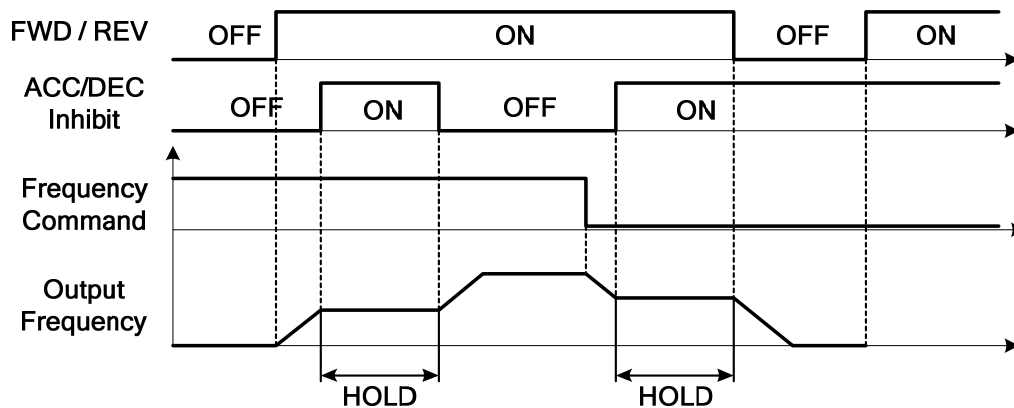

Fig. 9.2.3.13 Acceleration and Deceleration Ramp Hold

Sn-25-28=11 Inverter Overheat Alarm

When the inverter detects a overheat signal, the digital operator will display “Overheat Alarm”. and the inverter will maintain normal operation. When the overheat signal is OFF, the digital operator will return to its previous display automatically. No RESET is required.

Sn-25-28=12 FJOG Command

Sn-25-28=13 RJOG Command

- Jogging can be performed in forward or reverse direction.
Setting: 12 - FJOG command ON run forward at the jog frequency set by An-17.
13 - RJOG command ON run reverse at the jog frequency set by An-17.
- The forward and reverse jog commands have priority over other frequency commands.
- The inverter will stop running in accordance the setting of Sn-06, if the forward jog and reverse jog commands are both ON for more than 500 ms.

Sn-25-28=14 PID Integral Reset

Sn-25-28=15 PID Control Invalid

See "APP-1 PID Application Note" for a description.

Sn-25-28=16 External Fault N.O. Contact

Sn-25-28=17 External Fault N.C. Contact

- When the external fault input terminal is ON, an external fault is detected. If external input terminal ⑥ is set for an external fault, a message “Fault Ext. Fault 6” will be displayed.
- There are 5 terminals that can assigned as external fault inputs, they are terminals ③, ⑤, ⑥, ⑦, ⑧.
- When an external fault occurs, the inverter will be blocked from output and the motor will coast to stop.

Cont.

Sn-25-28=18 Multi-Function Analog Input Setting

The multi-function analog input at the AUX terminal can be enabled or disabled by an external signal. When the PID function is enabled, the AUX function will be disabled.

Sn-25-28=19 Timer Function Input Terminal

Refer to the setting of the timer function output terminal on page 3-63

Sn-25-28=20 DC Injection Braking Command

- DC injection braking is used to prevent the motor from rotating due to inertia or external forces when the inverter is stopped.
- When the DC injection braking signal is ON, the motor will stop. If a run source or jog command is input, the DC injection braking will be cleared and the motor will begin to run. (See Fig. 9.2.3.14 below)

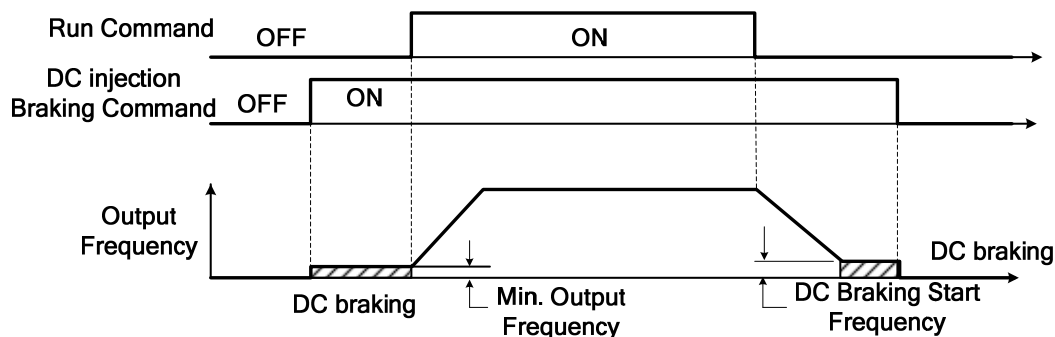

Fig. 9.2.3.14 Time chart for DC injection braking command

Sn-25-28=21 Speed Search 1

Sn-25-28=22 Speed Search 2

Refer to 'speed search' function on page 3-23.

Sn-25-28=23 LOCAL/REMOTE Control 1

OFF	Remote Control: The Run command and Frequency command is performed through the control terminal inputs or the RS-485 communication port. It is set by the combination of settings of parameters Sn-04 and Sn-05. The REMOTE-REF and the SEQ LED's are ON.
ON	Local Control: The Run and Frequency commands are performed through digital operator. The REMOTE-REF and SEQ LED's are OFF.

The LOCAL to REMOTE mode can only be changed when the inverter is in the STOP mode.

Sn-25-28=24 LOCAL/REMOTE Control 2

OFF	Remote Control: The Run command and Frequency command is performed through the control terminal inputs or the RS-485 communication port. It is set by the combination of settings of parameters Sn-04 and Sn-05. The REMOTE-REF and the SEQ LED's are ON.
ON	Local Control: The Run command and Frequency commands are performed through control circuit terminals. The REMOTE-REF and SEQ LED's are OFF.

The LOCAL to REMOTE mode can only be changed when the inverter is in the STOP mode.

Sn-25-28=25 RS-485 Communication Application

The multi-function input terminals ⑤ - ⑧ can be used as the extension contact terminals of a PLC with the command communicated through the RS-485 port. (Refer to the "RS-485 MODBUS/PROFIBUS APPLICATION MANUAL" for further information)

Cont.

Sn-25-28=26 Speed Control Action without PG

Sn-25-28=27 Reset Integration of Speed Control with PG

When PG feedback is used, the integral control (used with PG feedback compensation) can be disabled or enabled from the external control terminals. The external terminals can also be used to clear the integral value. (See Fig. 9.2.3.15 below)

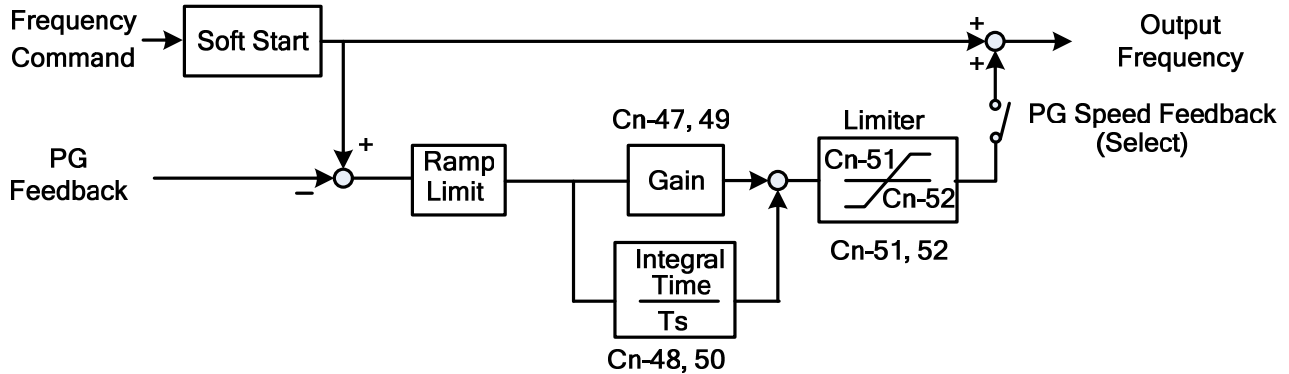

Fig. 9.2.3.15 PG Speed Control Block Diagram

Sn-25-28=28 Frequency UP/DOWN Function

- The output frequency can be changed up or down using either the digital operator or the external multi-function input terminals (⑦ or ⑧).
- By setting parameters Sn-04=1 and Sn-05=1, the run source and frequency command is set through the control circuit terminals. By setting parameter Sn-28=28, terminal ⑦ will now have the UP function and its original function is disabled. Terminals ⑦ and ⑧ can now be used for the UP / DOWN function to control or change the output frequency.
- The Operation sequence is as shown below:

Control circuit terminal ⑦: UP function	ON	OFF	OFF	ON
Control circuit terminal ⑧: DOWN function	OFF	ON	OFF	ON
Operation status	ACC (UP)	DEC (DOWN)	Constant (HOLD)	Constant (HOLD)

- See Fig. 9.2.3.16 below.

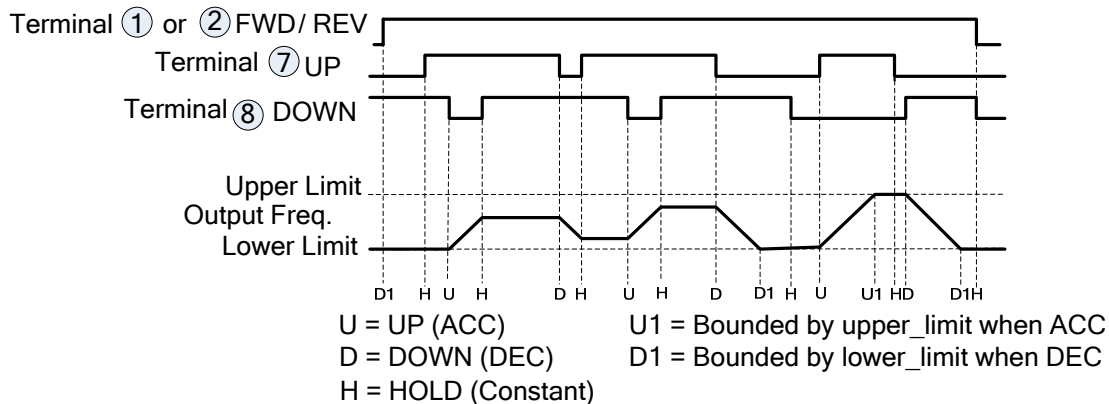

Fig. 9.2.3.16 Time Chart of Output Frequency with UP/DOWN Function

Cont.

- UP/DOWN operation can only be set through parameter Sn-28.
- When the frequency UP/DOWN function is being used, the output frequency will accelerate to the lower_limit set by Cn-19 when a run command is activated.
- If in a HOLD state, and the 4th bit of Sn-68 is set to 1, the value of the output frequency will be stored when the power is off. When power is restored and a Run command is given, the inverter will run at the stored output frequency.
- Under auto operation mode, the UP/DOWN function will not operate.
- When the UP/DOWN function and jog frequency command are both assigned to multi-function inputs, the jog frequency command input has the highest priority.
- With UP/DOWN operation, both the PID and Multi-Step Speed Commands are unavailable.

Sn-25-28=29 Forced Run

- Forced Run can only be set through parameter Sn-28=28. It is for special use (smoke fan, etc.)
- The inverter will ignore the fault or alarm and the PID function will be disabled if the Forced Run input is ON.
- If the Forced Run input is ON and RUN command is ON, the inverter will run at maximum frequency set by parameter Cn-02 and the frequency command becomes invalid.

Sn-25-28=30 PID control invalid 2**Sn-25-28=31** External PID Invalid**Sn-25-28=32** External PID Integrator Reset**Sn-25-28=33** PID Sleep**Sn-29** Multi-Function Analog Input Function Selection

- The settings and functions for the multi-function analog input (Terminal AUX) are listed in Table 9.2.3.5.

Table 9.2.3.5 Multi-function Analog Input Functions

Setting	Function	LCD Display	Description (100% output corresponds to 10 V level)
00	Auxiliary frequency command	Auxiliary Freq.Cmd.	(Max. output frequency)
01	Frequency command gain (FGAIN)	Instruction gain 1	Total gain = (Bn-05, Bn-07) × FGAIN
02	Frequency command bias 1 (FBIAS1)	Cmd. Bias 1	Total bias = (Bn-06, Bn-08) + FBIAS1
03	Frequency command bias 2 (FBIAS2)	Cmd. Bias 2	Total bias = (Bn-06, Bn-08) + FBIAS2
04	Excess Load Level	Excess Load Level	According to analog input voltage (0-10V), change excess load level (setting of Cn-32 is disabled)
04	Overtorque detection level	Over Tq. Level	According to analog input voltage (0-10V), change overtorque detection level (setting of Cn-32 is disabled)
05	Output frequency bias (VBIAS)	Output Voltage	Total output voltage= V/F pattern voltage + VBIAS
06	Scaling of ACC/DEC time(TK)	Acc&Dec Coeff	Real ACC/DEC time= ACC/DEC time (Bn-0 to24) / TK

Cont.

Table 9.2.3.5 Multi-function Analog Input Functions (Cont.)

Setting	Function	LCD Display	Description (100% output corresponds to 10 V level)
07	DC injection braking	DC Brakin current	According to analog input voltage (0-10V), change the level of DC injection current (0-100%). (inverter rated current=100%, the setting of DC injection current Cn-15 is disabled)
08	Stall prevention level during running	Run Still Level	According to analog input voltage (1.5V-10V), change the level of stall prevention during running (30%-200%) (inverter rated current=100%, the setting Cn-26 is disabled.)
09	PID control reference input	PID Command	Multi-function analog input (terminal AUX) used as PID control reference input (0-10V). Refer to App-1 PID Application Note.
10	Frequency command lower limit	Freq. Cmd. Low Bound	Changes the frequency command lower-limit (0-100%) value according to the then analog input voltage (0-10V) (Max. output frequency (Cn-02) corresponds to the 100% analog output. The actual lower-limit is determined by the maximum value of Cn-19 and the value corresponding to the multi-function analog input terminal).
11	Jump frequency setting4	Freq Jump 4	Sets the jump frequency 4, according to analog input voltage (0-10V), while Cn-20 to Cn-23 can be used to set the jump frequency 1-3 and their jump frequency width.
12	RS-485 communication application	Comm. Control	The analog value of AUX 0 – 10V can be read through serial communication (RS485). The scaling is (0 -10V = 0 – 1024)
13	Frequency instruction gain 2 (FGAIN)	Instruction gain2	With Bn-05, 06 (or Bn-07, 08) set, adjust analog frequency instruction gain and bias (gain and bias adjustment is similar to 7200GA)
14	Frequency instruction bias 3 (FBIAS1)	Instruction bias 3	?
15	Frequency instruction bias 4 (FBIAS2)	Instruction bias 4	?
16	Load Loss Level	Load Loss Level	?
17	Flow Meter	Flow Meter	?
18	External PID Set Point	Ext. PID Set Point	?
19	External PID Feedback	Ext. PID Feedback	?

- The AUX analog input can provide two groups of gain and bias; Sn-29 =1-3 and Sn-29=13-15. When Sn-29=13-15, the adjustment of gain and bias is similar to the **GA series**. (See Fig. 9.2.3.17)



Fig. 9.2.3.17 Gain and Bias

- The following Fig. 9.2.3.18 shows the multi – function analog input characteristics.

Cont.

