

Contents

Precautions of the safe operation	3
1、Check and accept	4
1-1、check	4
2、Installation	5
2-1、demount and remount front cover.....	5
2-2、Take down and reinstall numeric keypad.....	6
2-3、Select the place to install the inverter.....	6
2-4、The installation space to choose.....	7
3、Wiring	8
3-1、Perphearl device and wiring the arbitrary option.....	9
3-2、wiring diagram.....	10
3-3、Wiring of main loop.....	12
3-4、Grounding	16
3-5、Wiring of control circuit.....	17
3-6、wire check.....	19
4、Operation	19
4-1、Select the operation mode	19
4-2、The check before test operation.....	20
4-3、trial operation.....	20
4-4、Operating check.....	21
5、front panel operation	21
5-1、front panel function.....	21
5-2、The display mode of inverter.....	23
5-3、The step of setting data.....	25
5-4、The supervision step of data operation.....	25
6、The function description	27
6-1、Prepare for setting parameter.....	27
6-2、The basic parameter setting.....	28
6-3、Operating order.....	33
6-4、Output function.....	34
6-5、Input function.....	39
6-6、Multiple speed & process operation.....	44

6-7、PI controlling parameter.....	50
6-8、Protection parameter.....	51
6-9、Other function.....	57
6-10、RS-485 control.....	59
7、 Failure recovery.....	61
7-1 Faulty diagnose and correction measure.....	62
7-2 Warning display and explain.....	63
7-3 The motor faulty and correction measure.....	64
8、 Quality Guarantees.....	66
Appendix1 technical norm.....	68
Appendix2 function parameter catalog.....	70
Appendix3 shape dimension.....	84
Appendix4 kinds of rating output amperemeter type.....	85
Appendix5 routine maintenance and check.....	88
Appendix6 RS-485 communication agreement.....	91
Appendix7 auxiliary instrction for CS3200 series inverter in use to Injection machine reforming	94
9、 Option.....	97

Notice transaction for safe operating

Before installation, operation, maintenance or checking should read the instruction carefully

The notice transaction about safe operation can be classified to “warning” or “attention”



Warning

While in potential dangerous state, if not to abstain, might result in personal injury or loss of life.



Caution

While in potential dangerous state, if not to abstain, might lead to gently or moderate body hurt and device breakage. It can be used to guard for unsafe operation.

In some case, even in the “Caution” content will lead to heavy accident. so, in any case you should observe the important transaction.

Attention

: the adopting step for insure the accurate operation.



Warning

- While installing or operating, should observe the guidance of instruction
- Verify the inverter rating voltage should be consistent with the AC power supply voltage
Not to observe the warning, might lead to injury or catch fire
- Do not make AC loop supply power and output terminal U, V and W connected.
While in connecting, the inverter will be damaged, and maintenance bond will be invalidated
- Only after install the panel can connect the input power supply, while electrified, don't remove the outside cover.
If not observe might lead to electric shock
- Do not touch the high pressure terminal inside the inverter
If not observe might lead to electric shock
- After break the main loop power supply, only finish affirmed can maintenance and check Capacitor inside machine with charge, is very dangerous, should wait at least 5 minutes, till finished discharge of the DC bus bar capacitor.
- While electricity do not connect or break the guide line and the connection
If not observe will lead to body injured.
- Controlling PCB panel should use CMOS ICS, do not touch CMOS element
CMOS element is easy to be disturbed with static
- The inverter can not be in pressurization test.

It could cause the damage of the inverter inner semiconductor component

1、 Check and accept

 Caution
<p>●Do not install and operate the inverter which has been damaged or has the blunder component otherwise it will hurt person or destroy the facility.</p>

This chapter introduces the check method of the inverter used by the user.

1-1、 check

1-1-1、

This table is check item

Check item	Explain
Does the inverter type agree with the indent	Check the type in flank data plate of the inverter.
Does this have the damage of the component?	Check the appearance by eyeballing and assure no damage while transiting
Is the component screw up safely or not	Take off the front cover of the inverter. use the suitable tool to check the entire eyeable component.
Receive the instruction or not? Receive the certificate of qualification and maintenance card	Instruction certificate of qualification and maintenance of inverter

If do not satisfied with any check item above. please contact with our company.

1-1-2、 Check the dataplate data

Dataplate data

Take the CS3200-G1R5T4 for example

Specification

Input specification

Output specification

Lot identification mark

MODEL: CS3200-G1R5 T4
INPUT: AC 3PH 380V ±15% 50/60Hz
OUTPUT: AC 3PH 0-380V 0-300HZ 3.7A
SER NO:  7 6 5 4 3 2 1 0 A 2 1 R 5 G

Data dataplate

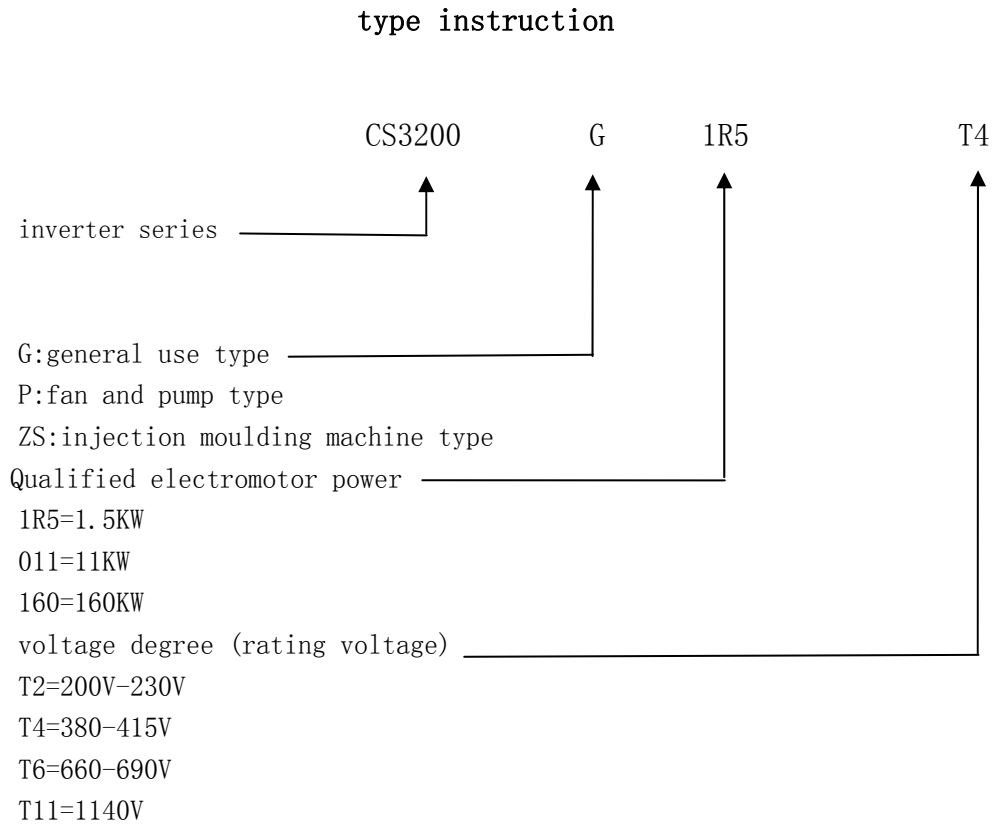

2、Installation

Caution

- Stock bed lift the machine, do not take front cover lift when move the inverter otherwise main body may drop out cause damage.
- Please install the inverter in the unflammable material. (like metal)
If do not abide the warning may cause fire alarm.
- when put the setting into the ark, can install a fan or other cooling facility, at the same time assure the air entrance temperature under 45°C.
Overheat will burn or setting damage.

This chapter introduce the formation and setting environment and space while install the CS3200 series inverter.

2-1、demount and remount the front cover

Ecumenic install, it' s no need to take off the front cover and numeric keypad. The keypad contact with the inner circuit with the electric cable. When loading and unloading must be careful. Pull out the electric cable first then take down the keypad and front plat, or may make the plug damaged.

2-2、 Take down and reinstall numeric keypad

Take down and reinstall the numeric keypad use the methods blew:

- Take down the numeric keypad.

Press the locked clasp of the pressing numeric keypad, can take out the numeric keypad from the front cover.

- Reinstall the numeric keypad.

Press the numeric keypad on the frame of the panel front panel frame. The locked clasp will lock the numeric keypad itself.

2-3、 choose the environment to install the inverter

Assure the complete performance and the life for using, when choose install the CS3200 series inverter environment may obey the suggestions below.

- ★ Avoid meet the sunlight directly. Do not use in the open air directly.
- ★ Do not use in the corrosive gas and liquid environment.
- ★ Do not use in the oil fog and splash environment .
- ★ Do not use in the salt-fog environment.
- ★ Do not use in the aquosity and rain environment.
- ★ Install the filter unit when there are some metal powder and silk fribe in the air.
- ★ Cannot use in the machine strike and librate situation.
- ★ Must take reduce temperture measure, when the using environment is over 45°C.
- ★ Too cool and hot will make the setting fault. the suggestion temperture range is -10°C ~ 40°C
- ★ Far from the power supply yawp. Such as the electric welder and the large power facility.
- ★ Radioactivety material can effect the use of the facility.
- ★ Tinderbox, thinner and solvent may be far away from the facil

2-4、The installation space to chose

CS3200 series inverter should have enough radiating space for cooling when install vertically.

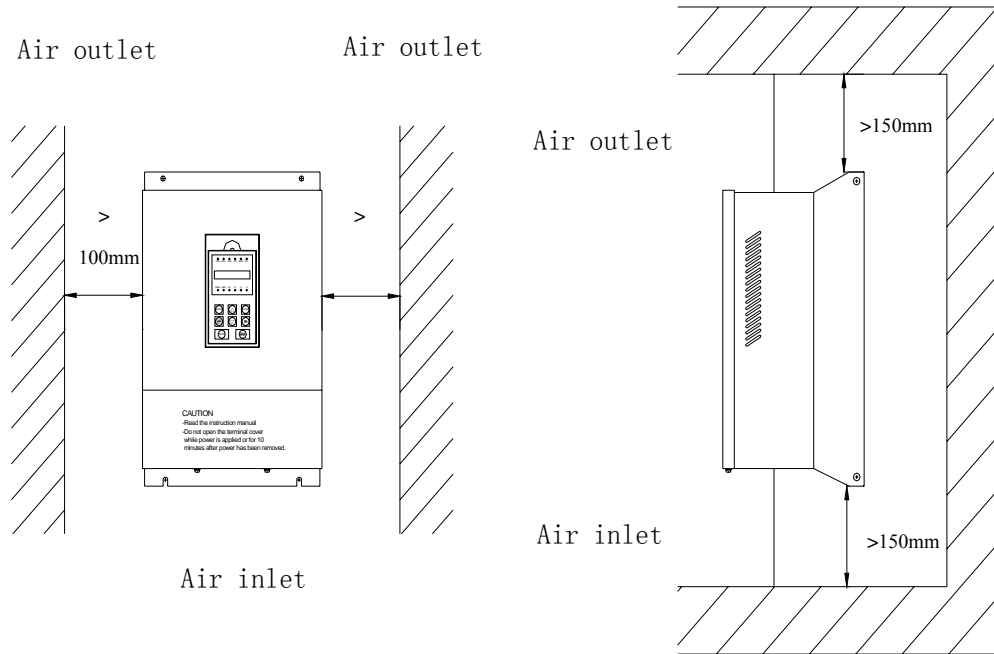



CS3200 series inverter installation space

★ **notice**

- 1、The space needed by the top/button and the both sides are the same for the open framework type (IP00) and the close hang type (IP55).
- 2、The admission entering air temperature for the inverter are:
open framework type: $-10^{\circ}\text{C} - +45^{\circ}\text{C}$
close hang type: $-10^{\circ}\text{C} - +40^{\circ}\text{C}$
- 2、The top and underpart area should leave enough heat dissipation space; in order to pass in and out the frequency inverter air can be unobstructed.

3、Wiring

 Warning
<ul style="list-style-type: none"> ● Only after affirming the power supply be turned off can be connected. If not abide the warning will lead to electric attack or catch fire. ● Specialty personnel can only make the connection. If not abide the warning will lead to electric attack or catch fire. ● While the loop linking stopped urgency , after connected needs to check the action. If not abide the warning will lead to body injured ● All the down-lead pressurization shoud as same grade as the converser voltage. If not abide the warning will lead to body injured

 Caution
<ul style="list-style-type: none"> ● Verify the inverter rating voltage should be consistented with the AC power supply voltage If not abide the warning will lead to body injured or catch fire. ● The inverter can mot be in pressurization test. Otherwise, will lead to the damage of the semiconductor element. ● To screw down the terminal bolt with the appointed torque. Do not obey this may cause the damage of the facility.

This charper introduce CS3200 series inverter' s wiring of main loop and control circuit.

Main loop terminal.

	Power supply	Single-phase 220v Three-phase 380v 50/60Hz
Input	Admission	voltage: +10~-15% (brevity fluctuate±15%)
	fluctuate	frequency: ±5%

Less than 18.5KW standard:

R	S	T	P+	N-	B	E	U	V	W
---	---	---	----	----	---	---	---	---	---

18.5KW-75KW standard:

R	S	T	P+	N-	E	U	V	W
---	---	---	----	----	---	---	---	---

93KW-132KW standard:

R	S	T	P1	P+	N-	E	U	V	W
---	---	---	----	----	----	---	---	---	---

above 160KW standard:

P+	R	S	T		U	V	W	N-
----	---	---	---	---	---	---	---	----

sign	function
R	AC Power supply input
S	Single-phase or three-phase 200 - 230V AC (220V unit), three-phase 380-460V AC (400V unit)
T	
U	Three-phase output terminal connecting the machine
V	
W	
P+	Positive DC generator terminal
P1	DC generator reactor connecting terminal (between P+)
B	dynamic brake resistance connecting terminal (between P+)
N-	Negative DC generator terminal
E	Chassis grounding (according to different types, the grounding terminal can be on the radiator not always on the terminal line.)

3-1、Periphery device and wiring the arbitrary option

Here is the standard connecting method for CS3200 rounding machine.

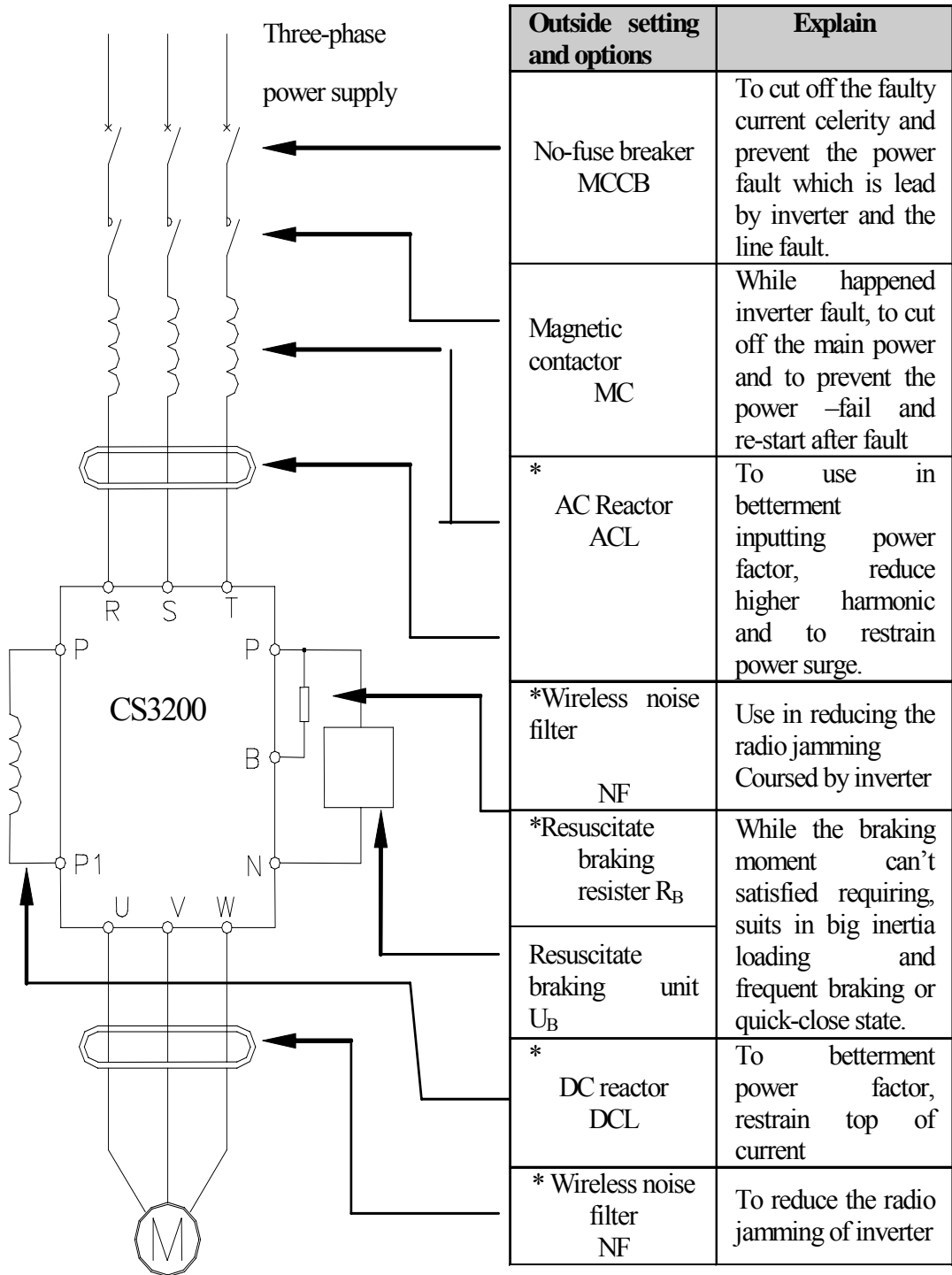

Note : the “*” marks means the options.

3-2、Wiring diagram

The wiring diagram of main loop and controlling loop is shown in the below.while to use numeric keypad, the motor will run as long as connect the main loop.

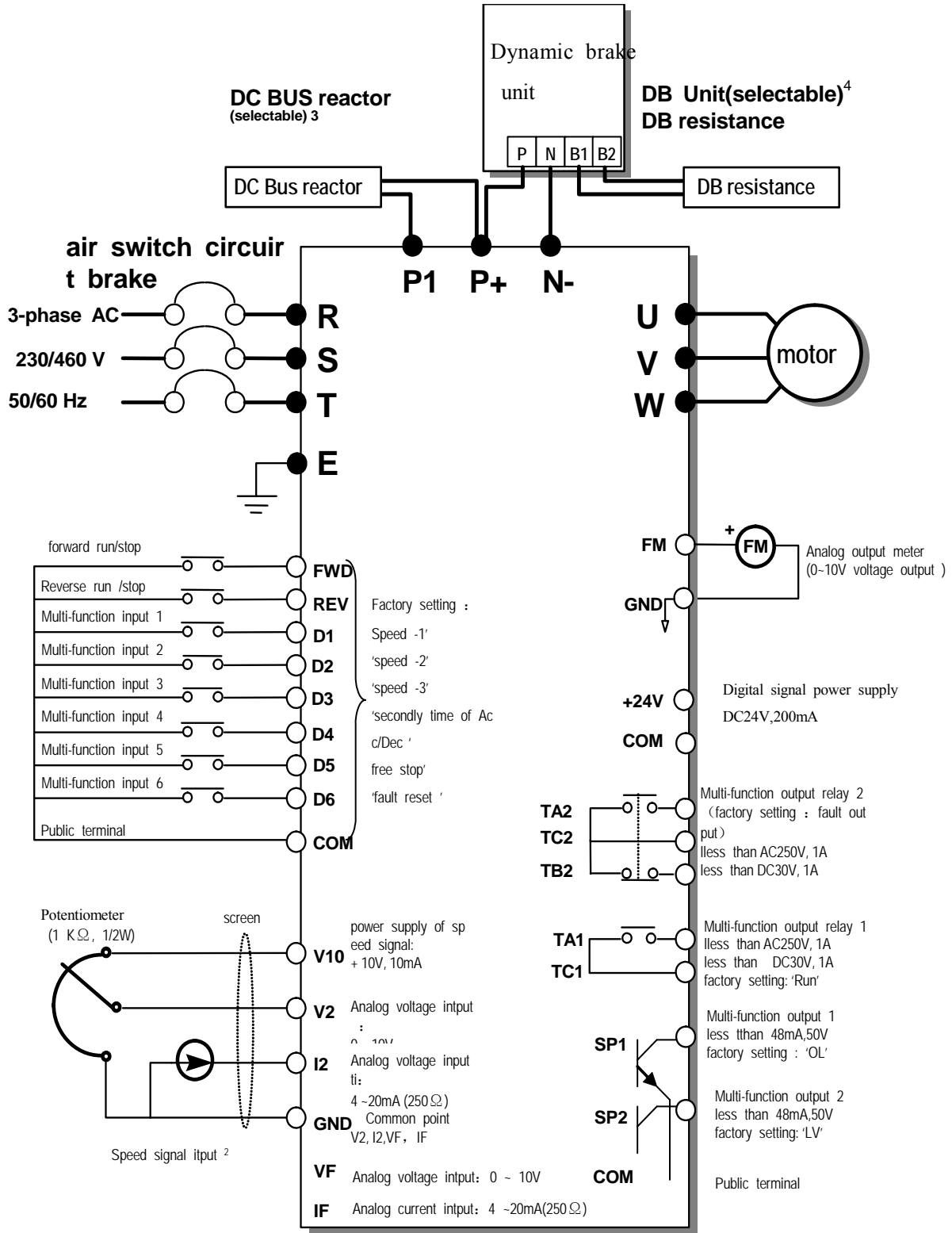

(note) ● display main loop terminal ○display controlling signal terminal

1. According to the difference of the mode's name, the terminal structure is different, please refer to read "power terminal"
2. Analog speed order can be set by voltage, or by current.
3. While install DC reactor, the public conductor which between P1 and P+ should be concealed (short-circuit Cu-line)
4. 0.75KW ~15 kW inverter will brake the circuit on the circuit board, and the braking resistance should be within the 0.75KW ~7.5 kW inverter. The inverter which is above 11kW can dynamic braking with braking unit and the resistance.

* V2, I2 can not input at the same time , VF, IF can not input at the same time ,

★ Attention

1. Control connector, frequency setting and scout instrument request to use screening line or twin screening lines.
2. The input voltage or current which is afforded to the basic frequency can be choosed by constant 01-01.
3. The most output current of control circuit connector VIO is 50mA
4. The output multi-function analogy quantity is used to scout screening (For example the output frequency meter, ammeter), but it can not be used to feedback control system.

3-3、Wiring of the main loop

 **Warning**

The safty grouding connector has been put to earth.

The 200V rank grouding connection resistance:100 ohm or less

The 400V rank grouding connection resistance:10ohm or less

The 660V rank grouding connection resistance:5ohm or less

If not obey to the warning, it causes electric shock or fire

 **Caution**

**Do not made AC loop supply power and output terminal
U, V and W connected.**

The main circuit input side connection matters need attention

(a)The installation of breaker (MCCB)

In order to protect the line, it must connect the MCCB or the protector to the AC main Circuit current and CS3200 input connector R, S, T.

(b)The installation of creepage breaker

When a creepage breaker is connected to the input connector R, S, T, in order to Avoid error action, must choose the one which is not influent by the high frequency
For example: the NV series of Sanling electric machine company (product in 1984 or later), the EG, SG series of Fushi electric machine company (product in 1984 or later)

(c)The installation of electromagnetism contactor

Inverter mains side has not installed electromagnetism (MC) , it also can be used. The electromagnetism (MC) can substitute breaker(MCCB) be cut for the main circuit Current order, but when the electromagnetism be cut by one side once, and can' t be trigged any more , and the electromotor slide stop. When one side close /cut, the electromagnetism contactor can made load run /stop. But open/close frequently will cause inverter accident , please pay more attention. When use trig resistor unit, it can across the release junction of over loading Relay,do the order control.

(d)The sequential connection of connector

The posture line of input power supply can be connected to the terminal board R, S, And T, everyone is ok, and leave alone the order.

(e)AC reactor

When a inverter is connected to a large capacity power supply transformer(600KVA or more),or when across/cut a posture and location advanced capacitor(power factor Compensator),it makes a large peak value current when input current circuit,and Break the part of the commute convertor .In this case, install a DC (direct current) Reactor (option) to the inverter,or add a DC (direct current) reactor to the Input channel. To install a reactor can improve the frequency factor of the mains side effectly.

(f)Surge absorber

If geist load (electromagnetism, relay, magnetic valve, electromagnetic brake) Is connected to the adjacent inverter,and use a surge suppresser at the same time.

(g)The setting of the mains side yawp filter

To install yawp filter can reduce the high frequency noise wave when inverter flow to the current.

wiring example 1:please use the special yawp filter of the inverter.

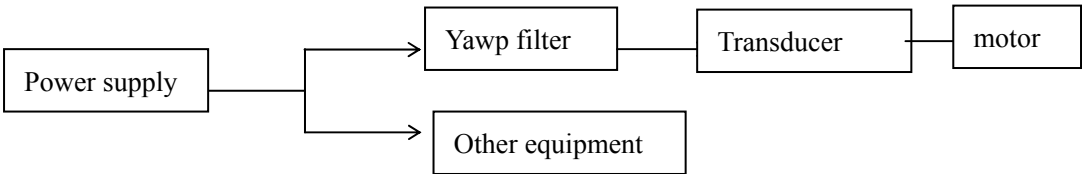

The setting of the power supply side yawp filter

The main loop output connection matters need attention

(a) Connect output connector with load

To connect output connector with electromotor elicitation line U, V, W, use forward Circulate dictate to validate the forward circumrotation of the electromotor (CCW: To observe the electromotor load side is the counterclockwise circumrotation.) If electromotor's direction of circumrotation isn't correct, exchange any two between output connector U, V, W.

(b) Forbidden absolutely (connect the input power supply with output connector U V W)

Don't connect input power supply to the output connector U, V and W

(c) forbid to output circuit short or grounding

Don't touch output circuit directly or make the output line touch inverter's crust, otherwise it cause electric shock or grounding fault, it is very dangerous. Besides, don't short circuit the output line.

(d) forbid to connect the posture and location advanced capacitor or LC/RC yawp filter

Don't connect the posture and location advanced capacitor or LC/RC yawp filter To output circuit.

(e) Avoid installing magnetic starter

If connect a magnetic starter or electromagnetism contactor to the output circuit, And if the inverter connect with load during working, because the current inburst, the inverter protect the circuit action. electromagnetism contactor act only when inverter stop outputting.

(f) The installation of thermal overload relay

Inverter contains one electron overload protection function, of course, drive several electric motors in one inverter, or when use one multipolar electric motor, must connect one thermal overload relay. Besides, thermal overload relay must set the rated current to be the same nominal rating of the electric motor data plate.

(g) The installation of output side yawp filter

To set special yawp filter in the output side of inverter, it can reduce wireless noise and disturb the effect of noise.

Disturbing noise:

Because the electromagnetism disturbs, and noise modulate in the signal wire, it cause the control to produce error action.

Wireless noise:

If the inverter reality or cable emit high frequency, and made wireless transmitter-receiver set produce noise.

(h)The countermeasure to the interfere noise

In order to control the interfere noise of the output end, besides use the yawp filter, make the connection line whole penetrate the grounding metallic conduit. Devide with signal wire to 30cm or more, the effect of interfere noise reduce.

(i)The countermeasure to the wireless noise

(j)The distance of wiring between inverter and motor

If the total distance of wiring between inverter and motor is too long or the inverter signal carrier frequency (main IGBT switch frequency) is relatively high, The wave in harmony from cable leaks the electric current and will have a unfavorable impact on frequency inverter and outside equipment .

The frequency of the signal carrier can be established by the constant 01-26.

The table of wiring distance between frequency inverter and motor

wiring distance between frequency inverter and motor	The longest Is 50m	The longest Is 100m	More than 100m
Carrrier frequency (the parameter01-26 of set value)	8Khz or the lower	5KHz or the lower	3KHz or the lower

380V grade main loop mix line and need related ancillary equipment consult the form

specification	Applicat ion motor kW	Wire size mm ²	the main loopt connector screw	No - fuse air breaker MCCB A	Electromagne tic contactor MC A	Maximum relay RT adjusted valure A
CS3200-GR75T4	0.75	2.5	M3.5	10	10	
CS3200-G1R5T4	1.5					4
CS3200-G2R2T4	2.2	4		15	20	6
CS3200-G3R7T4	3.7					9.5
CS3200-G5R5T4	5.5	6		30	35	12.5
CS3200-G7R5T4	7.5					17
CS3200-G011T4	11	10	50	50	24	
CS3200-G015T4	15				32	
CS3200-G018T4	18.5	16	M5	75	50	38
CS3200-G022T4	22					45
CS3200-G030T4	30	25	M6	100	80	60
CS3200-G037T4	37					75
CS3200-G045T4	45	35	M8	150	100	89
CS3200-G055T4	55					108
CS3200-G075T4	75	60		180	180	144

CS3200-G093T4	93		M10	350	250	172
CS3200-G110T4	110	90		400	400	202
CS3200-G132T4	132					240
CS3200-G160T4	160	120	M12	500	600	290
CS3200-G185T4	185	150		600		340
CS3200-G200T4	200	180		600		600
CS3200-G220T4	220	240	415			
CS3200-G250T4	250	270	M16	800	1000	470
CS3200-G280T4	280					530
CS3200-G315T4	315	350		1000		1000
CS3200-G400T4	400		500	1500	1500	780
CS3200-G450T4	450	2000		2000	1000	
CS3200-G500T4	500					
CS3200-G630T4	630					

3-4、Grounding

Grounding resistance:

200V gradation: 100 Ω or the less

400V gradation: 10 Ω or the less

660V gradation: 5 Ω or the less

Don't make CS3200 series inverter and electric welder or other large current electric equipment communal grounding. Ensure the whole grounding wire of canal and large current electric equipment lead to pave apart.

- Use the regulation standard grounding wire, and make the length as shorter as possible.
- When use several CS3200 series inverter side by side, ground the equipment following the picture (a), don't follow the (c) to make grounding wire to form loop.
- Please follow the picture (d) to connect the CS3200 series inverter and electric motor grounding.

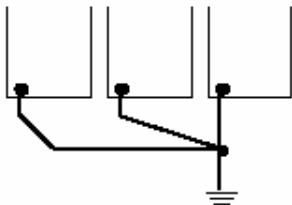

(a) correct

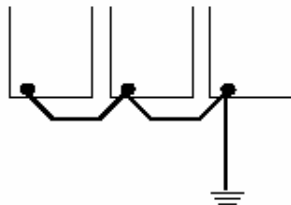

(b) not commend

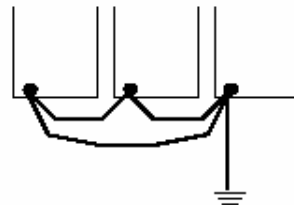

(c) not correct

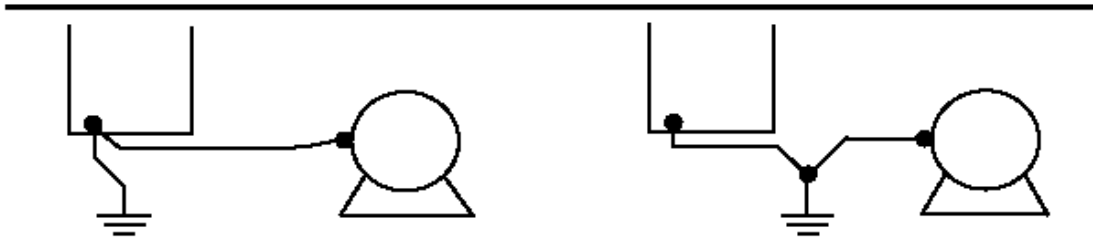

(d) correct

(e) not commend

3-5、Wiring of the controll circuit

The connector of control circuit as following

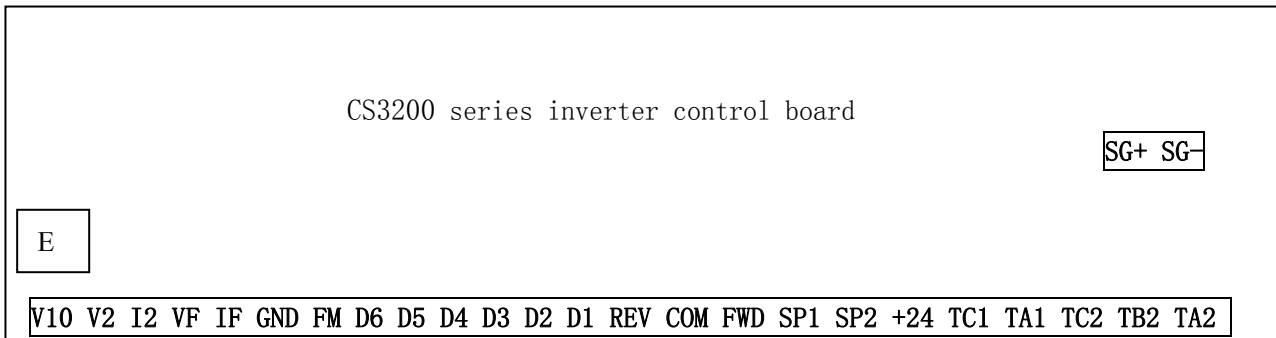

The function of control circuit connector

The following table summarize the function of control circuit connector , according to every connector function to connect lead.

sort	connector	Signal function	instruction		Signal electrical level
Multi-function input signal	FWD	Forward run /stop	When close forward run, open reverse run	Multi-function connection point input 03-00~03-05 set	Photoelectricity coupler isolation input: ON/OFF inside 24VDC/8mA
	REV	Reverse run /stop	When close reverse run, Open stop		
	D1	Multi-speed statement 1	When close effective		
	D2	Mutiple speed statement 2	When close effective		
	D3	Mutiple speed statement 3	When close effective		
	D4	Second Acc/Dec time choise	When close effective		

	D5	Free parking	When close effective		
	D6	Fault reset	When close reset		
	COM	Multi-function Input common connector			
Analogue quantity input signal	V10	+10V output current	Analog statement +10V current		+10V the largest permission current 20mA
	V2	Analog input voltage	0~ +10V/100%	03-19 set	0~ +10V (20K Ω)
	I2	Analog input current	0/4 ~ 20mA/100% *		0/4~20mA (250 Ω)
	VF	Analog input voltage	0~ +10V/100%	03-23 set	0~ +10V (20K Ω)
	IF	Analog input current	0/4 ~ 20mA/100%		0/4~20mA (250 Ω)
	GND	Analog signal common ground	0V		
Multifunction output signal	SP1	Open set electric pole 1	When overload prewarning conduction	(03-06=15)	The largest output 48V 50mA
	SP2	Open set electric pole 2	When under voltage conduction	(03-07=18)	
	COM	Open set electric pole output common ground			
	24V	Digit signal current			Between com can input DC24V, the largest 200mA
	TA1	Operating signal (normal open connection point)	When operating stop	Multifunction connection point output (03-08=1)	Connection point content 250VAC, 1An or smaller 30VDC , 2A or smaller
	TC1				
	TA2	Fault connection	When fault , the Connector TA2	Multifunction connection	
	TB2				

	TC2	point output (normal open/normal close connection point)	And TC2 close , Connector TB2 And TC cut	point output (03-09=2)	
Analog output signal	FM	The frequency meter output	0~ +10V/frequency Fmax	Multifunction Analog quantity monitor (03-30)	Output 0~+10V Load 2mA or smaller
	GND	Analog signal common ground			
Communication signal	SG+, SG-	RS-485 communication positive signal RS-485 communication negative signal			When it is in the terminal ,connect JP485 linker to the TER side.

3-5-1、The connection of control circuit connector

Insert the lead to the underside part of connector row , and screw down by the screwdriver ,stripping length of lead scarfskin must be 7mm.

3-5-2、The connection control circuit matters need attention

Apart the lead of control circuit and main circuit lead and other current cable, prevent the error action of interfere noise. Control circuit connector use wring screening line or twinwring screening line, and connect the screen scarfskin to inverter connector E, the connection distance must be less than 50 meter.

3-6、wireing check

After finishing the installation and connection check the following items.

- Whether the connection is correct.
- Whether the fault line nob or screw stay in the equipment.
- Whether the screw is firm and tight
- Whether the nakedness lead of connector contact other connectors

4、Operate



Warning

●Only after fixing the front cover connect the input current. when electrifying , don' t unload the outside cover.

If not obey the warning , it causes the electric shock.

●When choose retry function (02-07) , don' t close to the inverter or load, because it will suddenly restart as soon as stop. (Even the inverter restart, the other machine system must ensure the person safety.)

If not obey the warning , it causes the person injury.

●The setting function cause the stop button inert, so must install a single instant stop button.

If not obey the warning , it causes the person injury.



Caution

●Mustn' t touch the radiator or resistor, because of the high temperature.

If not obey the caution, it will burn out the body.

●Because it easily made the low speed to be high speed runned, so check the safetywork area of electromotor and machine equipment before operate.

。 If not obey the caution , it causes person injury and equipment break down.

●If needed , install a single band-type brake.

If not obey the caution , it causes person injury.

●Don' t change the connection when operating.

Otherwise it will damage the equipment or inverter

This chapter narrate the basic operation step of CS3200 series inverter, the particular operation explanation illumint in the following chapter.

4-1、The choice of operation mode

Method of operation	Function code 01-00
Numeric front panel operation	0
Exterior connector operation	1
RS-485 operation	2

The frequency setting method is set by frequency set choices 01-03, the frequency set method

1 and frequency set method 2 form all kinds of combination. When the choice 01-03 is frequency set method 1, follow the table.

Frequency set	Function code 01-01
Front panel set	0
Exterior set V2 (I2)	1
Exterior set VF (IF)	2
Front panel potential device(with the potential device type)	3
Ascending and descending control	4
RS-485 set	5

4-2、The examination before test running.

In order to ensure safety, before running first time must relieve the machine linker, so that apart the electromotor and machine equipment. If before running first time link the electromotor and machine equipment, pay more attention, avoid the possible dangerous cases. Check every content before test running.

- Whether the lead and connector connect correct.
- Whether the lead nob cause short circuit
- Whether the connector is firm and tight
- Whether the electromotor is tightly installation

4-3、Trial operation

When the system is ready, put though the current, and check the inverter whether it is normal. When it put though the current, the numeric keypad display the light. If discover the problem, must cut off the power supply.

4-4、Operation examination

check the following step during operating

- Whether the electromotor run calmly
- Whether the running direction of electromotor is correct
- Whether the libration or noise of electromotor is normal
- Whether the acceleration and deceleration is calm
- Whether the current fit the load value
- Whether the state LED indicated light and the show of digit exerciser is correct

5、Front panel operation

5-1、Front panel function

Instruction of running state and data unit of inveter

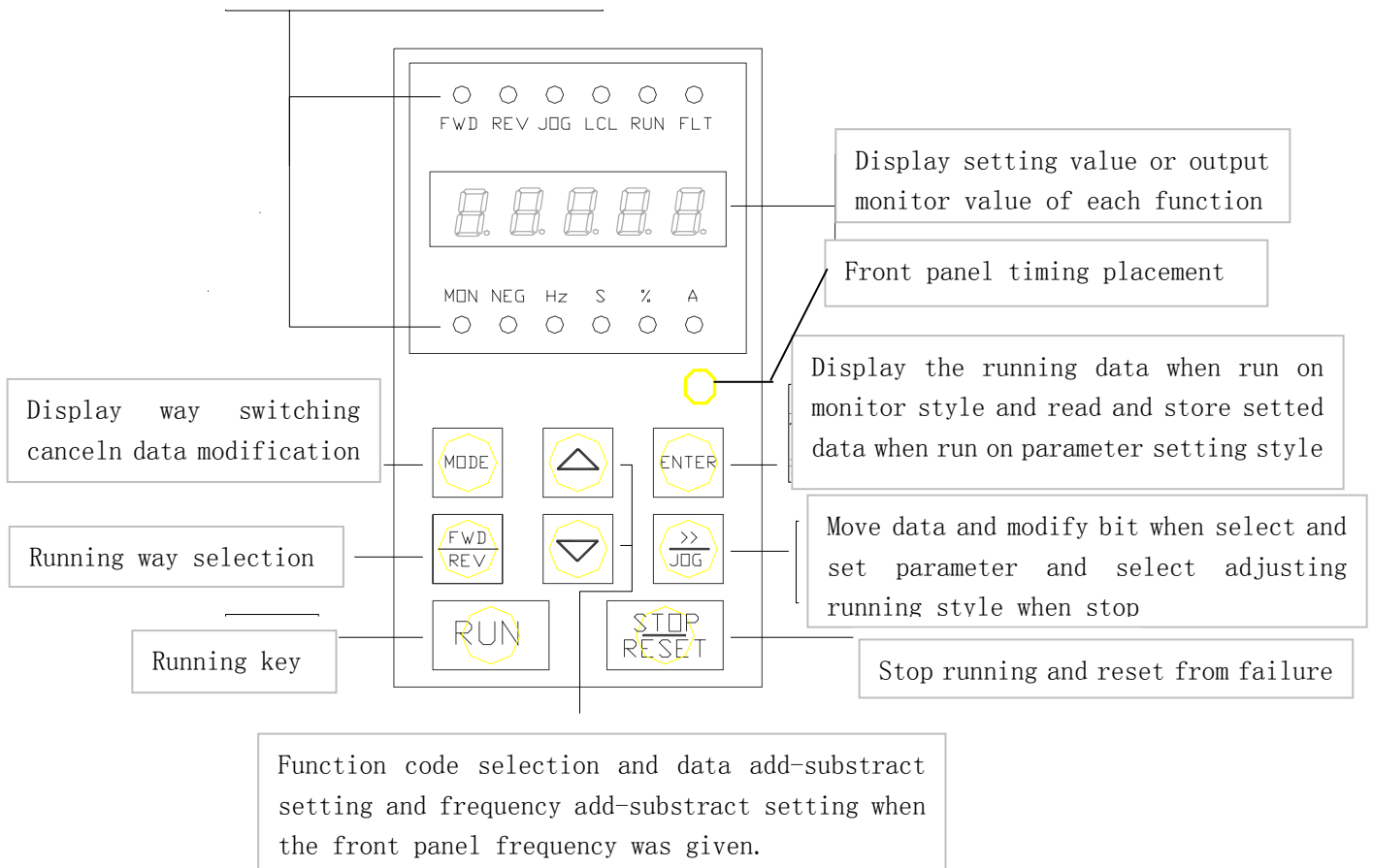

Indicated lamp

RUN: The inverter is working, the indicated lamp light

JOG: To indicate nonce to be adjusting microinching method of operation, switch by the JOG button.

LCL: To indicate nonce to be front panel method of operation and front panel frequency set method, decide by P0100 and P0101.

FWD: Forward indicate. Indicate the current operation statement to be forward direction.
When operating, it light. When stopping, it flash.

REV: Reverse indicate. Indicate the current operation statement to be negative direction.
When operating, it light. When stopping, it flash.

FLT: Fault indicate. When the inverter fault, the lamp light.

MON: Indicate nonce to be method of operation monitor.

NEG: Indicate nonce to show data to be negative value, only when run the method of operation monitor.

Hz: Hertz **S:** Sec **%:** Percentage **A:** Ampere

5-2、The display modes of inverter

Operate method of monitor

(When operate method of monitor,if press Δ ,the ∇ button enter the frequency set mode d.)

(When operate method of monitor,if appear the fault and alarm, it display the fault protection method E or alarm method.)

Parameter set mode P

Parameter set mode U

Frequency set mode

Δ , ∇ , button change the mode

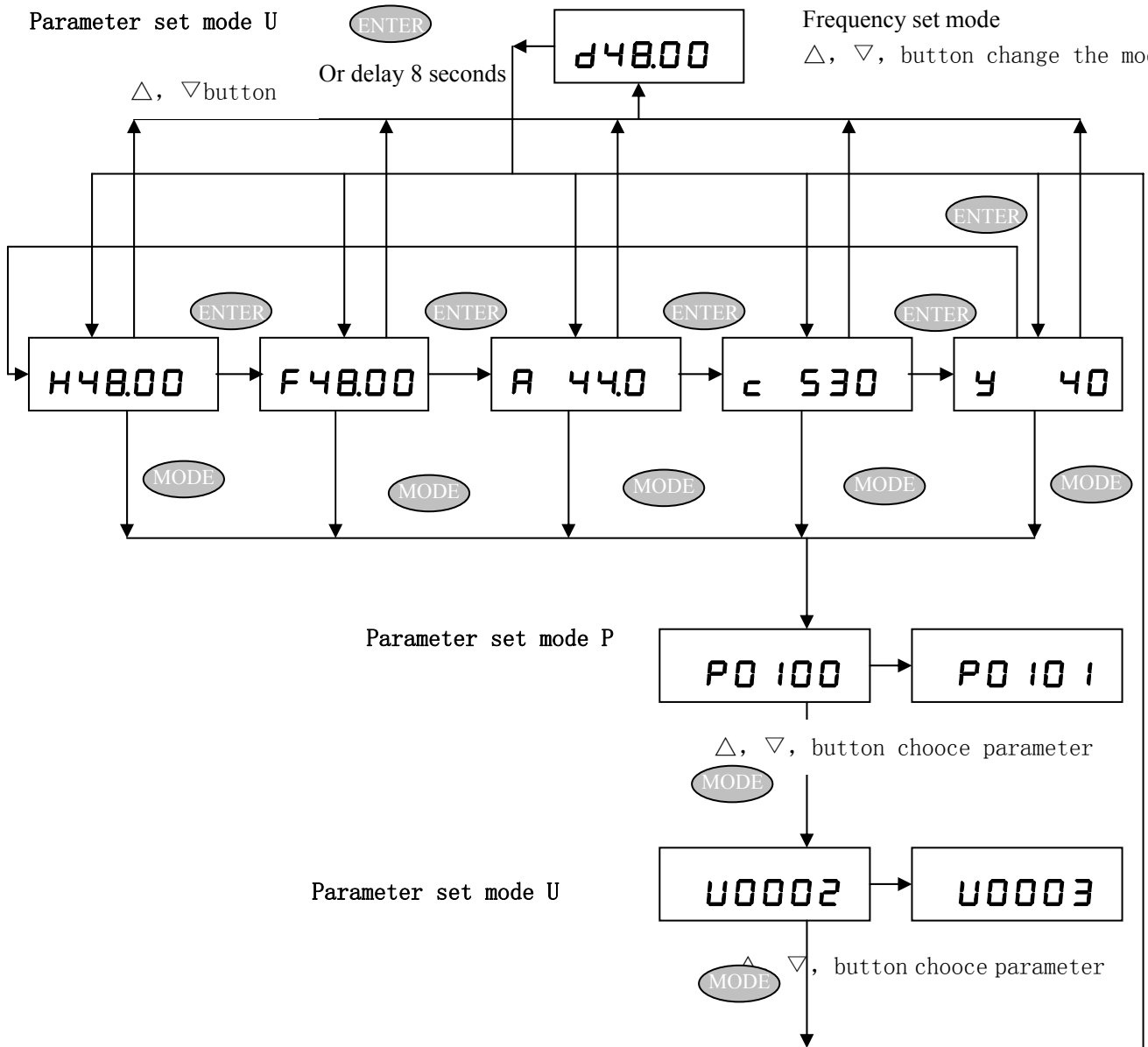

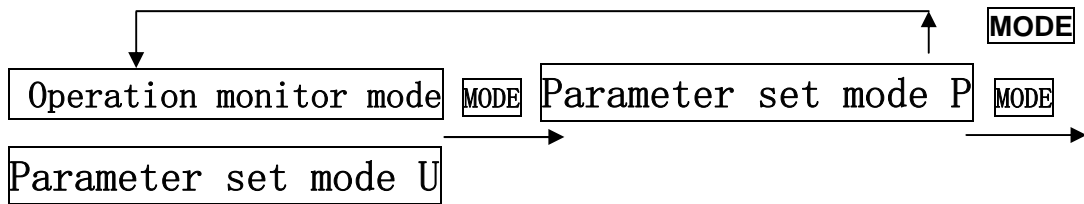

Operateion monitor mode

Operation data monitor

When it's operation monitor mode, per press **ENTER** button, the programmer change.
Use front panel directly to set frequency

When operate monitor mode, can press Δ , ∇ button to enter frequency set mode, now

display example. **d45.00**

Press Δ , ∇ and \gg button again to adjust to the needed frequency set,

such as 48.88Hz, now display. **d48.88**

Press **ENTER** button,

Exit the frequency set mode, return to the operation monitor mode,

now display. **H48.88**

When operate the frequency set mode, can not press **ENTER** button, only to wait 8 seconds to return to the original operation monitor mode .

When operate and stop ,it can change the set value of frequency.

Fault monitor

- When operation monitoe mode, and appear fault and alarm, it will display fault and alarm message.
- If the inverter FLT indicated lamp light, it show the coming fault.
- If the fault disappear, press the reset button **RESET/STOP** to reset the fault.
- If it show the serious fault, only to cut off the electricity and reset.
- If the fault has not reset or the screem has not cleaned, the front panel will display the fault code all the time (refer to the fault diagnosis). The consumer can press **ENTER** button to clean the screem, but the fault has not reset. If have not pressed any buttons in 10 seconds, the fault code will show on the front panel.

Parameter set mode

Set the inverter parameter and check the operating situation of inverter, then set and check P and U parameter at the same time. In order to make the system operate the best state, it must adjust some parameter value.

5-3、The step of set data(LED front panel)

1. Press the **MODE** button to choose parameter set mode P or parameter set mode U.
2. Press **>>**, **▲** or **▼** buttons to shift to the needed revised parameter code.
3. Press **ENTER** button to read the data, then the cursor flashes.
4. Press **>>** button to shift the cursor to the expected location. Press **▲** or **▼** button to change the data.
5. Press **ENTER** button to keyboard the data, and display the parameter code, such as after press **ENTER** button, AL1 indicates the set is wrong, the data have not despoisted.
6. If press **ENTER** button before **MODE** button, the revised data is uneffective, and the data is the same before renewing.

- **Watch out:** When it is in the following cases, it can not change the data.
 - When the inverter is operating, it can not change the parameter. (refer to the function table)
 - Start the lock function of inverter in the 10-01[parameter lock]

5-4、The monitor step of operating data(LED front panel)

1. Press **MODE** button to choose parameter set mode P or parameter set mode U.
2. Press **>>**, **▲** or **▼** button to shift to the wanted parameter code.
3. Press **ENTER** button to display the data, now the cursor do not fla
4. Press **ENTER** or **MODE** button again, quit the data show, display the parameter code.

The following example is the acceleration time 01-05 change from 015.0 to 016.1.

1	H 5 0.0 0	- Display the output frequency 50.00Hz, Press (MODE) button to parameter set mode P.
2	P 0 1 0 <u>0</u>	- P0100 appear. And the cursor point to the last number 0. - Press >>, Δ, ∇ button to choose the needed set function code.
2	P 0 1 0 <u>5</u>	- P0105 appear. - Press (ENTER) button .
3	0 1 5. <u>0</u>	- If the expectation value is 015.0, And the cursor point to the number 0. - Press (>>) button three times, move the cursor to 5
4	0 1 <u>5</u> .0	- Number 5 in the 01 <u>5</u> .0 is effective., then press (Δ) button.
	0 1 <u>6</u> .0	- The value add to 01 <u>6</u> .0. - Press (>>) button, move the index to 0.
6	0 1 6. <u>0</u>	- 016. <u>0</u> display, the “0” of 016. <u>0</u> is effect. - Press (Δ) button.
7	0 1 6. <u>1</u>	- Press ENTER button . - Write 016.1. - P0105 display. The acceleration time have been changed from 015.0 to 016.0 second.
7	P 0 1 0 5	If have not pressed ENTER button. - Press MODE button. - P0105 display. The acceleration time remain 015.0.
8	U 0 0 0 2	- Press MODE button. - U0002 display.
9	H 5 0.0 0	- Press MODE button. - H50.00 display , return to the operation monitor mode.

6、Function introduction

6-1、Prepare the parameter set

6-1-1、Parameter set

The following table narrate the function of parameter set:

P1001=1 (parameter lock)	Except 01-04 , the other parameters can not set.
P0704=1 (clean the fault message)	07-01, 07-02, 07-03 change to ----
P0705=1or 2 (clean the accumulated running time or KWH energy meter)	00-10 , 00-11or 00-26, 00-27 clean to 0
P1000=22 (renew the factory value set)	The all function parameter renew to the factory set value.

10-00、Renew the factory set value

When the paramete set to 22, it is effective ,all function parameter renew to factory set value.

10-01、Parameter lock

When the parameter set to 1, it is effective, all parameters(except front panel frequency set) can not revise.

10-05、Machine speed modulus

Use to adjust the show of machine rotate speed.

$$\text{Machine rotate speed} = \frac{\text{Output frequency}}{\text{The largest output frequency}} \times \text{machine speed modulus}$$

01-04、Front panel set frequency

The front panel set value and frequency set mode $\square \times \times . \times \times$ the set values are the same when display

6-1-2、Starting-up show the picture choice(10-02)

0: output frequency (H) such as: **H48.00**

1: set frequency (F) such as: **F48.00**

2: output current (A) such as: **A 9.0**

3: selfset function display c **c 542** (set by 10-03)

4: selfset function display y **y 380** (set by 10-04)

6-1-3、Selfset display function choice 1 (10-03)

When set operation monitor mode c ,it displays the parameter serial number.

For example : The set value of 10-03 is 0001 , and the parameter 00-01 represent output frequency. So when selfset function display c, it represent output frequency.

Such as 0005: The voltage of direct current main lead (U) **c 540**
540V direct current voltage

Such as 0006: output voltage (E) **c 379**
The voltage of outlet line 379V

6-1-3、Selfset display function choice 2 (10-04)

When set operation monitor mode y, it displays the parameter serial number.

Such as 0005: The voltage of direct current main lead (U) **y 540**
540V direct current voltage

Such as 0006: output voltage (E) **y 379**
The voltage of outlet line 379V

Such as 0403: The process circulate that the remaining time display.
y 13.5 Remaining time 13.5 second

6-1-4、The state of input connector display(00-12)

If the D1 connector transmit , other connectors cut off.

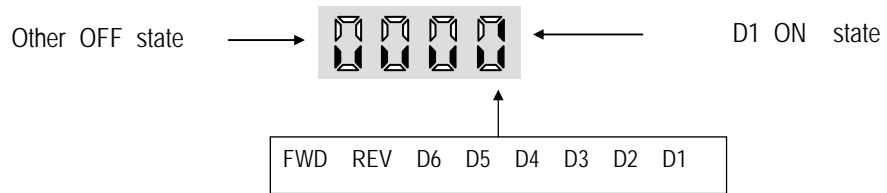

6-1-5、The state of output connector display(00-13)

exp. the SP1 connector transmit, other connectors cut off.

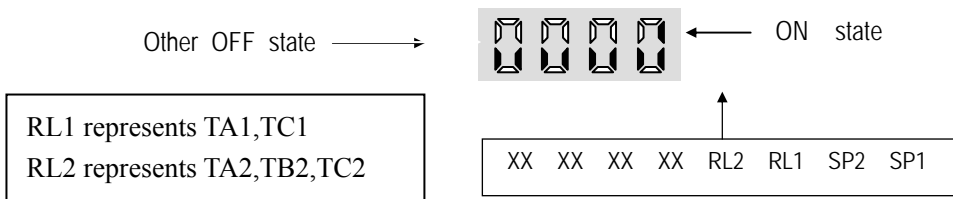

6-2、 The set of basic parameter

6-2-1、 The set of V/F speciality

Any V/F speciality, that is to say set basic frequency, the largest output voltage, angular force compensation and so on. The set value must accord famous brand data of electromotor.

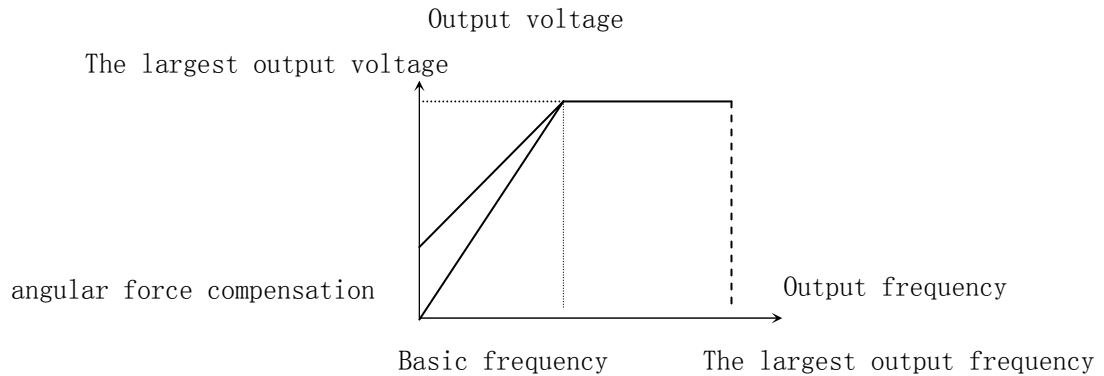

01-11、 The basic frequency:

It is the lowest frequency that the inverter output the rated current, and the output voltage from basic frequency keep steadiness. It can set in the range of the largest output frequency.

01-10、 The largest output frequency

It is the largest frequency that the inverter output.

01-12、 The percentage of output voltage

The ratio of output voltage and electromotor rated voltage.

Use this function to adjust the output voltage to accord different need of V/F speciality.

Output voltage = electromotor rated voltage \times the percentage of output voltage
If the voltage of electric network is lower than set value, and the output voltage only direct ratio to the input voltage.

Because automatic voltage adjusts the function (AVR) systematically, CPU measures the voltage of bus bar of direct current of the frequency inverter to regulate in real time automatically, so the settlement state when when the voltage of the electric wire netting fluctuates , enable outputting the voltage to change very small , its V/F characteristic is close to the voltage of inputting of amount all the time.

01-13、 The torque is compensated

Can carry on the voltage to promote according to the load characteristic and torque demand within the range of low frequency

- Notices: Torque take place excitation phenomenon carefully when being person who compensate too big, magnetism saturation will produce heavy electric current make electrical machinery generate heat.

01-09, The lowest output frequency

It is that the frequency inverter begins the minimum frequency while outputting the voltage to output frequency minimumly.

While starting , when the frequency order is greater than the minimum frequency of outputting , begin to run

When the frequency order is smaller than the minimum frequency of outputting , stop exporting.

Factory set : 0.50Hz

6-2-1, V/F mode (01-15)

Output voltage

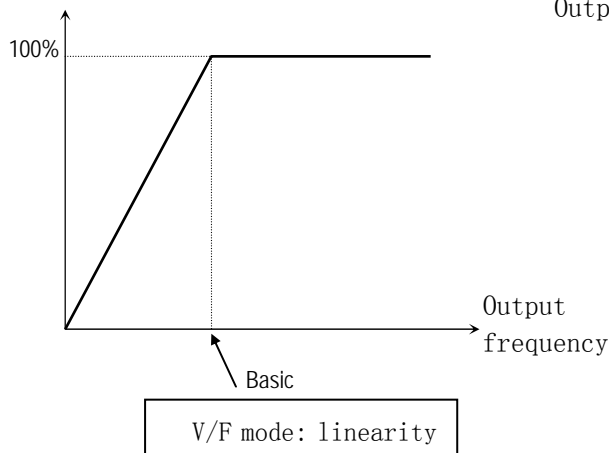

Output voltage

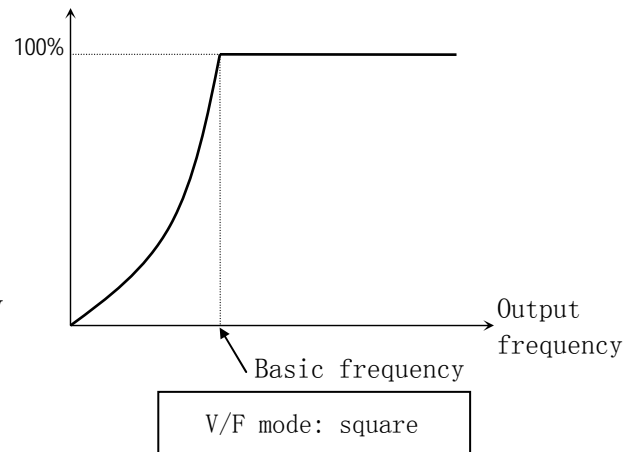

- 0: Linear V/F mode, relatively suitable for pulling the voltage of outputting to keep invariable permanent torque load compared with ones that output frequency. Such as the conveyor belt, bicycle parking equipment, etc..
- 1: The square V/F mode, the ones that are relatively suitable for pulling the voltage of outputting with frequency of outputting, than for the turning into torque load of shape of the parabola. Such as the fan, pump equipment, etc..
- 2: It is self-defining V/F mode, occasion not special use user can the wanton to last voltage of outputting with outputting frequency than.

As the increase of the voltage of V/f mode will make the motor torque increase , but too much increase will cause the following situations :

- Make the work of the frequency inverter abnormal because the motor passes the excitation
- The motor is overheated or vibration is too big.
- While increasing the voltage, increase the voltage step by step while examining the electronic electromechanics and flowing.

6-2-2、Frequency limit (01-07, 01-08)

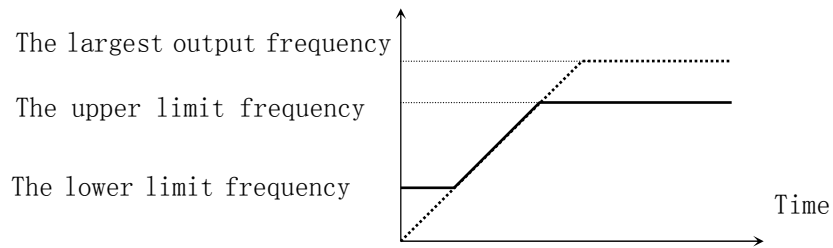

(a) The upper limit frequency (01-07), set the upper limit value of frequency order.

(b) The lower limit frequency (01-08), set the lower limit value of frequency order.

(c) This function is used for limiting operation frequency , confine operation frequency to on frequency , lower limit range.

6-2-3、Use 2 kinds to add and moderate time (01-05, 01-06, 01-31, 01-32)

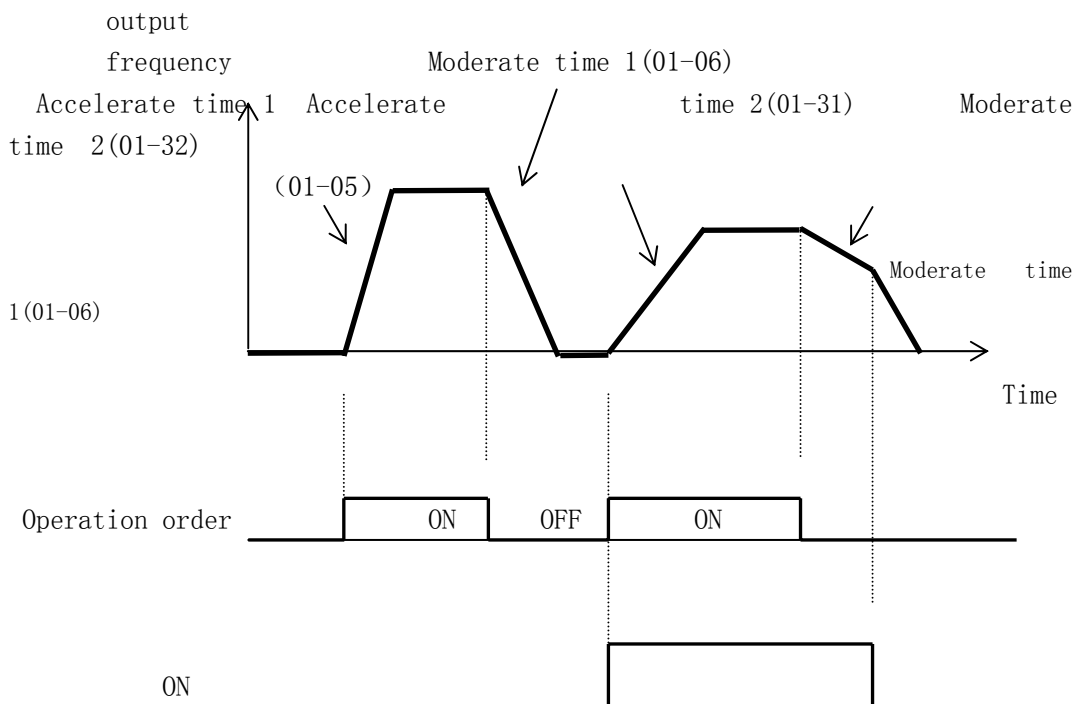

Add and moderate time to switch over
(sub D1-D6 of end is chosen)

When stop mode to choose “moderate time” (02-16=0).

Use multifunction connection point input to choose (03-00, 03-01, 03-02, 03-03, 03-04 or 03-05) set “9 (add and moderate time to switch over)”, and accord add and moderate time to switch the ON/OFF of connector to choose add and moderate time.

OFF: 01-05 (Accelerate time 1), 01-06 (Decelerate time 1)

ON: 01-31 (Accelerate time 2), 01-32 (Decelerate time 2)

The number of parameter	name	unit	Set range	Factory set
01-05	Accelerate time 1	0.1s (more than 1000s is to be 1s)	0.0~6000s	10.0s
01-06	Decelerate time 1	0.1s (more than 1000s is to be 1s)	0.0~6000s	10.0s
01-31	Accelerate time 2	0.1s (more than 1000s is to be 1s)	0.0~6000s	10.0s
01-32	Decelerate time 2	0.1s (more than 1000s is to be 1s)	0.0~6000s	10.0s

● Accelerate time

Set output frequency to depend the needed time which forbid to accelerate to the largest frequency.

● Decelerate time

Set output frequency to depend the needed time which the largest frequency decelerate to stop.

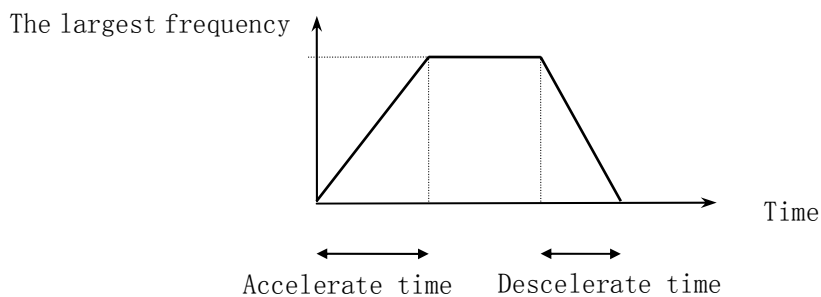

6-2-4、The speciality of soft sartup (01-37)

In order to prevent the mechanical equipment from impact while starting/stopping, may choose S curve to go on with moderating controlling .

Use S curve can lengthen setting time of accelerate and decelerate

The S curve characteristic time is 0 from acceleration to the normal acceleration confirmed of setting for value.

Output frequency

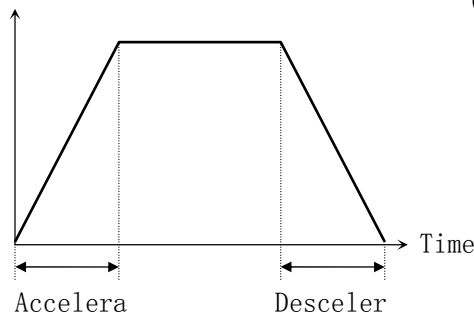

S type =linearity

Output frequency

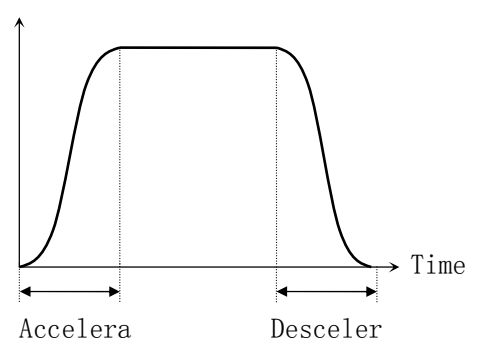

S type = 3

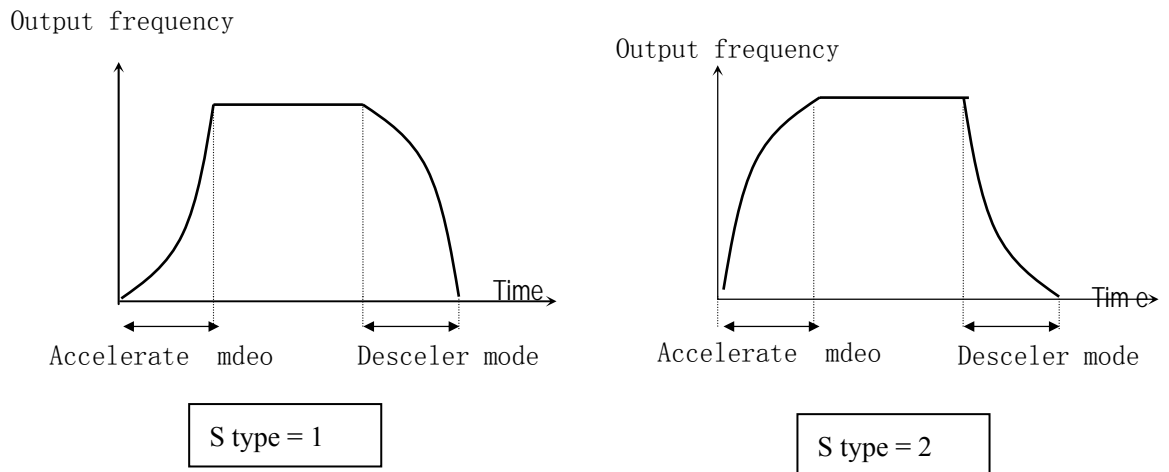

6-3、Running statement

6-3-1 Analog frequency set mode

- (a) Set 01-01=1, V2 input voltage signal (0~10V), input resistance is 20K Ohm. I2 input current signal, input resistance is 250 Ohm.
- (b) Set 01-01=2, VF input voltage signal (0~10V), input resistance is 20K Ohm IF input current signal, input resistance is 250 Ohm.
- (c) Analog frequency set value is limited by the maximum of frequency (01-10), the upper limit frequency (01-07), the lower limit frequency (01-08).
- (d) 0~100.0% analog frequency set value correspond to 0~ the upper limit frequency (01-10).
- (e) Set 01-01=3, input front panel potentiometer (with potentiometer).

6-3-2、Carrier wave frequency (01-26)

The frequency of the signal carrier increases, the electromagnetic noise of the electrical machinery reduces, and disturbing noise or leaking electric current to increase. Generally speaking, the frequency inverter signal carrier frequency of the small power produces factory value is higher, and contribute to reducing the electromagnetic noise. The frequency inverter signal carrier frequency of the large power produces factory value is lower, can contribute to reducing the power device noise, and reducing the motor's leaking electric current.

6-3-3、Reversal forbidden (02-21)

It isn't accept control circuit end son or figure reverse operation order that send of operating etc. to operate backward to forbid
 This set is used in the application occasion not allowing the equipment to operate backward

02-21 set	explanation
0	Can reverse running
1	Can' t reverse running

6-3-4、Time of applying the brake of direct current while starting (01-19)

Restart after the motor making freedom slide while operating stops, set the starting DC drakeing time in constant 01-19 by unit on 0.1 second.

While constant 01-19 set as “0.0”, do not in DC brake while starting, and the min output frequency speed up to start.

01-18 DC brake choose: 0:no 1: yes

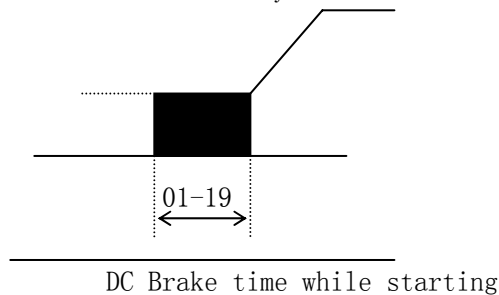

6-3-5、Choose the stopping mode (02-16)

Choose the suitable stop method

0: stop with speed down

1: free stop

(a) stop with speed down (02-16=0)

Positive /negative running order OFF, the motor will speed-down and stop by setting. If the speed-down time is short or loading inertance is great, it will have the overvoltage(ou) faulty. And in this case, can add speed-down time , installate brake resistance , or break unit (choose device)

brake torque size:

No braking resistance:braking torque is the 20% of machine rating torque.

have brake resistance:the brake torque can be 100% of machine rating torque.

(b) free stop (02-16=1)

Recall positive(negative)running order , the mOTOR will stop at once with free slipping.

01-20、 DC brake voltage

The parameter set for the DC brake voltage value input to machine while is DC braking. the value is based on inverter rating voltage. so while setting it, should make it by little and crescent.

01-22、 DC brake time while stopped

Dc brake voltage lasted time while stopped. and will not in DC brake in setting to 0.0seconds.

01-21、 DC brake starting frequency while stopped

Inverter speed down to the frequency, will output the DC brake voltage.

DC brake frequency (01-21) should not be too high, or will infact the DC brake.

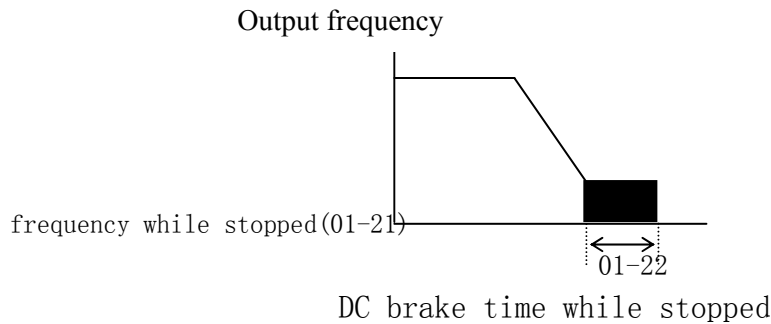

6-3-6、 slippage compensate plus (01-23)

This is the function keeping the electrical machinery steady in speed. Because load makes the speed of the electrical machinery drop, The electrical machinery increases its output frequency (higher than the frequency of establishing) by increasing the speed of the electrical machinery. The frequency inverter increases the frequency of outputting through delta frequency. In order to obtain good control performance The parameter of the electrical machinery must be established correctly.

Slippery difference compensation when establishing as 0

$$\text{Delta frequency} = \frac{\text{Output electric current - no load current}}{\text{Specified electric current - no load}} \times \text{Amount Slippery difference}$$

$$\text{Output frequency} = \text{setting frequency} + \text{Delta frequency}$$

6-4、 output fuction

6-4-1、 output simalation

(a) analog quantity monitoring and choosing (03-30)

Set	Output project that analog quantity monitors
0	No output analog
1	Output frequency (the largest frequency with 10V)
2	Output current (200% The specified electric current of electrical machinery is corresponding 10V)
3	Output the voltage of bus bar of direct current (1000V to 10V)
4	Output the voltage (The specified voltage of the electrical machinery is corresponding 10V)

*overvoltage valua : 200Vgrade is 410V, 400Vgrade is 820V.

(b) simulation set up (03-31)、(03-32)

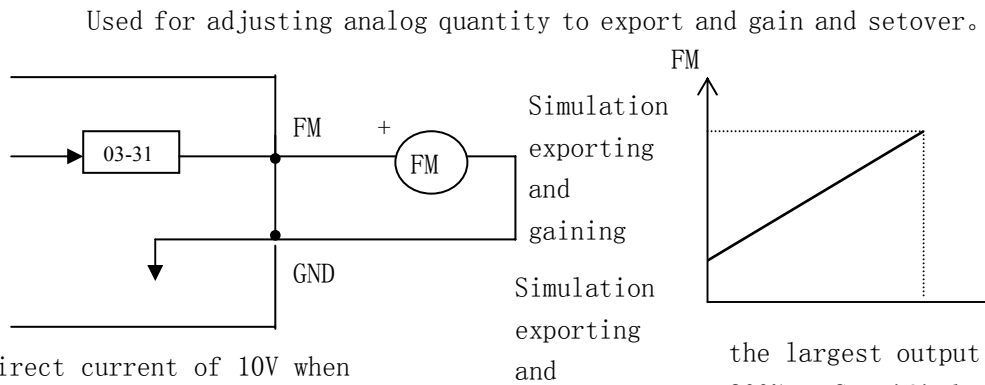

Press for the direct current of 10V when 100% is exported electric current ,etc.

Simulation exporting and gaining
Simulation exporting and

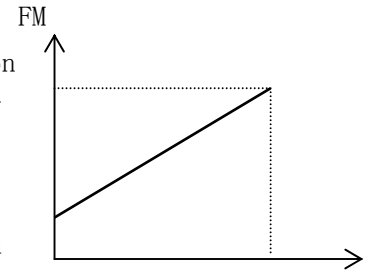

the largest output frequency 200% Specified electric current ,etc.

6-4-2、Export and choose multi-functionally (03-06, 03-07, 03-08, 03-09)

Output end son in the multi-functional contact (TA1、TC1 和 TA2, TB2, TC2 function can press not needing it change through establishing parameter 03-08 and 03-09) 。 The sub end sub SP1 of the multi-functional output end and function of SP2 (COM is the public end): set for 03-06and 03-07.

setting	Action name	Explanation	Following page
0	no	No poutput	
1	At funning	Is it input to act as to is it close when exporting to have	
2	The trouble signal	Frequency conversion is closed while producing the trouble	
3	Zero speed	The frequency inverter has not been closed while outputting the voltage	
4	Operation frequency reaches the frequency of establishing	Operation frequency > establish frequency-frequency check range	38
5	Reach the frequency level measuring value	Output frequency in frequency measures the basic range	
6	More than the frequency level measuring value	Output frequency \geq the basic of frequency measures	
7	Less than the frequency level measuring value	Output frequency \leq the basic of frequency measures	
8	Operation frequency as down frequency value		
9	Operation frequency as up frequency value		
10	In back running	Input the signal of back running	
11	Counting device arriving and establishing value	The multi-functional input end defines and touches off	45

12	Counting device reaches the largest value	introduction for the counter	
13	Timer function	Timer device output	43
14	VF(IF)losing the feedback signal	When the feedbacking value is reduced to and is smaller than the voltage of measuring , output a contact signal.	
15	The overload of the electrical machinery is predicted alertly	The overload of the electrical machinery is predicted alertly	
16	OL the electron is predicted alertly in hot year	The overload percentage of the electrical machinery exceeds 50% 50%	
17	The trouble reports to the police while resetting automatically	The trouble reports to the police while resetting automatically and exports	
18	Ove the voltage		
19	Outside error	Outputting of outside error while been braked	
20	Prepare of inverter	After get electric, all of inverters are normal.	
21	V2 (I2) Frequency order losing	Frequency order less than min value	
22	oL electron over heat warning	Step running of program finished	49
23	PLC circulate cyclic finished	Circulate cyclic of program running finished	
other	Retain		

6-4-3、frequency check(03-10, 03-11)

While multifunction terminal outputting select is setting to “frequency check” (set as 5,6, or 7), it is in effect.

(a) Reach to frequency check (set as” 5”)

frequency checking base(03-12) - frequency checking range(03-11) ≤ outputting frequency ≤ frequency checking base

(03-10)+ frequency checking range (03-11)]

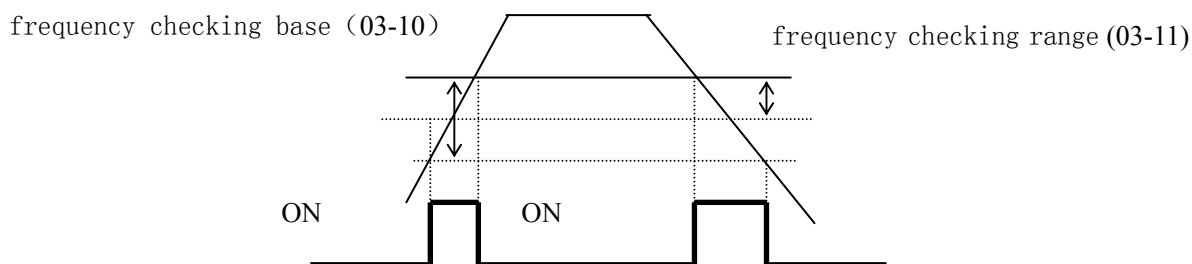

(b) bigger than frequency check (outputting frequency \geq frequency checking base)
 (set as "6")

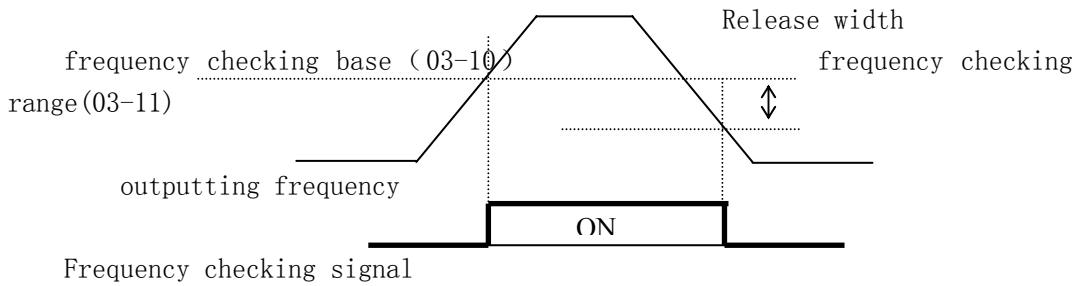

(c) less than frequency check (outputting frequency \leq frequency checking base)
 (set as "7")

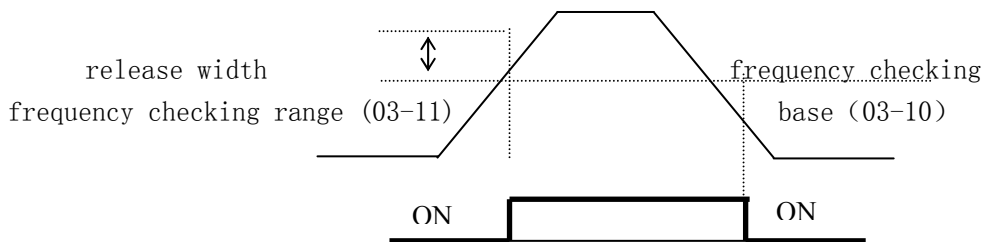

(d) reach the setting frequency (Set as "4")

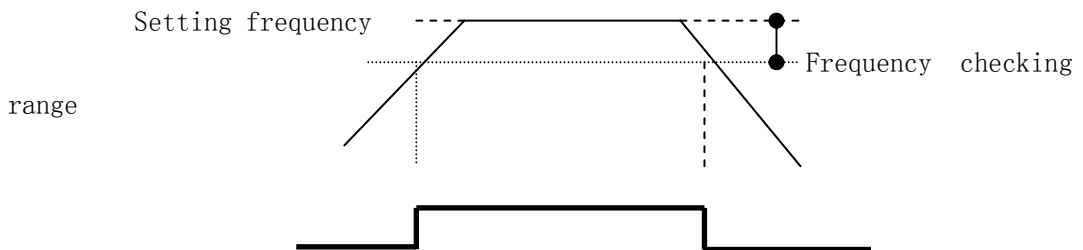

6-5、Input function

6-5-1、Analogue input

03-17 ~ 03-20 is to define the analogue signal and the setting value for the controlling terminal V2-GND (0~10V) and I2-GND (0~20mA) inputting.

★Note: While I2-GND input the current signal, 20mA corresponded 100% input value, V2-GND input voltage signal, 10V corresponded 100% input value.

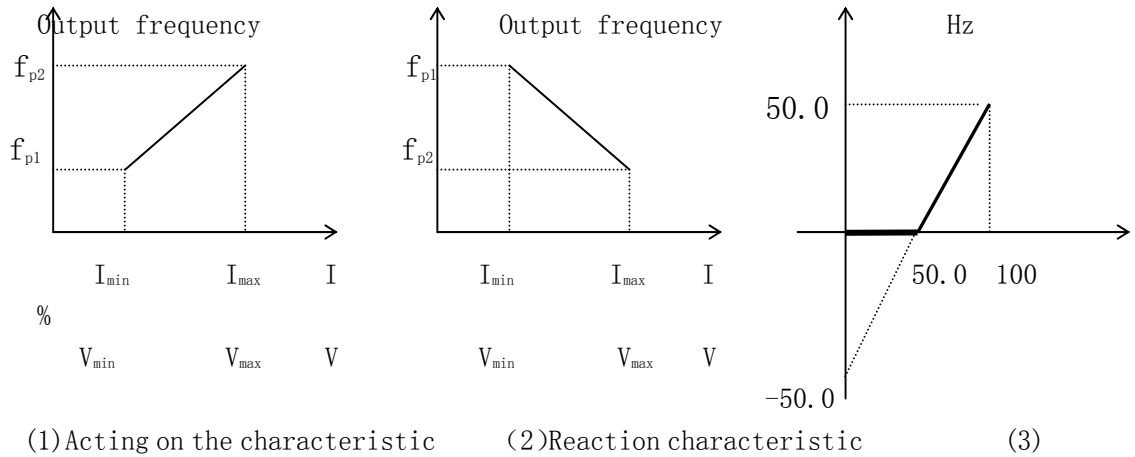

Min analogue input value refer to the minimal value of the input voltage or current, as picture of having shows V_{min} or I_{min} .

Analogue input setting bias refers to the min analogue value input the correspond setting data rate. as picture of having shows f_{p1} . (03-18)

The max input value refers to the biggest value of inputting voltage or the current, as the picture shows V_{max} or I_{max} .

Analogue input setting gain refers to the correspond setting rate of the max analogue value, as the picture shows f_{p2} . (03-17)

★notice:

- 1、 cording to 03-17 ~03-18, Can define two kinds of typical introduction and output the characteristic, as picture shows the action and reaction, these two characteristic can be used flexibly in control system with different feedback characteristic.
- 2、 In the closed loop control system that consist with the inverter and controller, must assure the systems action and reaction first then choose the output frequency characteristic of the inverter correctly.
- 3、 When analog signals use ing the frequency set. 100% correspond to the max output frequency. when analog signals use in given PI or feedback, 100% corresponds to the max feedback value.

Analog input type V2 (I2) choose (03-19)

Choose the input signal type.

Simulate input the filtering characteristic time (03-20)

Setting range: 0.1~10.0s

If the filter time is too long, will infect the adjustment. Deal the analog voltage or current signal that input with V2-GND and I2-GND with the filtering disposal to avoid the effects to system that cause by the disturbing signals change often. However, if the filtering characteristic time is too long may affect the sensitivity

Analog input reverse select(03-29): set analog input ~ output frequency beeline, the running mode of negative frequency as the picture (3) shows, real line

means negative frequency outputting is 0hz, broken line means the frequency is the reverse frequency order.

Example: While the single inputting is V2 with 0~10V outside, the adjust frequency range is 0.00Hz~60.00Hz, the max frequency input can be (01-10)=60.0Hz, the upper limit frequency (01-07)=60.0Hz, and the analog inputting type (03-19)=0,

Analog input bias (03-18)=0.0%, analog input signal plus (03-17)=100.0%.
Controlling terminal VF-GND (0~10V) and IF-GND (0~20mA) are the same as idem.

6-5-2、controlling mode of the terminal operating (02-17)

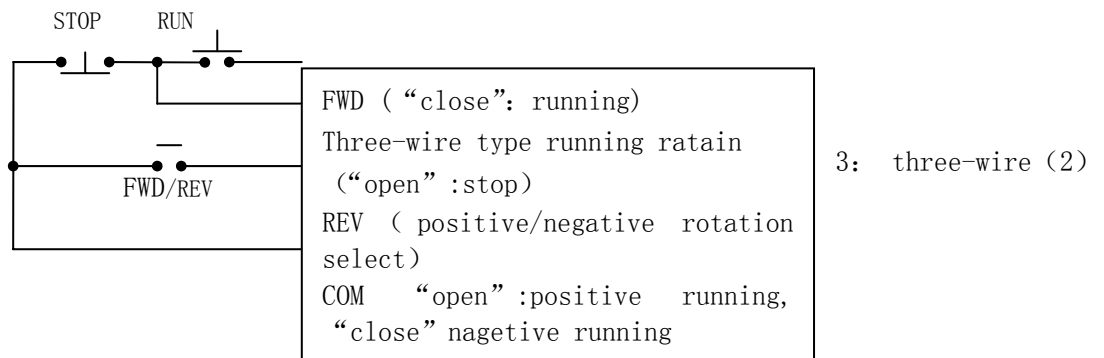
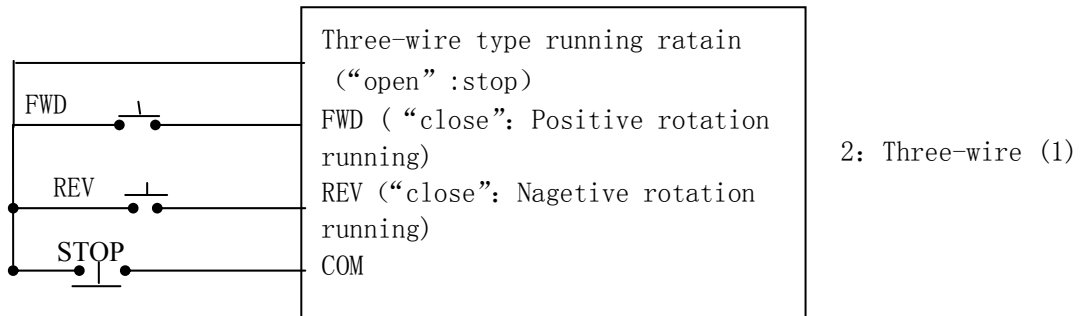
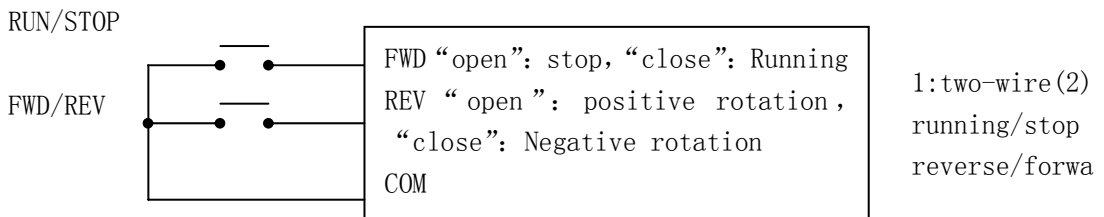
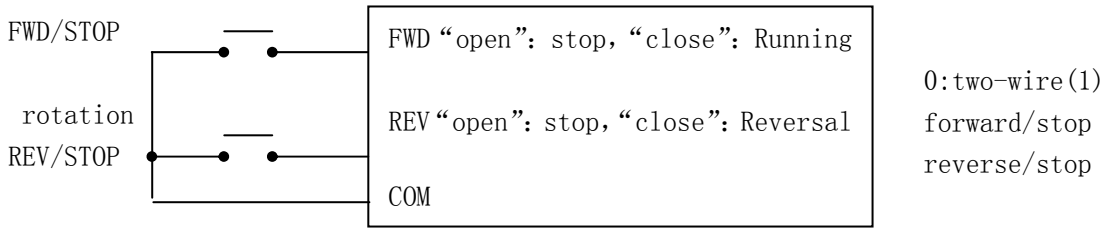

6-5-3、eletrify disposal terminal running select (02-19)

Factory data is 0,while connects power supply, dealing terminal input signal.example: while positive running order FWD input is effect,and while Terminal running ,connected the power supply,stat ppsitive ratation. ★while using ,take care!

Setting for 1 hour ,while connected,do not deal with the input singal.as the example mentioned ,not running ,only be connected after the FWD input break then can operate.

6-5-4、reset start mode select (02-20)

Set the function as 0, faulty happened, connect COM state in FWD(running state)press the reset button. The frequency inverter will be started and run automatically. At this moment, the contingency may happen, ask users to notice. If users start and run automatically immediately after not hoping to reduce, should set this function.

If users start and run automatically immediately after not hoping to reduce , should set this function as 1 . thus ,after reset give the OFF - ON to FWD, can the inverter start running.

6-5-5、crawl frequency (01-50)

Terminal crawl running select:

Establish the multi-functional input end son (D1-D6) in order to click and move and operate choosing.crawl running could accord the crawl frequency and second speed - down time . while more speed given and the crawl running choose input in the same time ,the crawl mode have the priopity.if adopt the terminal running mode ,while FWD terminal connected are for the positive crawl running .

Front panel running mode can chose the adjusting direction with the button **FWD/REV** And press **RUN** adjusting running ,speed-down and stop while off the button.

Name	Parameter mark	set
Second speed-up time	01-31	0.1~6000seconds
Second speed-down time	01-32	0.1~6000seconds
Crawl frequency	01-50	(factory set: 5.0HZ)
multifunction connect input select (D1-D6)	03-00, 03-01, 03-02, 03-03, 03-04, 03-05	any parameter can set to "11" crawl choose order.

Key board crawl running select:press **JOG button can turn the running mode to crawl running,at the same time ,the JOG indication light on.**

JOG Button is efficiency in running inspect mode only while the inverter stopped ,other wise will be inefficiency

6-5-6、multifunction input signal (03-00 ~ 03-05)

Multifunction connected input terminal D1 ~D6 can change with setting constant 03-00 ~ 03-05 while needed.

Terminal function D1: Set with 03-00

Terminal functionD2: set with 03-01

Terminal functionD3: set with 03-02

Terminal functionD4: set with 03-03

Terminal functionD5: set with 03-04

Terminal function D6: set with 03-05

set	Name	explain	Reference page
0	no	Inefficacy input	
1	Casade speed terminal one	Casade speed input order	46
2	Casade speed terminal two	Casade speed input order	
3	Casade speed terminal three	Casade speed input order	
4	Upper frequency order	Increase output frequency while closing	44
5	Down frequency order	Reduce output frequency while closing	
6	Faulty reset frequency	Inverter fault while closing	
7	Abnormity outside, ordinary open terminal input N.O	Inverter stop for fault while outside fault signal input close. If the output break, numeric operate show “EF” .	
8	Abnormity outside, ordinary open terminal input N.C	Inverter stop for fault while outside fault signal input close. If the output break, numeric operate show “EF”	
9	Secondly select time for speed-up and speed -down	Speed-up time choose	31
10	Free stopping order	Inverter stop output while closing, the machine stop itself.	
11	Crawl running sekest	Choose adjusting running mode while closing.	42
12	Three-wire running control	Three-wire running keep input	41
13	Rigister input terminal	Exterior counter output teminal	45
14	Eliminate rigister	Counter count value reset	
15	Timer input	Exterior timer input	43
16	Program run pause	Program operate pause operating input	
17	Forbid speed-up or speed-down order	Inverter output frequency donot change	44
18	REF1/REF2 frequency	Choose REF2 frequency setting while	

	change	closing	
19	Front panel run order	choose front panel operating mode while closing	
20	PI control cancel	Cancel PIcontrolling mode while closing	
Other	Reserve		

6-5-7、 Timer function (03-15,03-16), multifunction input terminal, output terminal setting for timer function.

While the connecting time of timer function is longer than ON-delay timer (03-15), the timer function output is connected.

While input “open” time is longer than OFF-delay timer, the timer function output will brake off.

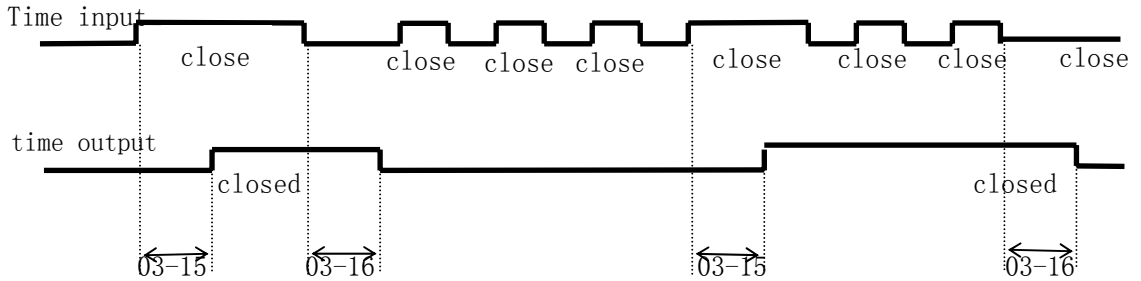

6-5-8、 Forbid the speed-up and speed-down order (Multifunction input terminal setting :17)

If input and forbid adding it while moderating the order, output frequency and keep intact, after inputting the order of shutting down, enter the state of shutting down.

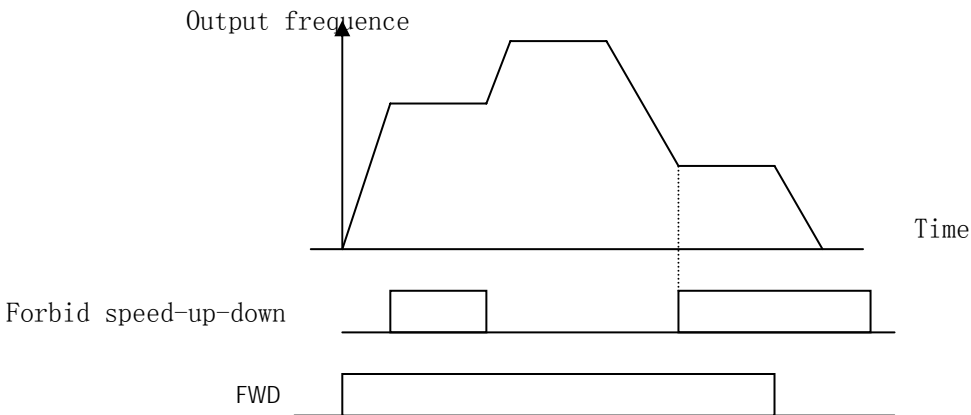

6-5-9. UP/DOWN order (setting: 03-00, 03-01, 03-02, 03-03, 03-04, 03-05=4, 5)

While input the positive (negative) running order, the terminal input UP/DOWN

can change the frequent order.make it running in expecting speed.

Set D5 as UP (03-04=4), D6 as DOWN (03-05=5)。

Curcuit controlling terminal D5 (UP order)	Close	Open	open	close
Curcuit controlling terminal D6 (DOWN order)	Open	Close	Open	Close
Running state	Speed-up	Speed-down	Retain	Retain

Time picture of inputting UP/DOWN order as following:

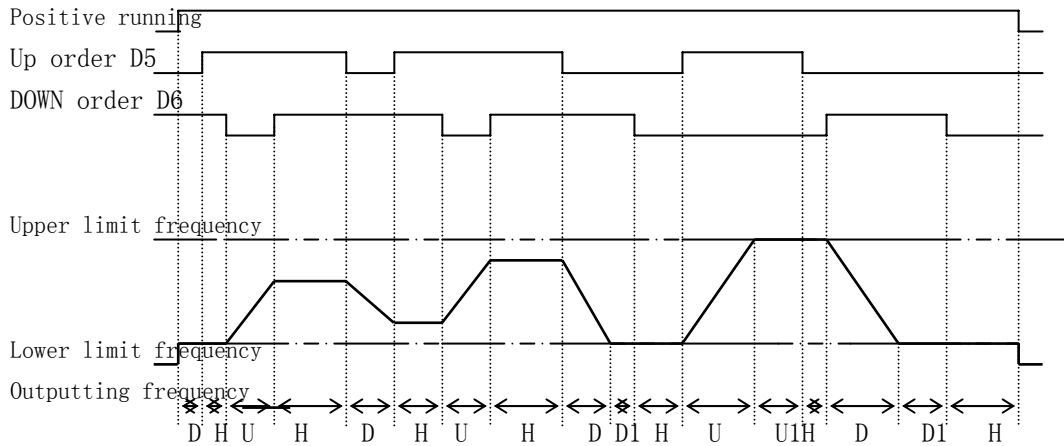

Arrive setting frequency

Ralay signal

U=UP (speed-up state)

D=DOWN (speed-down state

H=HOLD (retain)

U1=UP state (on upper-limit value steadily) D1=DOWN state (on down-limit value steadily)

★ **notice:**

To choose orderUP/DOWN, the outputting of inverter are limited by upper-limit frequency .

6-5-10、Counter function (03-13, 03-14, multifunction input terminal set for counter)

03-13 Set the timer setting value, 03-14 set the max value of counter.

This parameter set the inside tally value of CS3200, outside terminal which on the controlling loop can be the tigger terminal for counter.while count value reach to 03-13setting value, the appoint signal “counter reach to setting value RELAY output” connecting action.

While count value from 01 up to the max value of 03-14 counter, the corrspond “counter to the max RELAY output” multifunction output terminal tipper action. The parameter can be used afer the counter finishing, and before stop, the output signal can make inverter in low speed till stopped.

Sequence stoped as follows:

Show value

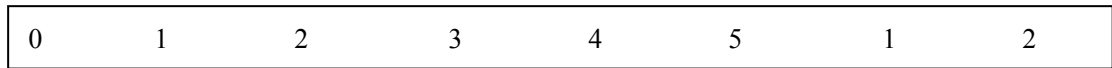

Counter tigger signal

width of tigger shouldn't

counter setting value (03-13=3)

under 20mSec (<25Hz) signal

arrive output (03-06~03-09=11)

counter max value (03-14=5)

arrive output (03-06~03-09=12)

6-6、Cascade speed and process running

6-6-1、Choosing of Cascade speed

With frequency order and multifunction conneection input combination, can set 8 step speed at most.

(03-00, 03-01, 03-02, 03-03, 03-04, 03-05) set for cascade speed order.

[Speed1, Speed2, Speed3]

To set D1, D2, D3 terminal as "speed1" "speed2" "speed3", the inverter can be running in perinstall speed.

The D1, D2, D3 terminal combination decide the cascade speed.

Step frequency	Parameter code	Speed 3 (P3)	Speed 2 (P2)	Speed 1 (P1)
Main frequency	01-01 set	0	0	0
Cascade speed 1	01-39	0	0	1
Cascade speed 2	01-40	0	1	0
Cascade speed 3	01-41	0	1	1
Cascade speed 4	01-42	1	0	0
Cascade speed 5	01-43	1	0	1
Cascade speed 6	01-44	1	1	0
Cascade speed 7	01-45	1	1	1

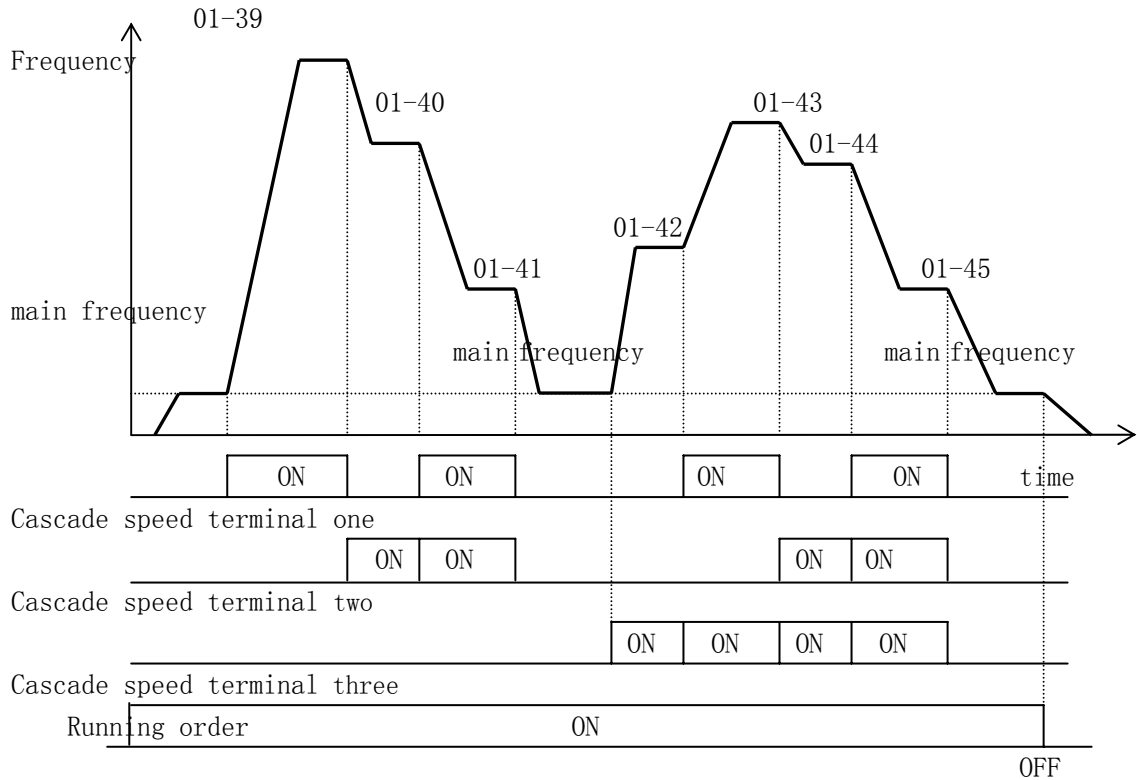

6-6-2、Process running

Process running is running frequency, running time, running direction, speed-up and speed down time, and the running model can programme cascade speed timing running.

Process running mode choosing (04-00):

0: Process running mode inefficacy 1: Process running circle

2: Process running sopped after one circle 3:after one circle, running in last speed.

The application of this parameter can be controlled as general small-scale machinery , food processing machinery , working procedure washing the equipment. can replace the conventional relay switch and timer controlling line; Relevant parameters establish a lot of while using this function, the mistake that every detail can't , please consult the following explanation carefully.

Running speed of process

- 01-39: Cascade speed 1
- 01-40: Cascade speed 2
- 01-41: Cascade speed 3
- 01-42: Cascade speed 4
- 01-43: Cascade speed 5
- 01-44: Cascade speed 6
- 01-45: Cascade speed 7

★The parameter can set while running , can set to negative value, The electrical machinery operates backward

Direction setting of process running:

Directions setting is decide by polarity of cascade speed

Time of process running

04-04: First step running time setting

04-05: Second step running time setting

04-06: Third step running time setting

04-07 Fourth step running time setting

04-08: Fifth step running time setting

04-09 Sixth step running time setting

04-10 Seventh step running time setting

The setting time of seven parametr is to work in process running ,and the max value of parameter is6000.0 seconds..

★Explain in particular:

If the setting value is 0.0(o second), Representing this stage will operate and will be omitted and jumped to the next stage and carried out automatically. Though CS3200 series offer to can is it run to programme seven sections of speed, user can to use need that pay still, reducing the procedure and operating it for five stages, three stages, etc., the stage that the choice of movements will not only want to carry out sets as 0. 0 (0 seconds) can use it freely.

Procedure operation adds and moderates time to choose

04-11~04-17、Add and moderate time to choose 1~7

Whom the above-mentioned seven parameter select is it moderate time to cooperate with procedure is it run every stages to operate to add.

1: Add and moderate time 1 2: Add and moderate time 2 3: Add and moderate time 3

4: Add and moderate time 4

Example one: After the procedure operates a cycle, in the last section of examples that speed operates

Action explain

Left pursuing to show, as the operation order of the procedure is reached, the frequency inverter runs according to the settlement of every parameter, continue running in the last section until the seventh section is finished, until operation order OFF did not stop

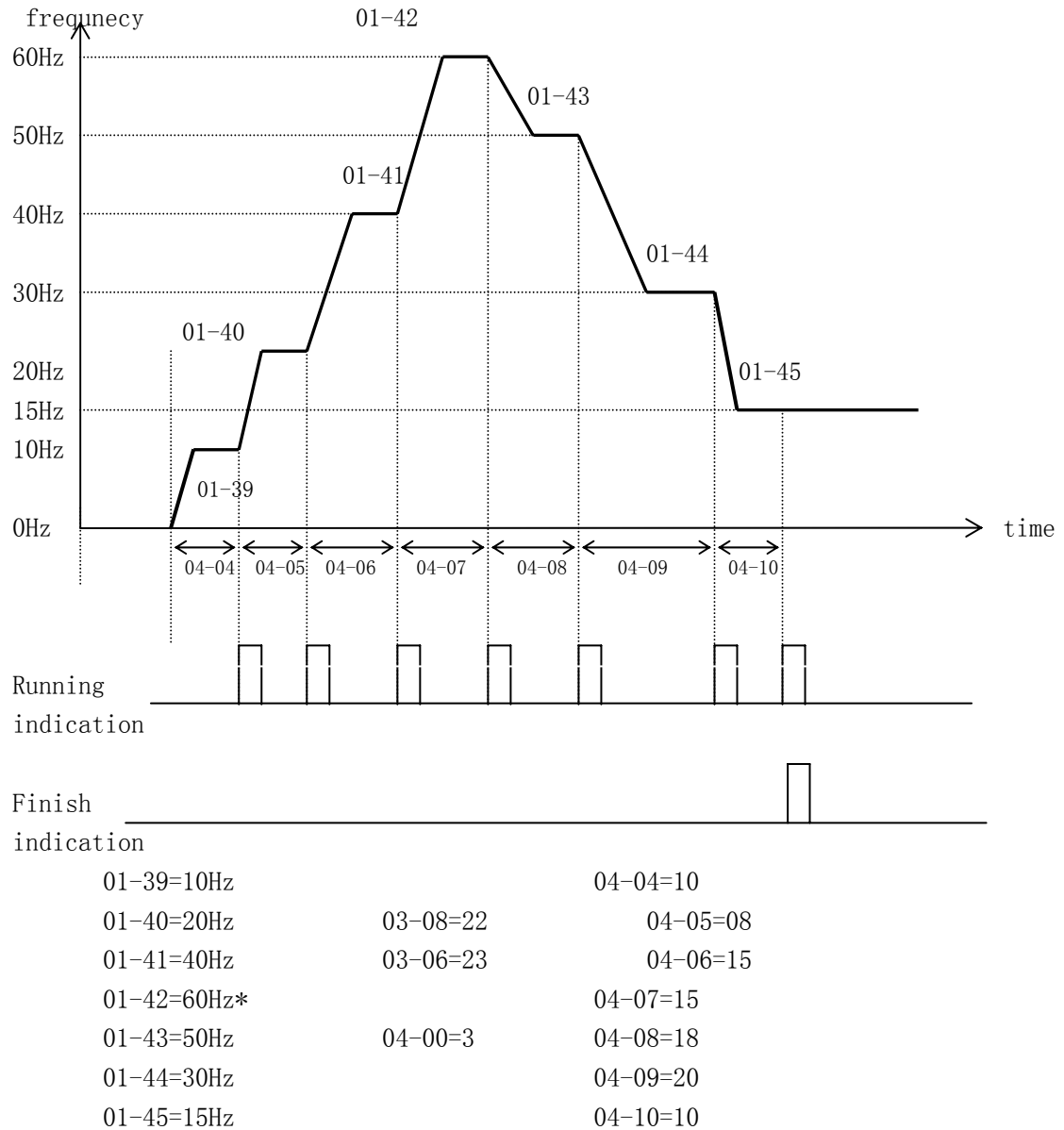

Example two: process running in circle

Action explain:

Left pursuing to show, as the operation order of the procedure is reached, the frequency inverter runs according to the settlement of every parameter, get back to first section of tempo more and continue running in circulation until the seventh section is finished, until procedure operation order OFF did not stop.

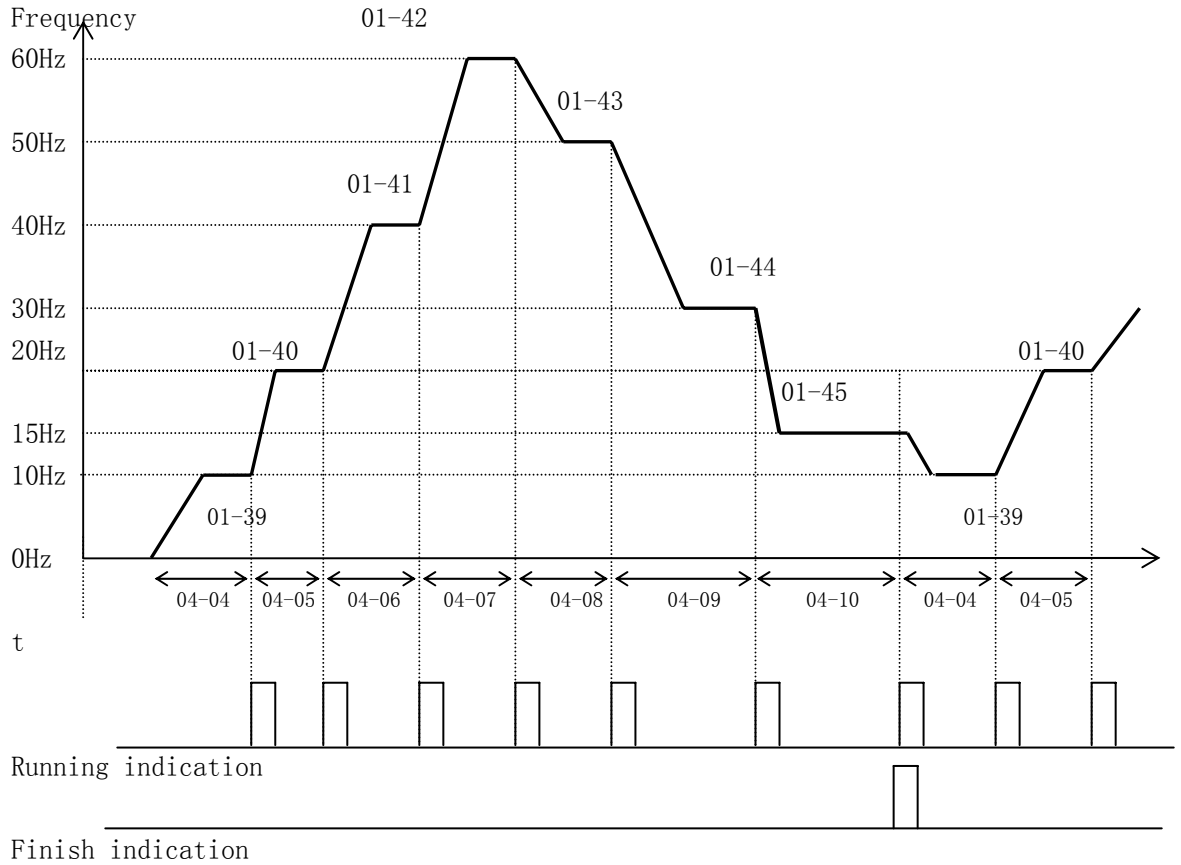

01-39=10Hz		04-04=10
01-40=20Hz	03-08=22	04-05=10
01-41=40Hz	03-06=23	04-06=15
01-42=60Hz*		04-07=15
01-43=50Hz	04-00=1	04-08=15
01-44=30Hz		04-09=20
01-45=15Hz		04-10=22

Example three: stopped after one cycle
 Actions explain: set negative speed, running reverse.
 Pursued to show, when choosing the operation way of the procedure, the frequency inverter runs according to the settlement of every parameter, stop automatically until the seventh section is finished. Is it start again to want, order OFF ON and then of operation

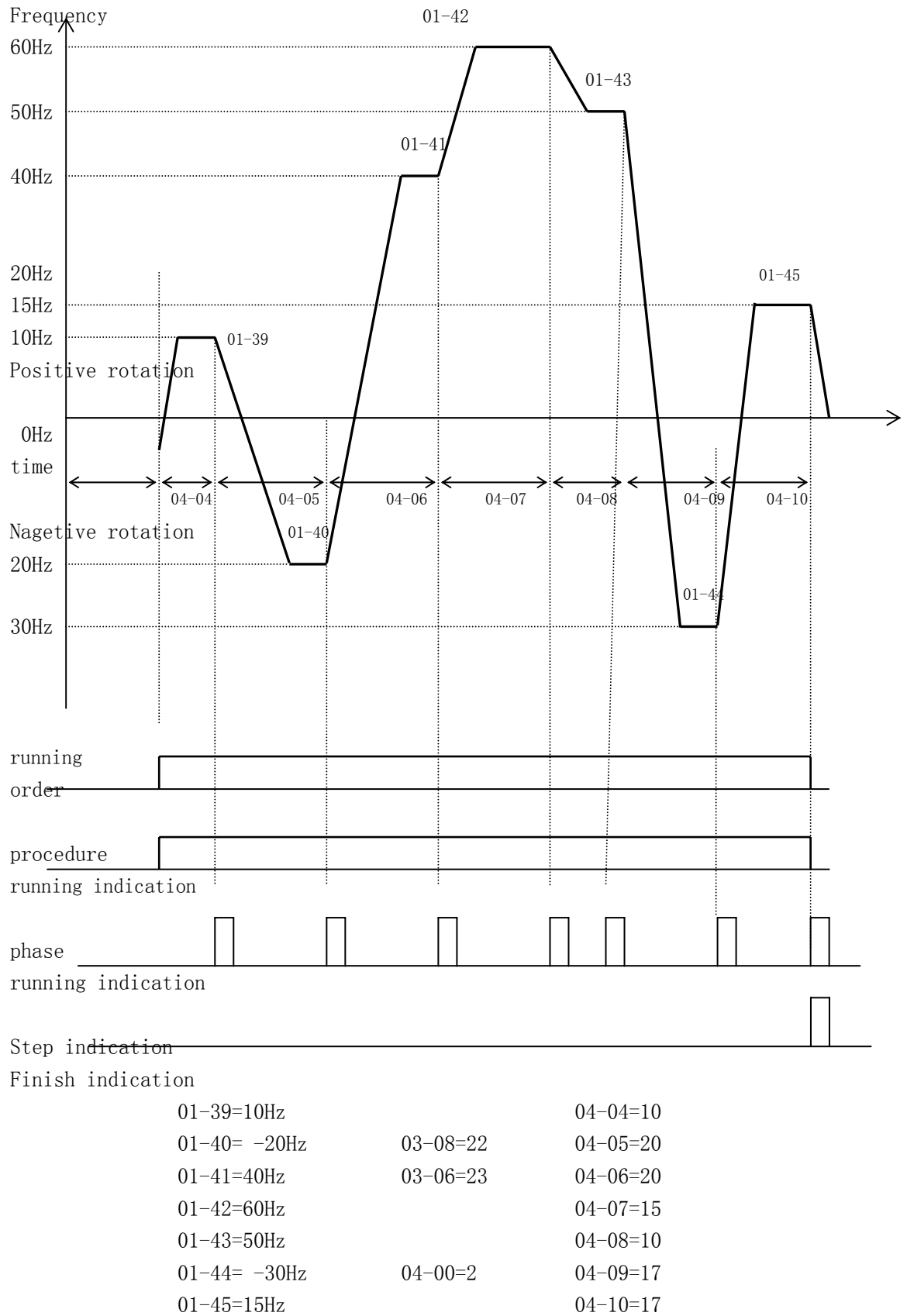

6-6-3 Wobble running

Wobble running mode is fit for spin printing and dyeing.

wobble mode (04-18) 0:Inefficacy 1:efficacy

wobble amplitude value f_h (04-19)

difference frequency Δf (04-20)

risetime T_1 (04-21), droptime T_2 (04-22)

according to T_1, T_2 parameter to count the speed-up and down time, setting frequency should be higher than f_h .

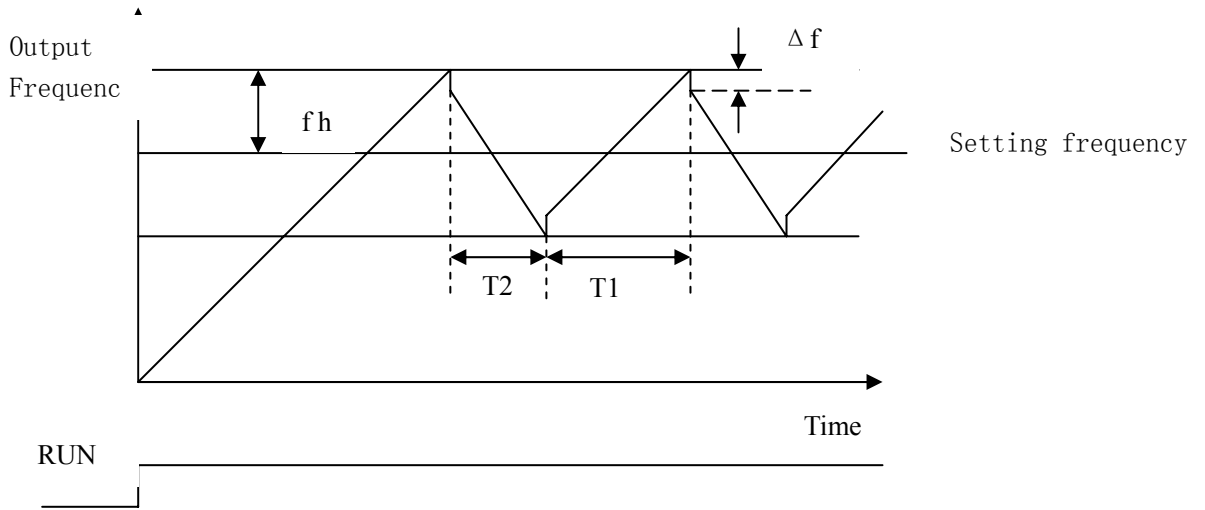

Running picture

6-7、PI controls parameter

6-7-1、Outside V2 given value (03-17, 03-18)

While PI given signal choose (05-02) =1, outside V2 preset

If as it is 0 that outside V2 inputs the voltage. 0V hour, the setting value is -10.0%; when V2 input voltage is 10.0V, the setting value is 50.0, Can establish like this: 03-18= -10.0, 03-17=50.0。

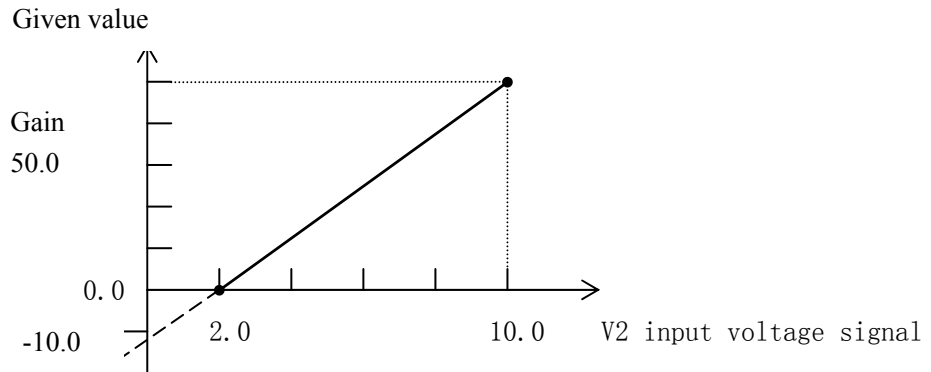

6-7-2、 Outside IF feedback value(03-21, 03-22)

While PI feedback signal choose (05-04) =2, using feedback IF outside.

If IF outside is 4mA, the pressure is -10.0%; if IF is 20mA, the pressure is 50.0%.

Setting 03-22= -10.0, 03-21= 50.0, any two points correspond to one line.

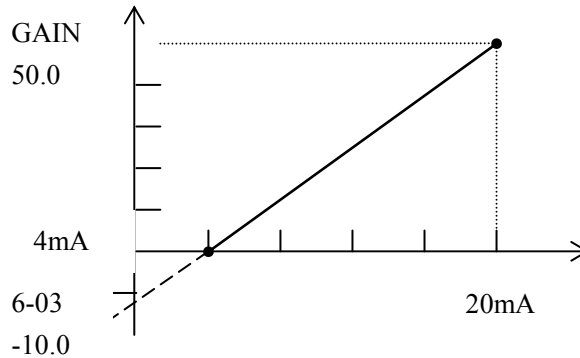

6-7-3、 Feed back filter time (03-24).

Deal the VF (IF) input signal with filter. Avoid disturbing signal affect the system. While the filter time is too long may affect the sensitivity of the system.

6-7-4、 PI regulate error polarity (05-01).

Normal polarity, when the feedback value decrease, PI output frequency increase, 05-01=0.

Negative polarity, when the feedback value decreases, PI output frequency decrease 05-01=1, error value uses oppsite.

6-7-5 PI regulate mode min running frequency (05-09).

Frequency injuction is 0, through PI regulating. If some systems donot promise stopping then set the 05-09 larger than lower frequency 01-08.

6-7-6、 PI regulate mode max running frequency (05-10).

SETS PI the max output frequency of the adjuster.

6-8、 protect parameter

6-8-1、 Over-voltage lose speed protection (01-29).

In inverter speed-down running process, because the effect of the load inertial, may may cause actual rate of decline of the machine rotational speed lower than rate of decline of the output frequency. Then the machine will feed back the power to inverter, cause DC generatrix voltage increase. If donot take measure, may cause over-voltage trip.

Over-voltage lose speed function choose (01-29) 1, over-voltage lose speed prevent function is in effect.

Over-voltage loses speed point: 200v degree is 390-410v, 4000v degree is 780v-820v.

Over-voltage lose speed protecting function is in inverter speed-down running process through check the generatrix voltage and compare with lose speed over-voltage point. If exceed the comparision point,make the inverter output frequency stop descending.when check generatrix voltage lower than the standard value then use speed-down running,show as below:

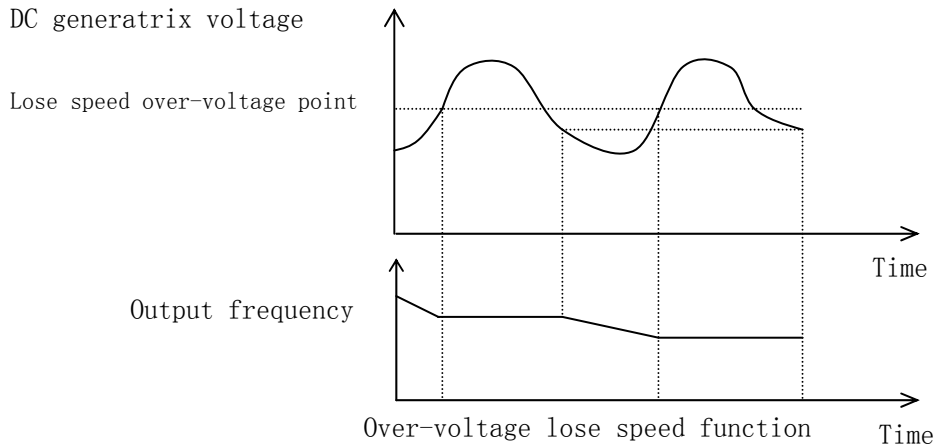

6-8-2、Dynamic braking chose (06-06) .

0: None

1: Safety mode: only in inverter speed-down process, check the AC generatrix voltage exceed the reserve value complete the dynamic braking.

2: General mode: inverter at any station. If check the generatrix voltage exceed the reserve value complete the dynamic braking.

When the inverter running in the irritated reduce the speed station, may happen over-voltage or over-current. The phenomena may happen easily when the load inertia is large raletively.when the DC generatrix voltage exceed a certain value that checked in the inner, the output brake signal achieve the dynamic braking through the external connection braking resistor. The consumer can choose the machine type that has the braking function to apply this function.

6-8-3、automatic voltage regulate AVR (01-16)

0:none 1:Yes. factory value is 1, the automatic voltage regulate (AVR) function is in effective.

When AVR function is effective, input voltage fluctuate to some extent, can is it output voltage keep for the setting for value basically to make, make electrical machinery work in the original state.

6-8-4、Current limiting (01-27)

Over-current lose speed set (01d-28), setting range: 20~180%.

When the frequency inverter is carried out and accelerated , because it is too fast to accelerate or the motor is too big in load, the frequency inverter will rise rapidly if the frequency inverter exports the electric current, exceed the establishing value of 01-28 (cross the stall of the electric current and click) ,

the frequency inverter will stop accelerating (keep regular to output frequency), when the electric current should lower than the establishing value, the frequency inverter continues accelerating

If frequency inverter in running constantly, output electric current exceed 01-28 (pass electric current stall a bit) when the person who establish, the frequency inverter will reduce the frequency of outputting, avoid the stall of the motor. If it is lower than 01-28 establishing value to export the electric current, then the frequency inverter accelerates to establishing frequency again. Percentage is established to establish the unit and output the electric current (100%) with the amount of the frequency inverter.

lose speedover voltage
current check out
location (01-28)

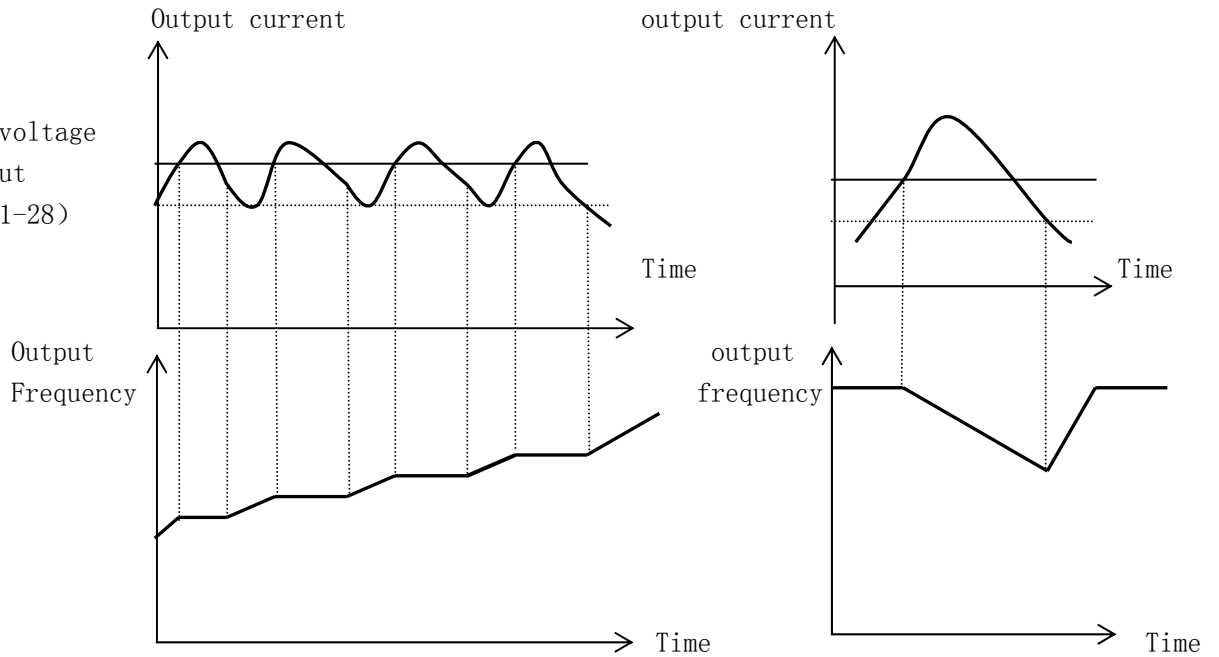

In accelerating, over current current lose speed prevent function.

Constant speed running, over lose speed prevent function.

6-8-5、 Over torque checking

If overweight loading adds to machine device, the increase of the output current can be checked by outputting the warning signal of the multifunction terminal. To output the over torque checking signal, the multifunction connection outputting choosing as overtorque checking.

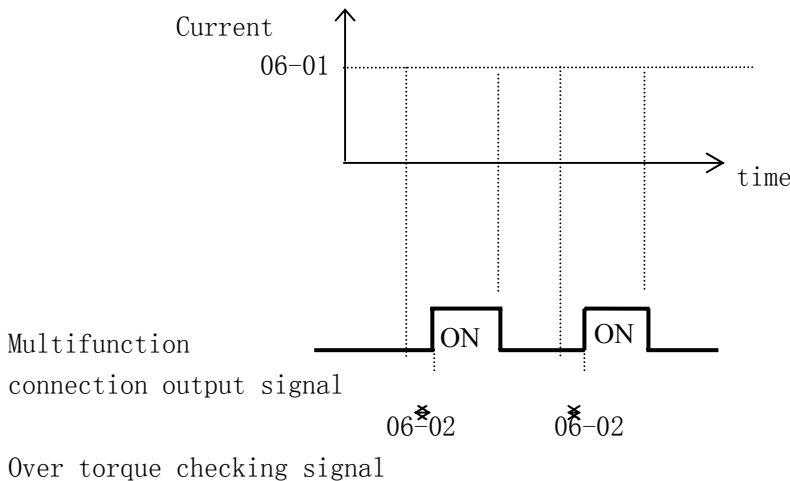

(a) over torque checking function for choose (06-00)

Set	Explanation
0	no checking (factory setting)
1	Checking betwwen constant speed running, and continued running after checking.
2	Checking between running ,and go on running after checking
3	Checking while in constant speed, inverter output stopped while over torque.
4	Checking while running, inverter output stopped while over torque.

1. Setting to 2 or 4 to check over torque while speed-up or speed -down.
2. To continue running after checking over torque, the exerciser display “oL3” warning (blink) while set as 1 or 2.
3. To stop inverter outputting while over torque, set as 3 or 4, will the exerciser display “oL3” (blink).

(b) Over torque checking norm. (06-01)

By 0. 1% of the units have established the electric current datum that the torque measure . (rating inverter current: 100%).factory setting: 160%
 If set the over torque checking as 0. 0%, the checking function will be inefficacy.

(c) Over torque checking time (06-02)

If machine current time which go beyond the over torque checking base (06-01) longer than torque checking time (06-02), the over torque will check the function action. Factory setting: 0.1s
 While inverter output current last exceed the over torque base (the rating current is the basic value) and the setting time, the inverter will waring and stop running, to protect the inverter while at the same time monitor the loading faulty.

6-8-6、Machine protection

Machine overloading checking

Can protect the machine by using the electron inside inverter, exact setting as follows:

- (a) Thermal overloading protecting level can be set by rating current of machine and inverter.
- (b) Machine overloading protection for choose in fg(01-24)

Set	Electron thermal character
0	No protect
1	Standard machine (factory setting)
2	Conversion machine

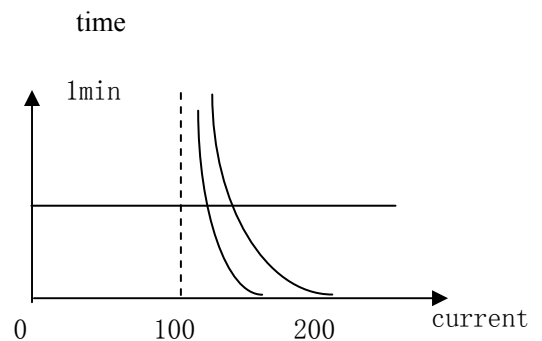

The electron overloading protecting function is according to the inverter output

current, frequency and the analog time to scout the temperature of elctormotor, protect the elctormotor to be overheat, while be the overloading relay action, display “ oL ” faulty signal, to cut off the inverter outputting, prevent elctormotor to be overheat .while inverter connected to run with a elctormotor, no need with an outside hot relay. while one inverter running for several elctormotor s, a hot relay should be installed in every elctormotor, and in this case, set the constant 01-24 as 0.

(c) Standard elctormotor and inverter special electromotor.

Induction motor is divide to standard and convert motor according to their cooling ability, in other words, the analog character is different of the inverter overheat loading prection temperature.

	Cooling effecton	Chracter	Heat overloading electron
Standard electron motor	at commercial power 50/60Hz running will be effect in cooling.	In low speed running, course the motor temperture rising should limited the load.	While continuous running in 100% loading low speed will be the heat overloading pretection.
Inverter special motor	Even in lower speed (about 6Hz) running will be cooling.	To be running in low speed, use the inverter motor.	In 100% loading, 50/60HZ or the lower speed running continous, the electron heat over load protection do not act.

6-8-7 、 reset time for faulty. (02-07)

The inverter reposition and reset time to set, the max can be 10 times.

The inverter can reset automatically after happed the faulty.

- .oc (over current)
- .ou (over voltage)
- .Lu (under voltage)
- .Grd (grounding faulty)

Reset time will resume to the setting value in the case followes:

- 1、 If no other faulty happened after tautology which in the time reset and resume.
- 2、 The power supply cut off.
- 3、 Reposition in handle after faulty.

6-9、other function

6-9-1、Instant power cut reset choosing (02-11) .

After instant power fail, running freely. after resume the power, can choose whether to reset.

0: no running 1*: the under voltage time no longer than (02-12) After the voltage resume, restart.
--

While in outside controlling, should retain running order to resume from instant power cut and continue to run.

While 02-12 set as 0.0, it will not limited by power cut, and after voltage resumed, all of it could restart.

6-9-2、persure the starting mode (02-13)

Rev persure the starting choose:

0: After inverter faulty or persue start after free stop.

1: Persue start in any case of inverter

2: Persue start is inefficiency.

To running over again without stopping the free slipping motor, should start speed select order to persue start (needs to use DC brake function if the motor reset after stopped 02-13)

Speed select order:

Persue to start the motor, which is, haven't stopped slipping, and the function will make the motor start steady.

The persue start time pictures are as follows:

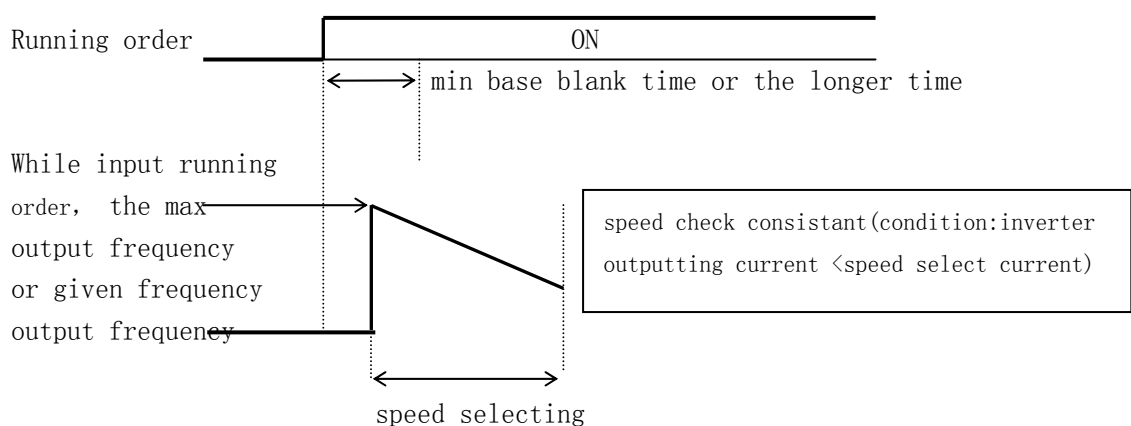

speed selecting (condition: inverter outputting current \geq selecting current)

6-9-3 Skip frequency (01-46, 01-47, 01-48, 01-49)

This function would forbid or "skip" critical frequency, turn away the resonance evocabled by machine system in running the motor. the function will have no effect

while setting value is 0.0HZ

Output frequency

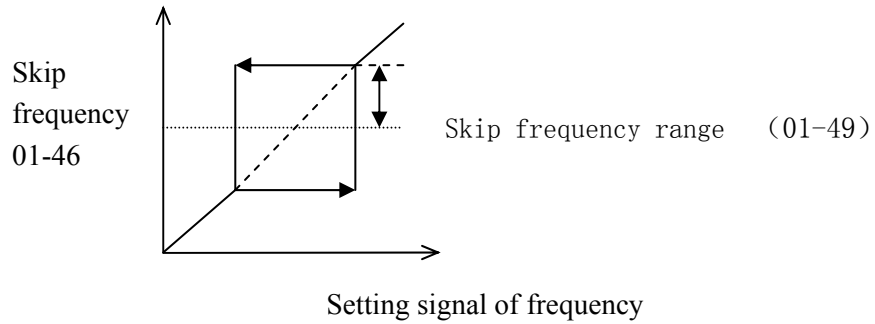

6-9-5、(01-14) automatism torque compensation

The torque requirement of the motor changes according to the load situation, but according to the voltage of load torque requirement automatic V/f way. The necessary torque is calculated by the frequency inverter, this has guaranteed that can not trip to operate

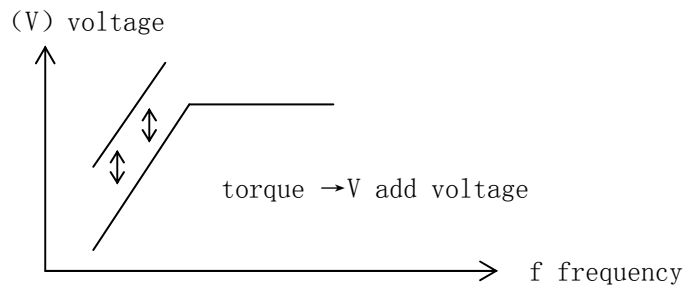

6-9-6、Energy saving control (01-30)

To save energy, set energy - saving control as:

Set	Explain
0	Invalid to control
1	Effective to control

★ energy - saving control can be effected in constant rate, suit for steady loading state. This function may be caused and run unstably when load changes very big.

6-10、To control with RS-485 message.

While frequency set mode is 01-01=5 or running order choose 01-00=2, epistasy machine or MPU can be used with the most 31 inverters to serial transmitted. The main control and been controlled signal transmitted is the main control all

along, and the been controlled respond to it, the main controlling and the been controlled device to transmitted signal. so should should assign the address NO. (08-00) to every controlled device previously, and the main controlling transmitted according the address. the controlled device received the main control order and perform the function, and return answer to the main control.

6-10-1、Message parameter setting:

08-00 Message adress

1 ... 31

Define the device adress. while on line do not allow two devices to use the same adress, and the adress 0 is broadcast adress. 1 ... 31

08-02 transfer brakeout check time .

Setting range: 0 - 60 sec

Communcation between inverter and cumputer, if one is no answered and displayed cE error to urgent stop running within setting time .if set as 0, the function will not be performance.

6-10-2、communacation spec

Interface: RS-485

Synchronizing system: asynchronization

Transfers parameter

baud rate: choose from 1200, 2400, 4800, 9600, 19200 (parameter **08-01**)

Stop position; fixup to 1 position.

The device number that can connected at most; 31 devices (while using RS-485)

7、Faulty remove.

Maintenance and checking



Warning

- **Do not touch high voltage terminal inside inverter**
If not obey will lead to electric shock.
- **should install all the protect cover over again before the current electrify**
If not observe, might lead to electric shock.
- **After the loop cut off, can maintenance and check after discharged.**
Electricity full in capacity ,will lead to danger.
- **allow specialty person to maintenance or to change parts.**
(lay down all the metal arecles like watch and bangles)
(Use the pressurerization and prevent insulated tool.)
If not observe, might lead to electric shock.

- In running scout mode, while happed fault and warning ,will display the signal of fault and warning .
- If the indicator light of the inverter FLT on,means happened fault.
- If disappear the fault,press the **RESET** to reposition .
- If happened the serious fault, should cut off power and reset.
- If fault haven' t reset or clear up the screen, the keyset will display the faulty code all along (refer to fault diagnose)
- Users can press **ENTER** to clean up the screen, and the fault haven' t reset.
- Notice! If the fault sttil in within press in 10 mins, the fault code will display on front panel.

Press kye-press reset, and can set the multifunction data input terminal to be the fault reset, and connected the terminal, or to use RS485 communcation, the fault can be reset after power cut.

7-1、Fault diagnose and correct measure

Display fault	Instruction	Detail	Put right
Lu	lack of voltage in main loop (PUV)	Lack of DC main loop voltage in running period. Check level: 200V step about 190VDC or Lower. 400Vstep about 380VDC or lower 660V step about 700VDC lower	<ul style="list-style-type: none"> ◦ Check the power line ◦ Correct the lead-in voltage
oc oc1	over current (OC)	Output current exceed the OC Value.	<ul style="list-style-type: none"> ◦ Check motor loop resistance ◦ Delay the time speed up and down ◦ Check insulation of motor ◦ Check within universal meter
ou	over voltage (OV)	Main loop DC current exceed setting value. Check level 200V step: about 400VDC 400V step: about 800VDC 660V step: about 1300VDC	Delayed the time speed down, and add to brake resistance
Grd	Ground fault (Grd)	Output grounding current of inverter overrun the 50% rating current	<ul style="list-style-type: none"> ◦ Check having bad of insulation or not ◦ Check if have broken connection between inverter and motor
oh	Over-heat of radiator (oh)	radiator temperture \geq oh check value (about 80°C, come from temperture swtich)	Check the air blower and environment temperature radiator and ventilate the state, remove the dirt
oht	radiator Over-heat (oht)	radiator temperture \geq oht check value (about 90°C)	
ol	motor over loading (oL)	inverter output exceed the motor over loading value	Reduce loaging
oL2	inverter over loading (oL2)	Inverter output greater than overloading valur	Reduce loaging, and delay the time speed up
oL3	over torque checking (oL3)	Output current exceed the checking value of torque	Reduce the loading, delay the speed up time.
ocP	loading curreent short circuit (oCP)	Inverter output (loading) short circuit	<ul style="list-style-type: none"> ◦ Check the motor loop resistance ◦ Check motor insulation

<i>EF</i>	exterior fault (EF)	Trouble that the outside control circuit produces	◦ Check current exterior control
<i>SPi</i>	Generatrix converges and arranges and has the voltage to fluctuate too big (SPi)	Have lack-phase inverter input power supply Have no balance inputting voltage.	◦ Check lead-in voltage ◦ Check electric motor impedance ◦ Rescrew the input terminal bolt
<i>SPo</i>	outputting lack-phase (SPo)	Have lack-phase of outputting conversion	◦ Check outputting connection ◦ Check motor impedance ◦ Rescrew outputting terminal bolt
<i>LL</i>	under loading protection (LL)	Electric motor load losing	◦ Check motor and load connection
<i>EEP</i>	eeprom fault (EEP)	Fault in inverter controlling unit	Resume factory value, amend needed function, if still have problem should change the control board and card
<i>ErP</i>	parameter setting fault (ErP)	Setting value exceed range	Idem EEP
<i>cE</i>	RS-485 communicate error (cE)	Communicate data make mistake or no answer	communicate interface circuit or communicate signal
<i>Lo2</i>	V2(I2) signal losing Lo2	Signal losing beyond a given time	Connected the line
<i>LoF</i>	VF(IF) signal losing LoF	Signal losing beyond a given time	Connected the line
<i>Lo3</i>	VX options Connected the line Lo3	Signal losing beyond a given time	Connected the line
<i>Er5</i>	Current error inside (Er5)	checking current error of inverter	Resume to power after cut off, if problem still, should change control board.
<i>Er6</i>	Rating current setting too big (Er6)	Exceed rating current of inverter	While motor capacity over size, set the rating current.
<i>oPr</i>	Front panel communicate fault (1. oPr)	Have mistake in communication of front panel and inverter.	Key board interface current or connect line

7-2、 Warning display and explain

Warning would not stop running, and have no output action, and after clear up the fault can be the inverter back to the running state again.

The various different warning explain as follows

Warning display	Content	Explain
oFF oFF blink	Undervoltage checking	Check out under voltage
oH1 oh1 blink	Raditor overheat	raditor temperature \geq Oh1 to choose oh1 warning and go on running in checking base (about 80°C)
oL oL blink	Electric motor over load warning	Load of machine beyond the warning level
oL2 oL2 blink	Forecast warning of overloading inverter	Load of inverter exceed the warning level
oL3 oL3 blink	Check cross torque	While output current of inverter >06-01(cross the checking base of torque), corss the torque checking and go on running.
dcbr blink	DC brake indication	
dchL dchL blink	DC brake indication while start	
AL1 AL1 blink	Set error while lock up the parameter	
AL2 AL2 blink	Do not set parameter while running	
AL3 AL3 blink	Parameter can not set in nonce step	
AL4 AL4 blink	Setting value exceed the range	
Loc Loc blink	Lock up the state of terminal running	Reclosed the outside order after brake.
noAc NoAc blink	Ratain parameter	

7-3、 Motor accident and corrective measure

If produced any trouble the following in the motor, check its reason and take the corresponding measure of correcting.

If these can't solve the problem to check and correct the measure, please get in touch with agent immediately

Motor accident and corrective measure :

accident	Check signal	Corrective measure
The motor can' t running	Whether the voltage of the power adds in the end son of R、 S、 T?	Open the power ; Chose the power and through again; check the voltage of the power ; make sure the end of scree has firmed .
	Measure sub U of output end with the rectification type voltmeter, V, is the voltage of W correct	Chose the power and through again
	Makesure whether the overload, the motor is locked?	Reduce load and get rid of locking.
	Whether show on the operating device display that cranky?	Check the trouble according to the fault dictionary
	To or reverse operation order input?	Check wiring
	Whether it has introduction that frequency establishes the voltage?	Correct wiring, frequency and establish the voltage
	Whether the settlement of the operation way is correct?	makesure input and establish is correctly
The motor changes direction oppositly	Sub U of end, V, the wiring of W is correct?	With motor lead wire U, V, the looks preface of W is wired correspondingly
	Makesure whether operation input signal that FWD or REV join is correct?	Check wiring
The motor is rotately but can't change speed	Frequency is given definitely is the wiring of the circuit correct?	Check wiring
	makesure whether the settlement of the operation way is correct?	Using the exerciser to check the choose of running model
	Whether load is too big?	Reduce load
The rotational speed of the motor (rotates / divides) is too high or too low	Motor specified for value (count very much, voltage) the correct	Check the motor data plate technical data
	It is correct that gear wheel, etc. are added / moderated the gear ratio?	Check and change speed in the organization (gear wheel, etc.)

	It is correct that the most greatly to output the frequency establishing value?	Check and output the frequency establishing value the most greatly
	It is too many to be with rectification voltmeter check motor end son voltage lower?	Check V/f characteristic value
Motor while operating The rotational speed (rotates / divides) is unstable	Is the load is big ?	Reduce the load
	Is the load change too big?	Reduce the change of load Increase the capacity of the frequency inverter motor
	Use three phases or the single-phase power? Whether lack the looks in the three-phase power?	Whether the wiring which checks the three-phase power lacks the looks.

8、Quality guarantees

The quality assurance of this product is handled in accordance with the following regulations:

8-1、Really belong to the concrete content of quality assurance of maker's responsibility:

8-1-1、While using at home(by calculating from day to produce the goods)

- (a) Produce guaranteeing the repair free of charge , guarantee replacement , caveat vendor in one month after the goods.
- (b) Guarantee the repair free of charge , guarantee replacement in three months after producing the goods.
- (c) Guarantee the repair free of charge in 15 months after producing the goods.

8-2、When the export (does not include domestically abroad), responsible for guaranteeing the repair free of charge buying in six months after producing the goods.

8-3、No matter when, where use our company products of brand, is it serve all the life while being paid to enjoy.

8-4、Our company in all parts of the country is selling, is produced , act for the unit to offer the after-sale service to this product, its service condition is:

8-4-1、Check and serve " tertiaryly " in this unit site(include the trouble clearing).

8-4-2、Is it relate to sell the contract content that the agent signs the responsibility standard of the after-sale service in accordance with our company to need.

8-4-3、Can paid to to is it act for unit ask after-sale service of acting as to

sell each our company (no matter whether guarantee to keep it. in good repair).

8-5、 This product presents the responsibility of quality or the products accident, bear 8-1-1 or 8-2 responsibility of clause only at most, if users need more responsibility compensative suretyship, please insure for property to the insurance company in advance by oneself.

8-6、 In order to produce 15 months from goods date in guarantee period of this product.

8-7、 If belong to the trouble that the following reasons cause, even within guarantee period, belong to and maintain with compensation too:

8-7-1、 Incorrect operation (in accordance with operation instructions for being accurate) is it repair or transform question that cause by oneself to allow

8-7-2、 Go beyond the question that the standard norm demands to use the frequency inverter to cause.

8-7-3、 Drop decreasing or carry the improper damage that cause after buying.

8-7-4、 Because the environment bad device wearing out or troubles caused.

8-7-5、 Because earthquake , fire , geomantic omen calamity , struck by lightning , unusual voltage or other natural calamity or damage that the reason cause together of the calamity

8-7-6、 Because transport the damage in the course. (Note: Transport the way and appoint by the customer, our company helps to go through the formality that the goods transfer)

8-7-7、 When brand , trade mark , serial number , data plate which the manufacturer labels ,etc. damages or unable to recognize.

8-7-8、 Not in accordance with buying and agreeing on paying off funds.

8-7-9、 Or other operating position can objective reality describe to the service unit of our company for install , mix line , operate , maintain.

8-8、 The service for guaranteeing the repair free of charge , guaranteeing replacement , caveat vendor, must return the goods to our company , after confirming responsibility is belonged to , can replace or repair .

8-9、 The machine if because buyer pay off the payment for goods or the left fund close paying on time , the ownership of this machine still belongs to the supply unit, does not also bear above-mentioned responsibility , the buyer can't have objections

Appendix 1:technical regulation

Controlling	control method	Vector control method of the voltage of space	
	Frequency setting of resolution	digit: 0.01 Hz (under100 Hz), 0.1 Hz (above100 Hz) analogue : 0.05 Hz / 50 Hz	
	Frequency precision	Digit: output frequency the most greatly 0.01 % Analogue: output frequency the most greatly 0.1%	
	V/F rate	Linearity, square root, arbitrary V/F	
	Over loading ability	Rating current 150 % -1 minute, Rating current 200% - 0.5second. (The characteristic is in inverse proportion to time)	
	Torque compensation	Hand movement torque compensation (0 - 20 %), automatism torque compensation	
Operating	Entering signal	Working mode	Front panel/ terminal /RS485 message
		Frequency setting	Analogue: 0 - 10V / 4 - 20 mA /, other terminal of sub board (0 - 10V/4 - 20 mA) digit: keyset/RS485 message
		Starting single	positive rotation ,reversal
		Multi-speed	Can set at most 8 speeds (by multifunction terminal)
		Speed-up & speed-down time	0-6000sec, the Speed-up & speed-down time can switch Speed-up & speed-down mode: linearity, S type
		Emergency stop	Interrupt the output of inverter
		Adjusting	Slow-speed operating
		Auto-operating	To operating by setting parameter automatically (7speed)
		Fault resetting	When the protecting function in effective state, it can reset the faulting state automatically .
	Outputting signal	Working state	Frequency checking grade , overloading warning , over voltage , under voltage , overheat of inverter , working , stop , constant rate , program run automatically.
		Output fault	Contact output - AC 250V 1A, DC 30V 1A
		Analogue output	to chose from outputting frequency , outputting electric current , outputting voltage , and DC voltage . (outputting voltage :0 - 10V)
	Operating function	DC brake , frequency restrict , skip the frequency , slip compensation , reversal protecting , PID controlling edc.	

protection	Inverter protection		Overloading voltage, under volt age, overloading electric current, fuse break, grounding faulty , over heating of inverter, overheating of machine , Over loading protection, faulty outside1,2,message error, speed order losing hardware faulty, selecting mistake edc.
	Inverter warning		Stifled and shift defending, overloading warning, temperature sensor faulty
	Instant break the electricity		less than 15 milliseconds: Continuous duty greater than 15 milliseconds: Allow to reset automatically
display	Key board	Workin g single	outputting frequency , outputting electric current, outputting voltage ,setting frequency ,working speed,Dcvoltage.
		Error inform ation	While in faulty protection working state, remain 3 faulty history information.
Circumstance	Ambient temperature		-10 °C ~ 40 °C
	Storage temperature		-20 °C ~ 65 °C
	Ambient humidity		(maximal 90 % RH . (non dew)
	Height/vibrat		less than 1,000 m, 5.9m/seconds
	Apply place		Have no corroded the gas , flammable gas , oil fog or dust and other
Cooling way			Forcible wind cooling

Appendix2:function parameter catalog

Function number	name	Setting range	Least unit	Factory data	Modification	Reference page
00-00	Key board frequency setting	0.00 ~ greatest outputting frequency be the same as function 01-04	Hz	10.00	○	
00-01	outputting frequency		Hz			
00-02	Setting frequency indication		Hz			
00-03	Outputting electric current		A			
00-04	Outputting current rate		%			
00-05	DC bus bar voltage		V			
00-06	Outputting voltage		V			
00-07	Frequency order data indication		Hz			
00-08	Register &data		1			45
00-09	(0.00~99.99) electrify cumulative operation time		hour			
00-10	Cumulative operation time (0.00~99.99)		Hour			
00-11	Cumulative operation time (0000~9999) * 100hours		100 Hours			
00-12	Inputting terminal break on state					28
00-13	outputting terminal break on state					
00-14	outputting frequency p(kW)		0.1KW			
00-15	Outputting torque (remain)		0.1%			
00-16	PI controlling given value		0.1%			
00-17	PI controlling feedback value		0.1%			
00-18	PI digital given value	0.0~100.0%, alike function 05-13	0.1%	100.0	○	
00-19	radiator temperature		0.1℃			
00-20	V2 (I2) inputting value		0.1%			
00-21	VF (IF) inputting value		0.1%			
00-22	option VX inputting value		0.1%			
00-23	V2 (I2) setting data (after transfer)		0.1%			
00-24	VF (IF) setting data (after transfer)		0.1%			

Function number	name	Setting range	Least unit	Factory data	Modification	Reference page
00-25	options VX setting data (after transfer)		0.1%			
00-26	cumulating output kW.h		0.1k			
00-27	cumulating output kW.h		1000k			
00-28	Machine speed indication					
00-29	Machine timing speed of rotation		1rpm			
00-30	Overloading cumulating rate		0.1%			
00-31	inverter rated outputting current		0.1A			
00-32	Inverter rated outputting voltage		V			
00-33	Overloading ability display	0: G type 150%overloading 1: P type 120%overloading				
00-34	Software edition			1.00		
01-00	Working order for chose	0: key board operating 1: Terminal operating 2: RS-485operating	1	0	×	20
01-01	Frequency setting mode 1	0: digital key board 1: terminal V2 (I2) 2: terminal VF (IF) 3: front panel potential device (with potential device type 4: raise and drop terminal 5: RS-485	1	0	×	20
01-02	Frequency setting mode 2	0: Digital key board 1: terminal V2 (I2) 2: terminal VF (IF) 3: front panel potential device (with potential device type 4: raise and drop terminal 5: RS-485	1	0	×	21

Function number	name	Setting range	Least unit	Factory data	Modification	Reference page
01-03	frequency setting for chose	0: Frequency setting 1 1: Frequency setting 2 2: Terminal chose frequency setting1&frequency setting 2 3 : frequency setting 1+ frequency setting 2 4 : frequency setting 1- frequency setting 2 5 : frequency setting 1× frequency setting 2 6 : frequency setting 1/ frequency setting 2 7: min (frequency setting 1, frequency setting 2) 8: max (frequency setting 1, frequency setting 2)	1	0	×	
01-04	front panel frequency setting	0.00~greatest outputting frequency	0.01Hz	10.00 Hz	○	
01-05	Speed - up time 1	0.1s~6000.0s	0.1s	10.0s	○	31
01-06	Speed - down time 1	0.1s~6000.0s	0.1s	10.0s	○	
01-07	upper limit frequency	lower limit frequency~ greatest frequency	0.01Hz	50.00Hz	×	31
01-08	Lower limit frequency	0.00Hz~upper limit frequency	0.01Hz	0.00Hz	×	
01-09	the mini outputting frequency	0.00~greatest frequency	0.01Hz	0.50Hz	×	32
01-10	greatest outputting frequency	10.00~300.0Hz	0.01	50.00 Hz	×	
01-11	Basic frequency setting	10.00~300.0 Hz	0.01	50.00 Hz	×	
01-12	Outputting voltage rate	0.0~110.0%	0.1%	100.0%	×	
01-13	torque compensation	0.0~30.0%	0.1%	2.0%	×	
01-14	Auto torque compensation	0: no 1: yes	1	0	×	26
01-15	V/f mode pattern	0: Line shape 1: Square 2: Self setting V/f mode (remain)	1	0	×	27
01-16	AVR elect	0: Inefficiency 1: efficiency	1	1	×	53

Function number	Name	Setting range	Least unit	Factory data	Modification	Reference page
01-17	Rated input voltage of power supply	0~1100V Set rated voltage of power supply	1V	220V 1* 380V	×	
01-18	DC brake section when starting	0: No 1: Yes	1	0	×	
01-19	DC brake time when starting	0.0~60.0s	0.1s	2.0s	×	34
01-20	DC brake voltage	0.0~30.0%	0.1%	5.0%	×	35
01-21	DC brake frequency when stopping	0.00~300.0Hz	0.01Hz	0.50Hz	×	
01-22	DC brake time when stopping	0.0~60.0s	0.1s	0.0s	×	
01-23	Slip compensation gain	0~150% (invalid when 0)	1%	0	×	35
01-24	Motor overload protection model	0: No 1: Standard motor 2: conversion motor	1	1	×	55
01-25	Motor overload protection level	0~110	1%	100%	×	
01-26	Carrier frequency	1~9 KHz	1 kHz	Factory value according to power	○	33
01-27	Current limitation selection	0: Invalid 1: Vvalid	1	0	×	53
01-28	Current limiting value	20.0~180.0%	0.1%	G model 150.0 P model 120.0	×	
01-29	Over voltage stalling prevent selection	0: Invalid 1: Valid	1	1	×	52
01-30	Auto energy-saving run selection	0: Invalid 1: Valid	1	0	×	58
01-31	Acceleration time 2	0.1s~6000.0s	0.1s	15.0s	○	31
01-32	Deceleration time 2	0.1s~6000.0s	0.1s	15.0s	○	
01-33	Acceleration time 3	0.1s~6000.0s	0.1s	20.0s	○	
01-34	Deceleration time 3	0.1s~6000.0s	0.1s	20.0s	○	
01-35	Acceleration time 4	0.1s~6000.0s	0.1s	30.0s	○	
01-36	Deceleration time 4	0.1s~6000.0s	0.1s	30.0s	○	
01-37	Acceleration and deceleration S curve	0: linearity 1: S curve (begin) 2: S curve (end) 3: S curve (all)	1	0	×	32

Function number	Name	Setting range	Least unit	Factory data	Modification	Reference page
01-39	First stage speed	Lower limiting frequency ~ upper limiting frequency	0.01Hz	10.00Hz	○	46
01-40	Second stage speed	Lower limiting frequency ~ upper limiting frequency	0.01Hz	20.00Hz	○	
01-41	Third stage speed	Lower limiting frequency ~ upper limiting frequency	0.01Hz	30.00Hz	○	
01-42	Fourth stage speed	Lower limiting frequency ~ upper limiting frequency	0.01Hz	40.00Hz	○	
01-43	Fifth stage speed	Lower limiting frequency ~ upper limiting frequency	0.01Hz	50.00Hz	○	
01-44	Sixth stage speed	Lower limiting frequency ~ upper limiting frequency	0.01Hz	6.00Hz	○	
01-45	Seventh stage speed	Lower limiting frequency ~ upper limiting frequency	0.01Hz	7.00Hz	○	
01-46	Skipping frequency 1	0.00~300.0Hz	0.01Hz	0.00Hz	○	57
01-47	Skipping frequency 2	0.00~300.0Hz	0.01Hz	0.00Hz	○	
01-48	Skipping frequency 3	0.00~300.0Hz	0.01Hz	0.00Hz	○	
01-49	Skipping frequency range	0.00~50.00Hz	0.01Hz	2.00Hz	○	
01-50	Adjusting frequency	0.00~50.00Hz	0.01Hz	5.00Hz	○	42
01-51	Lower frequency selection	0: Run 1: Stop	1	0	0	98
02-00	Motor rated voltage	0~1100V Setted motor rated voltage	1V	220V 1* 380V	×	
02-01	Motor rated voltage	0.0~900.0A Setted motor rated current	0.1A	Inverte rrated curren t	×	
02-02	Motor rated frequency	10.00~300.0 Hz Setted motor rated frequency	0.01 Hz	50.00 Hz	×	
02-03	Motor rated rotational speed	0~9000RPM Setted motor rated rotational speed	1RPM	1425	×	
02-04	Motor phase num.	2~12 Setted motor phase Num	2	4	×	
02-05	(Remain)					
02-06	Motor None-load current	0~100%	1%	50%	○	
02-07	Auto reset num when malfunction	0~10	1	0	×	56
02-08	Delay time of auto reset	0.0~60.0s	0.1s	5.0 s	×	
02-09	Recovery time of resetting times	0.0~6000s	0.1s	600.0 s	×	

Function number	Name	Setting range	Least unit	Factory data	Modification	Reference page
02-10	Malfunction relay action when reseted from malfunctiona	0: Recovery from malefaction relay non-action 1: Recovery from malfunction relay action	1	0	×	
02-11	Instant power off restarting selection	0: No start 1: Resetand run after voltage recovery	1	0	×	57
02-12	Allowed max.cut-off time	0.0~60.0s	0.1s	10.0s	×	
02-13	Trace start ways	0: Tracing start after malfunction 1: Tracing start all time 2: Invalid tracing start	1	0	×	57
02-14	Speed trace against deceleration time	0.1~20.0s	0.1s	2.0s	×	
02-15	Speed trace against voltageproportion	10~100%	1%	100%	×	
02-16	Stop way	0: Deceleration stop 1: Free stop	1	0	×	34
02-17	Control ways of terminal running	0: Two lines control mode 1 1: Two lines control mode 2 2: Three lines control mode 1 3: Three lines control mode 2	1	0	×	40
02-18	Front panel stop key selection	0: Invalid when on terminal running way 1: Stop key valid when on terminal running way	1	0	×	
02-19	Electric deal way on terminal running	0: Deal upper valid terminal instruction 1: Deal no upper valid terminal instruction	1	0	×	41
02-20	Reset and restart ways selection	0: Deal reset valid terminal instruction 1: Not deal reset valid terminal instruction	1	0	×	41
02-21	Inversion prohibited	0: Allow inversion running 1: not allow inversion running	1	0	×	33

Function number	Name	Setting range	Least unit	Factory data	Modification	Reference page
03-00	Multi-function input terminal D1	D1 Terminal designed as: 0: Invalid 1: Multi-stage speed terminal first. 2: Multi-stage speed terminal second. 3: Multi-stage speed terminal third. 4: Rising frequency instruction 5: Falling frequency instruction 6: Malfunction reset instruction 7: EF, out unnormal, NO contact point input N.O 8: EF, out unnormal, , NCcontact point input N.C 9: Sencon add-and-subtract speed time selection 10: Free stop instruction 11: Adjusting selection 12: Three line run maintenance 13: Counter import terminal 14: Clear counter 15: Timer input 16: Program runing pause 17: Prohibit add-subtract instruction 18: REF1/REF2 frequency switching 19: Front panel operation instruction 20: PI control cancel other: remain	1	Multi stage speed 1	○	44
03-01	Multi-function input terminal D2	D2 Terminal set same as 03-00	2	Multi stage speed2	○	44
03-02	Multi-function input terminal D3	D3 Terminal set same as 03-00	3	Multi stage speed 3	○	

Function number	Name	Setting range	Least unit	Factory data	Modification	Reference page
03-03	Multi-function input terminal D4	D4 Terminal set same as 03-00	9	Add-subtract 2	○	
03-04	Multi-function input terminal D5	D5 Terminal set same as 03-00	10	FREE	○	
03-05	Multi-function input terminal D6	D6 Terminal set same as 03-00	6	RESET	○	
03-06	Open collector output selection 1	(Open collector output 1) 0~30 0: No output 1: Running (have run instruction) 2: Malfunction instruction 3: Zero-speed (Motor rotating speed is Zero) 4: Running frequency reach setted frequency 5: Reach frequency level measuring value 6: Greater than frequency level measuring value 7: Less than frequency level measuring value 8: Running frequency equal low limiting frequency 9: Running frequency equal upper frequency 10: Inversion running 11: Counter reach setted value 12: Counter reach Max. value 13: Timer output 14: VF (IF) Singal lost 15: Motor overload warning 16: electric thermal overload pre-warnig (Overload accumulating percent greater than 50%) 17: Malfunction auto-reset 18: Under-voltage 19: Out malfunction 20: Inverter running prepared 21: V2 (I2) Signal lost 22: PLC stage running completed 23: PLC Circle cycle completed Other: reserve	1	15	○	36

Function code	Name	Setting range	Min unit	Factory value	Modification	Reference page
03-07	Open collector output 2	Open collector output 2 (SP2), 0~30 same as 03-06	1	18	○	36
03-08	Relay 1 output selection	Output relay1 (TA1, TC1) 0~30, same as 03-06	1	1	○	
03-09	Relay2 output selection	Output relay 2(TA2, TB2, TC2) 0~30, same as 03-06	1	2	○	
03-10	Frequency level measuring value	0.00~300.0Hz	0.01Hz	30.00Hz	○	38
03-11	Frequency measuring range	0.00~10.00Hz	0.01Hz	1.00Hz	○	
03-12	Overload warning current level	0.0~150.0%	0.1%	100.0%	○	
03-13	Counter setting value	1~Counter Max.	1	50	○	45
03-14	Counter Max.	1 ~ 9000 , Counter reach Max., then back to 1	1	100	○	
03-15	Timing time when close	0.0~6000.0s	0.1s	2.0s	○	43
03-16	Timing time when break	0.0~6000.0s	0.1s	2.0s	○	
03-17	V2 (I2) Input signal gain	-500.0~500.0%	0.1%	100.0%	○	39
03-18	V2 (I2) Input signal bias	-500.0~500.0%	0.1%	0.0%	○	
03-19	V2 (I2) Input signal type	0: 0~10V (0~20mA) 1: 2~10V (4~20mA) 2: 2~10V (4~20mA) With signal lost protection 3: -10V~10V (preserve)	1	0	○	
03-20	V2 (I2) Output filtering time constant	0.00~10.00s	0.01s	0.50 s	○	
03-21	VF (IF) Input signal gain	-500.0~500.0%	0.1%	100.0%	○	51-52
03-22	VF (IF) Input signal bias	-500.0~500.0%	0.1%	0.0%	○	
03-23	VF (IF) Input signal type	0: 0~10V (0~20mA) 1: 2~10V (4~20mA) 2: 2~10V (4~20mA) With signal lost protection 3: -10V~10V (preserve)	1	0	○	
03-24	VF (IF) Input filtering time constant	0.00~10.00s	0.01s	0.50 s	○	
03-25	Option VX Output signal gain	-500.0~500.0%	0.1%	100.0%	○	
03-26	Option VX Input signal bias	-500.0~500.0%	0.1%	0.0%	○	
03-27	Option VX Input signal type Note: With potentiometer model corresponding parameter	0: 0~10V (0~20mA) 1: 2~10V (4~20mA) 2: 2~10V (4~20mA) With signal lost protection 3: -10V~10V	1	0	○	

Function code	Name	Setting range	Min unit	Factory value	Modification	Reference page
03-28	Option VX Input filtering time constant	0.00~10.00s	0.01s	0.50 s	○	
03-29	Negative frequency set as inversion	0: Negative is Zero frequency! 1: Input signal correspond to straight line frequency, negative frequency is inversion	1	0	×	40
03-30	Simulation meter output selection	0: No simulation meter output 1: Frequency output (Max. frequency correspond to 10V) 2: Output current (200% correspond to 10V) 3: DC main line voltage (1000V correspond to 10V) 4: Output voltage (Motor rated voltage correspond to 10V)	1	1	○	35
03-31	Simulation meter gain regulation	Use to correct simulation meter -200.0~200.0%	0.1%	100.0%	○	36
03-32	Simulation meter bias regulation	Use to correct simulation meter -200.0~200.0%	0.1%	0.0%	○	36
03-33	Simulation meter output filtering time constant	0.00~10.00s	0.01s	1.00 s	○	

Function code	Name	Setting range	Min unit	Factory value	Modification	Reference page
04-00	Program running ways	0: Program running invalid 1 : Program running circulating running 2 : Program running stop after a week 3: Program running after a cycle, running on last stage	1	0	×	47
04-01	Program running stage digit display		1			
04-02	Program running stage time display		0.1s			
04-03	Program running stage residual time display		0.1s			
04-04	First stage time	0~6000.0 s	0.1s	20.0s	○	
04-05	Second stage time	0~6000.0 s	0.1s	20.0s	○	
04-06	Third stage time	0~6000.0 s	0.1s	20.0s	○	
04-07	Fourth stage time	0~6000.0 s	0.1s	20.0s	○	
04-08	Fifth stage time	0~6000.0 s	0.1s	20.0s	○	
04-09	Sixth stage time	0~6000.0 s	0.1s	20.0s	○	
04-10	Seventh stage time	0~6000.0 s	0.1s	20.0s	○	
04-11	One stage running add-subtract speed time selection	1~4	1	1	○	48
04-12	Two stage running add-subtract speed time selection	1~4	1	1	○	
04-13	Three stage running add-subtract speed time selection	1~4	1	1	○	
04-14	Four stage running add-subtract time selection	1~4	1	1	○	
04-15	Five stage running add-subtract time selection	1~4	1	1	○	
04-16	Six stage running add-subtract speed time selection	1~4	1	1	○	
04-17	Seven stage running add-subtract speed time selection	1~4	1	1	○	

Function code	Name	Setting range	Min unit	Factory value	Modification	Reference page
04-18	Wobble running ways	0: Wobble running invalid 1: Wobble running valid	1	0	×	51
04-19	Wobble running amplitude value FH	0.10-50.00Hz	0.01Hz	5.00 Hz	×	
04-20	Wobble running difference frequency Δf	0.00-5.00Hz	0.01Hz	1.00 Hz	×	
04-21	Wobble running rising time T1	0.1-6000s	0.1s	20.0 s	○	
04-22	Wobble running falling time T2	0.1-6000s	0.1s	20.0 s	○	
05-00	PI Controlling ways	0: Invalid 1: PI closed loop control	1	0	×	48
05-01	PI Regulate error polarity	0: anode 1: cathode	1	0	×	
05-02	PI Given signal selection	0: Digit given 1: Out V2 (I2) 2: Out VF (IF) 3: Option VX Input 4: RS485	1	0	×	
05-03	PI Digit	0.0~100.0%	0.1%	100.0%	○	
05-04	PI Feedback signal select	0: (remain) 1: OutsideV2 (I2) 2: OutsideVF (IF) 3: optionsVX input 4: RS485	1	2	×	
05-05	(remain)					48
05-06	The proportion gaining P	0.0~100.0	0.1	1.0	○	
05-07	Integral time	0.0~100.0s	0.1s	10.0s	○	
05-08	Defferential Time	0.000~2.000s	0.001s	0.000s	○	
05-09	PI adjust the min running frequency	0.0~upper limit frequency	0.01Hz	0.00Hz	○	
05-10	PI adjust the max running frequency	0.0~upper limit frequency	0.01Hz	50.00Hz	○	

Function code	Name	Setting range	Min unit	Factory value	Modification	Reference page
06-00	Over torque protection ways	0: Over the torque and does not measure 1: Over the torque measureduring during constant speed running, after torque measureduring it will warning 2: Over the torque measureduring during constant speed running, after torque measureduring it will warning 3: Over the torque measureduring during constant speed running, it is fault 4: Over the torque measureduring during constant speed running, it is fault	1	0	○	54
06-01	Cross the torque protection current	50.0~150.0%	0.1%	150.0%	○	
06-02	Over the torque protectiontime	0.0~100.0s	0.1s	1.0s	○	
06-03	Cooling fan action selection	0: Not control, full control 1: According running instruction to control running 2: Automatically control running according to radiator	1	1	○	
06-04	Motor lack phase protection selection	0: No protection 1: Lack phase protection	1	0	○	
06-05	DC voltage waving protection selection	0: Not protection 1: Protection	1	0	○	
06-06	Energy saving brake selection	0: No 1: Safty model 2: Generally type	1	0	×	53
06-07	Low load pre-warning current level	0.0~100.0% (Invalid when 0)	0.1%	0.0%	○	
06-08	Low load pre-load protection time	0.0~100.0s	0.1s	1.0s	○	

Function code	Name	Setting range	Min unit	Factory value	Modification	Reference page
06-09	V2 (I2) Input over-high measuring level	0.0~100.0% (0)	0.1%	0.0%	○	
06-10	V2(I2)Measuring protection time	0.0~10.0s	0.1s	1.0s	○	
07-00	Present trouble information					
07-01	The last trouble information					
07-02	Trouble information two times recently					
07-03	Trouble information three times recently					
07-04	Remove the historical record of the trouble	0: Invalid 1: Clear	1	0		
07-05	Clear accumulative running data	0: Invalid 1: Clear accumulating running time 2: Clear accumulating kW*h table	1	0		
07-06	Output frequency at the time of the last trouble		Hz			
07-07	Establish frequency at the time of the last trouble		Hz			
07-08	Export the electric current at the time of the last trouble		A			
07-09	Voltage of bus bar of direct current at the time of the last trouble		V			
07-10	Output the voltage at the time of the last trouble		V			

Function code	Name	Setting range	Min unit	Factory value	Modification	Reference page
08-00	RS-485 Mailing address	1~31	1	1	×	59
08-01	Communication Potter rate	0: 1200 1: 2400 2: 4800 3: 9600 4: 19200 5: 38400	1	2	×	
08-02	Detection time for transmission interrupt	0.1~60.0s	0.1s	0.0s	×	
08-03	Transmit the mistake to deal with	0: Alarm 1: Stop	1	0	×	
10-00	Initialize the parameter	22: Resume factory value Other: Invalid	1	0	×	27
10-01	The parameter locking	0: Can revise 1: The parameter locking	1	0	○	27
10-02	Have the electricity and monitor the function to choose initially	0: Output frequency H 1: Establish frequency F 2: Export electric current A 3: Establish and show c 4 by oneself: Establish and show 'y' by oneself	1	0	○	27
10-03	0 establishes and shows the function by oneself 'c'	Function code 0000~0999	1	0005	○	27
10-04	Establish and show function 'y' by oneself	Function code 0000~0999	1	0009	○	28
10-05	Mechanical speed coefficient	0~9999	1	100.0	○	27
10-06	Coefficient decimal place of the mechanical speed	0~3	1	1	○	

1*: Dispatched from the factory the establishing value and divided into 200V grade and 400V grade . 2: ○Show the parameter that the frequency inverter can be revised while operating
3: ×Show the parameter that the frequency inverter can't be revised while operating, revise under stopping the state.

Appendix 3: External dimension

45KW and below type (without vector control) externality:

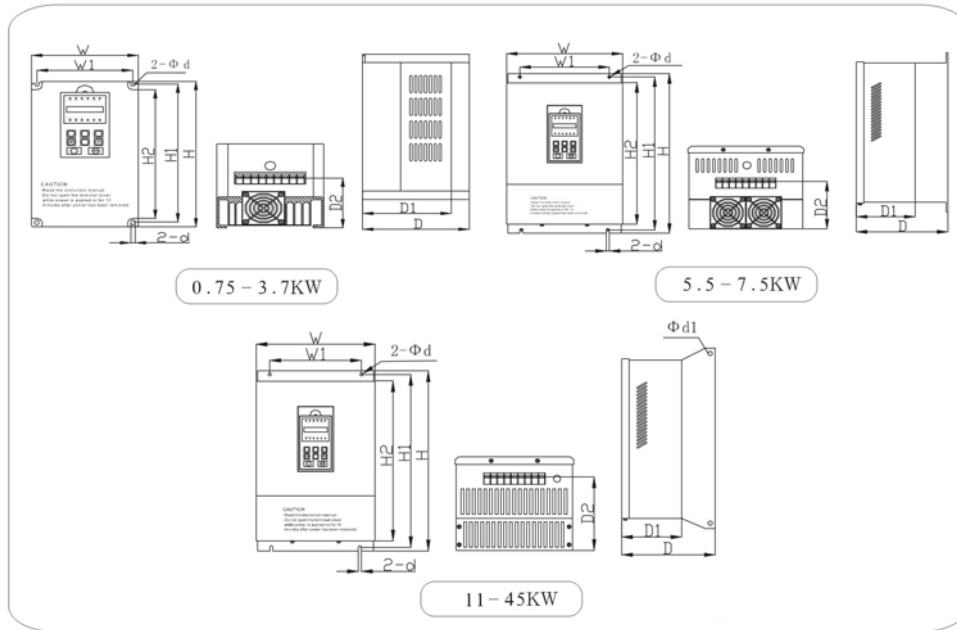

45KW and below type (without vector control) externality:

45KW and below type (without vector control) size:

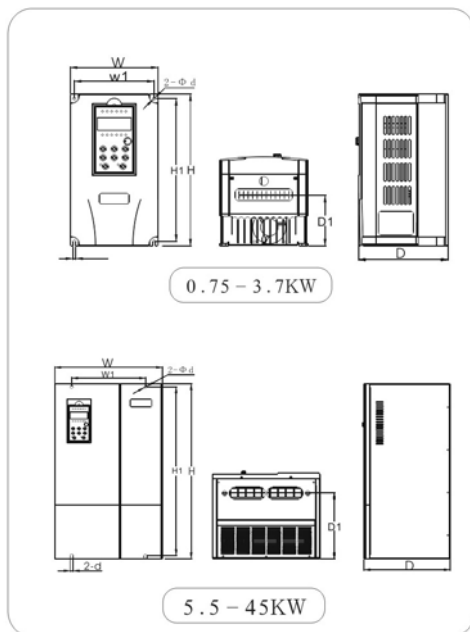

Specification	W	W1	H	H1	H2	D	D1	D3	d	d1
G1R5T4	150	135	260	245	230	150	121	80	5.5	
G2R2T4										
G3R7T4										
G5R5T4	214	140	320	305	299	150	97	80	7	
G7R5T4										
G011T4	260	200	394	378	352	205	133	164	7	10
G015T4										
G018T4										
G022T4	295	200	495	475	460	253	165	215	10	10
G030T4										
G037T4	350	240	594	570	550	280	184	215	10	10
G045T4										

45KW and below type (with vector control) size:

Specification	W	W1	H	H1	H2	D	D1
G1R5T4	150	135	260	245	150	90	6
G2R2T4							
G3R7T4							
G5R5T4	214	140	320	306	165	97	7
G7R5T4							
G011T4	230	150	360	344	200	114	7
G015T4							
G018T4	260	200	381	364	215	175	7
G022T4	290	200	500	480	255	205	10
G030T4							
G037T4	350	240	570	550	280	215	10
G045T4							

55KW and above type size:

规格	W	W1	H	H1	H2	D	D1	d	d1
G055	430	300	674	654	631	305	228	12	12
G075									
G093	530	210	915	885		315		12	
G110									
G132									
G160	600	180	1270	1230		408		12	
G185									
G200	620 (W) * 1250 (H) * 423 (D)								
G220									
G250	700 (W) * 1400 (H) * 423 (D)								
G280									
G315	780 (W) * 1500 (H) * 453 (D)								
G400									
G450	1000 (W) * 1800 (H) * 600 (D)								
G500									
G630									

55KW and above type externality:

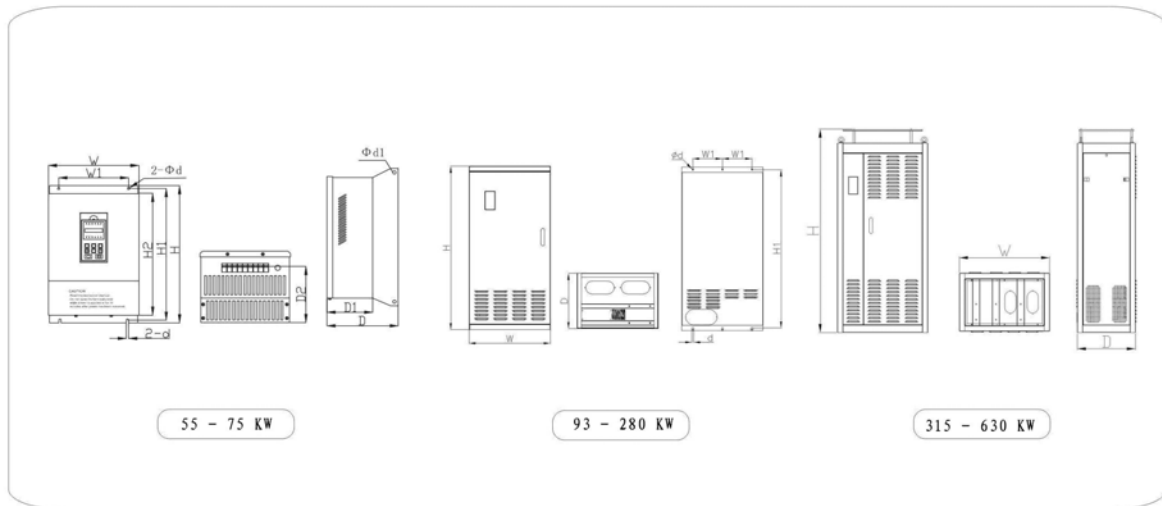

Note:

1. Above machine externality and size take the type of G for example. The type of P and ZS is about equal to the sample. For more accurate understanding of it, please consultation agent or manufacturer.

2. Our company maybe change the externality and siz in the process of product improve, above chart maybe is different with actual, please consultation agent or manufacturer.

Appendix4: Every type rated output ampere meter

Tyep	Rated voltage	Rated voltage	Rated output current	Adapter motor
CS3200-G1R5T4	380-415v	1.5kW	3.7A	1.5kW
CS3200-G2R2T4	380-415v	2.2kW	5A	2.2kW
CS3200-G3R7T4	380-415v	3.7kW	8A	3.7kW
CS3200-G5R5T4	380-415v	5.5kW	13A	5.5kW
CS3200-G7R5T4	380-415v	7.5kW	16A	7.5kW
CS3200-G011T4	380-415v	11kW	25A	11kW
CS3200-G015T4	380-415v	15kW	32A	15kW
CS3200-G018T4	380-415v	18.5kW	38A	18.5kW
CS3200-G022T4	380-415v	22kW	45A	22kW
CS3200-G030T4	380-415v	30kW	60A	30kW
CS3200-G037T4	380-415v	37kW	75A	37kW
CS3200-G045T4	380-415v	45kW	90A	45kW
CS3200-G055T4	380-415v	55kW	110A	55kW
CS3200-G075T4	380-415v	75kW	150A	75kW
CS3200-G090T4	380-415v	90kW	170A	90kW
CS3200-G110T4	380-415v	110kW	210A	110kW
CS3200-G132T4	380-415v	132kW	250A	132kW
CS3200-G160T4	380-415v	160kW	300A	160kW
CS3200-G185T4	380-415v	185kW	340A	185kW
CS3200-G200T4	380-415v	200kW	380A	200kW
CS3200-G220T4	380-415v	220kW	415A	220kW
CS3200-G250T4	380-415v	250kW	470A	250kW
CS3200-G280T4	380-415v	280kW	540A	280kW
CS3200-G315T4	380-415v	315kW	600A	315kW
CS3200-G375T4	380-415v	375kW	710A	375kW
CS3200-G400T4	380-415v	400kW	750A	400kW
CS3200-G450T4	380-415v	450kW	850A	450kW
CS3200-G500T4	380-415v	500kW	930A	500kW
CS3200-G630T4	380-415v	630kW	1170A	630kW

Tyep	Rated voltage	Rated voltage	Rated output current	Adapter motor
CS3200-G1R5T2	200-230v	1.5kW	7A	1.5kW
CS3200-G2R2T2	200-230v	2.2kW	10A	2.2kW
CS3200-G3R7T2	200-230v	3.7kW	16A	3.7kW
CS3200-G5R5T2	200-230v	5.5kW	20A	5.5kW
CS3200-G7R5T2	200-230v	7.5kW	30A	7.5kW
CS3200-G011T2	200-230v	11kW	42A	11kW
CS3200-G015T2	200-230v	15kW	55A	15kW
CS3200-G018T2	200-230v	18.5kW	70A	18.5kW

CS3200-G022T2	200-230v	22kW	80A	22kW
CS3200-G030T2	200-230v	30kW	110A	30kW
CS3200-G037T2	200-230v	37kW	130A	37kW
CS3200-G045T2	200-230v	45kW	160A	45kW

Tyep	Rated voltage	Rated voltage	Rated output current	Adapter motor
CS3200-G022T6	660-690v	22kW	28A	22kW
CS3200-G030T6	660-690v	30kW	35A	30kW
CS3200-G037T6	660-690v	37kW	45A	37kW
CS3200-G045T6	660-690v	45kW	52A	45kW
CS3200-G055T6	660-690v	55kW	63A	55kW
CS3200-G075T6	660-690v	75kW	86A	75kW
CS3200-G090T6	660-690v	90kW	98A	90kW
CS3200-G110T6	660-690v	110kW	121A	110kW
CS3200-G132T6	660-690v	132kW	150A	132kW
CS3200-G160T6	660-690v	160kW	175A	160kW
CS3200-G185T6	660-690v	185kW	198A	185kW
CS3200-G200T6	660-690v	200kW	218A	200kW
CS3200-G220T6	660-690v	220kW	240A	220kW
CS3200-G250T6	660-690v	250kW	270A	250kW
CS3200-G300T6	660-690v	300kW	340A	280-315kW
CS3200-G350T6	660-690v	350kW	390A	350kW
CS3200-G400T6	660-690v	400kW	430A	375-430kW
CS3200-G500T6	660-690v	500kW	540A	500kW
CS3200-G600T6	660-690v	600kW	600A	600kW

Appendis5: Safeguard and check regularly

Check the place	Inspect Item	Inspect	Cycle			Control method	Standard	Measuring instrument
			Everyday	1 Year	2 Year			
All	Surroundings environment	Is there dust? Do the environment temperature and the degree of humidity accommodations ?	√			Consult the regulation	:-10 ~ +40 °C s, have no dust. Degree of humidity:90% did not form dew the as follows	Thermometer Hygrometer Record the instrument
	Equipment	Is there is noise or shake?	√			See, hear	Have no abnormality	
	Input voltage	Is main circuit of input voltage normal?	√			Measuring terminal R, S, T of the voltage		Digit multi-meter/ Measuring instrument
All		High resistance meter(Between main circuit and ground) Are there regular movable parts? If each part has overheated sign? Clear		√		Unclamp the frequency inverter, short terminal of R,S,T, U,V,W, and measure between the terminaland ground Fasten the screw The naked eye checking	Exceed 5 MΩ No fault	Direct 500V type high resistance meter
	Conductor or Wire	Does the conductor get rusty? Does the line crust damaged?		√		The naked eye checking	No fault	
	Terminal	Damage ?		√		The naked eye checking	No fault	
	IGBT mould /Diode	Check the impedance among the terminal			√	Unclamp the connection of the frequency inverter and use the measurement of the tester, and resistance between R, S, T<-> +, - 和 U, V, W <-> +, -。		Digit multi-meter/ Simulation measuring apparatus

	train waves Condenser	Whether there is liquid that is oozed out Whether the safe hole is outstanding? Whether have found the inflation of the electric capacity	√	√		The naked eye is checked. Measure by the capacitor measurement equipment	No fault Exceed rated capacity 85%	Capacitor measurement equipment
	Relay	If there is noise and shake while operating? Whether the contact is damaged		√		Hear and check The naked eye checking.	No fault	
	Resistance	Whether the insulation of the resistance is damaged Whether wire is damaged between resistance (open circuit)		√		The naked eye checking.. Disconnect one and measure by instrument	No fault The error must Less than 10% of resistance value displayed	Digitmultimeter/Simulation measuring apparatus
Control circuit Protection circuit	Running check	Whether every phase of output voltage uneven? There is no mistake in circuit after carry out order protection		√		Measure ourput terminal between U, V, W Short and open inverter output circuit	For 200V (400V) , Voltage of every phase can not exceed4V (8V)	Digitmultimeter/Correction voltermeter
Cooling system	Cooling fan	If there is unormal noise or shake? Whether the junction becomes flexible	√	√		Rotate the fan with hands after shutting off the power Fasten the connection	Must rotate steadily, No fault	
display	meter	Display right or not?	√	√		Check the reading of the measuring apparatus in the panel outside	Check the establishi ng value	Voltmeter /watt hour meter and so on
Motor	All	If there is unnormal noise or shake? Whether there is unusual smell?	√			Checked by the sense of hearing , sense of smell , naked eye, check overheat or damage	No fault	
	Insulation resistance	High resistance meter check (between output terminal and ground)			√	Loose U, V, W connect and fasten the motor wire	Exceed 5 MΩ	500V type high resistance meter

Note: Value in the bracket is suitable for 400V type frequency inverter

Appendix 6 CS3200' S RS-485 Communication agreement

- 1、RS-485 The definition of series communication terminal as follows:
 SG+: Signal positive end
 SG-: Signal negative end
 Before using RS-485 series communication interface, use front panel set inverter "RS-485 Potter rate" and "Communication add".
- 2、Adopt asynchronous to transmit, one host computer send, many set very receive from plane (frequency inverter), have not received the host computer to ask , can't send information from the machine voluntarily.
- 3、Potter rate:

4、Digit format

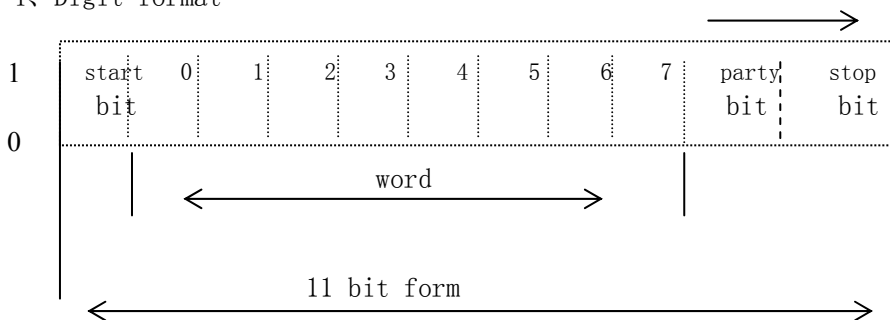

Note: With location check-up, use as realizing a lot of machine communication, while sending the frequency inverter address (the byte of A), party bit =1, other byte party bit =0

5、Error-correcting method:

Adding checksum after information, checksum is equal to the last byte in the sum of all bytes.

6、Data packet form :AKP D₃D₂D₁D₀S

A、 K、 P、 D₃D₂ D₁D₀、 S is separately one bit hexadecimal number.

A: Sub machine (frequency inverter) addressThe address range of the frequency inverter is (1-31) , A must exist.

Notice: Address A =Come into force to all from plane at the 00H, and no all loopback information from the machine, so A=00H just running by order.

K:。 Data packet fuction

P: Parameter code, para mark, two byte hexadecimal number.

D₃D₂D₁D₀: Remove the parameter value of the decimal point, 16 systems of the four bytes are counted altogether, send the high bit firstly, and then send the bottom bit . (see " establishing value range " of every parameter of " parameter table " in the decimal point position.)

S: Check the word with school. S is sum of bit in hexadecimal number (A+K+P+ D3+D2+D1+D0) get last bit 7—bit0) Value.

The definition of K、P、D3D2D1D0 as follows:

K	P	D3D2D1D0
K=0: preserve		
K=1: preserve		
K=2: send running instruction	P: 1=STOP/RESET, 2=FW D, 3=REV	No means
K=3: Check running state	Host machine sent P: No means Sub-machine reply P: 1=STOP, 2=FWD, 3=REV, 4=BRK	No means
K=4: Set running parameter	P: 1=Given frequency while running (two bit valid decimal)	Remove decimal point of setted value
	P: 7=Given PI when running (one bite valid decimal)	Remove decimal point of setted value
K=6: set function parameter	P: Parameter mark	Remove the actual settlement value of the decimal point
K=7: Check function parameter	P: Parameter mark	The host computer sends : Pointless Sub computer reply: Remove the present actual value of the decimal point
K=8: Preserve		
K	P	D3D2D1D0
K=FOH: The host computer received orders when the sub computer is unable to carry out, sub computer reply K=FOH	Pointless	Pointless
K=FCH: Host computer sent invalid parametr, sub-computer reply K=FCH		
K=FDH: Host computer sent parameter exceed limit, sub-computer reply , K=FDH		
K=FEH: Setted parameter of host computer was locked, sub computer reply K=FEH		
K=FFH: Sub-computer reply and check the mistake		

*Note 1: If regarded as correct available value from host computer when the host computer sends all establishment data bags , reply the data received.

*Note 2: From K =FOH reaches K =FFH is it inform one-way message of host computer to go back from host computer (frequency inverter), the host computer does not send this kind of information , if when the host computer picks up and finds the mistake of byte of check-up , can send again an original information , and does not send K =FFH information.

*Note 4: The information value of the trouble is expressed as follows:

	00: There is no trouble
Lu	25: The main return circuit is insufficient in voltage (PUV)
oc	01: Over current (OC)
ou	04: Over voltage (OV)
Grd	19: Ground fault (Grd)
oh	03: Over heat of radiator (oh)
oht	28: Over heat of raditor (oht)
oL	07: Over load of motor (oL)
oL2	26 : Over load of frequency convertor (oL2)
oL3	29: Over torque check (oL3)
ocP	02: Load short circuit (oCP)
EF	08: External fault (EF)
SPi	30: The direct current of bus bar is fluctuated too big (SPi)
SPo	23: Output lack phase (SPo)
LL	12: Under voltage protection (LL)
EEP	22: EEPROM fault (EEP)
ErP	11: Parameter setting fault (ErP)
cE	31: RS-485 Communication trouble (cE)
Lo2	14: V2(I2) Signal lost Lo2
LoF	15: VF(IF) Signal lost LoF
Lo3	16: Options VX signal lost(Lo3)
Er5	20: Inner circuit trouble(Er5)
Er6	24: Motor rated current setted is too big(Er6)
oPr	32 : Front panel communication trouble (oPr1)

7、Interval between A(bit) and K(bit) <20ms, and interval among other bit<10ms, The time of dealing after recived a data bag is less than 80ms.

Example 1、Set running parameter

11# Inverter change it' s “setting frequency” as 35.00Hz when it is on running state. 为 35.00Hz。

Step as :

35.00 remove decimal point as 3500D=0DACH
A=11=0BH (Inverter add as "0BH")
K=04H (Running parameter set as "04H")
P=0001H (Running frequency set as "0001H")
D₃=00H (Data high bit as "00H")
D₂=00H (Data second bit as "00H")
D₁=0DH (Data second low bit as "0DH")
D₀=ACH (Data low bit as "ACH")
S=C9H (Check bit as "C9H")
(S=0BH+04H+00H+01H+00H+00H+0DH+ACH =C9H)
Host computer sent bit as fellow data bags by order : 0BH, 04H, 00H, 01H, 00H, 00H, 0DH, ACH, C9

Example 2、Function parameter set

Set 18# the value of machine board "P0105 accelerate time" as 990.0 sec. parameter mark0105D=0069H

Step as 下: 990.0 remove decimal point as 9900D=26ACH
A=18=12H (Inverter add as "12H")
K=06H (Function parameter as "06H")
P=0069H (Parameter mark digit No. as "0069H")
D₃=00H (Data high bit as "00H")
D₂=00H (Data second high bit as "00H")
D₁=26H (Data second low bit as "26H")
D₀=ACH (Data low bit as "ACH")
S=53H (Check bit as "53H")
(S=12H+06H+00H+69H+00H+00H+26H+ACH=1 **53**H)
Host computer sent bit as fellow data bags by order: 12H, 06H, 00H, 69H, 00H, 00H, 26H, ACH, 53H

If frequency inverter correct to is it get data the above make to receive, frequency inverter reply the copy:

12H, 06H, 00H, 69H, 00H, 00H, 26H, ACH, 53H.

Appendix7:Auxiliary instruction of CS3200 series inverter used in modification of injection machine

Main circuit wiring terminal graph

Simple modification in wiring terminal graph only used in inverter

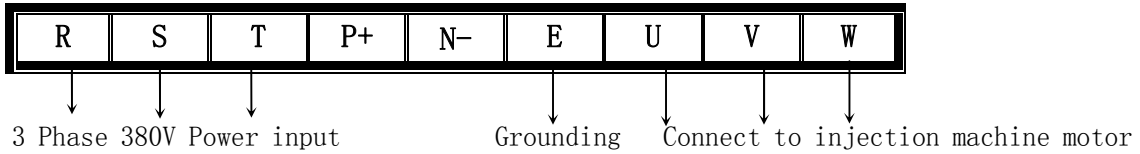

Wiring graph of saving power device of intelligent cabinet type injection machine

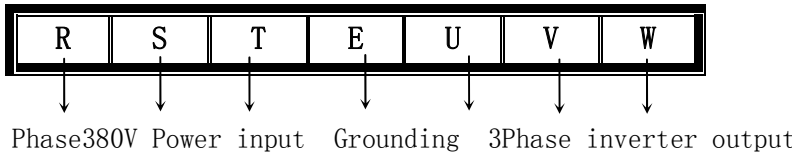

saving power device of intelligent cabinet type injection machine is a kind of distribution cabinet which can convert from city electricity to frequency change and power saving or in contrary way, installation and maintenance is convenient, in case of fault of inverter which can change into power frequency working way and minimum the lost because the fault of inverter.

Wiring way of main circuit of modification of injection machine

For direct start and stop injection machine the oil pump motor

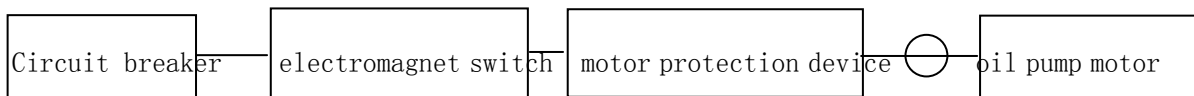

When transforming, fetch the power wire from hot protector of motor to the power input end of frequency convertor(or intelligence power saving control cabinet), and connect the wire of oil motor to output end of frequency convertor(or intelligence power saving control cabinet)..

For injection machine with reduced voltage starting oil pump motor, circuit as follows

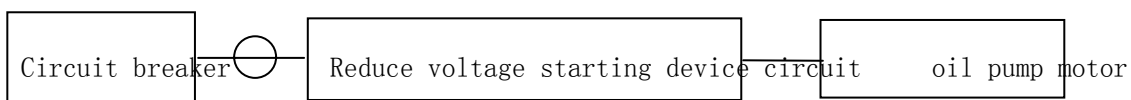

When transforming, fetch the power wire of front-end of reduce voltage starting device or after-end of circuit breaker to power input end of frequency convertor(or

intelligence power saving control cabinet), connect the output-end of frequency inverter(or intelligence power saving control cabinet) to main circuit input end of reduce voltage starting.

Change board wiring way note:

Change board located in right side of CPU, as

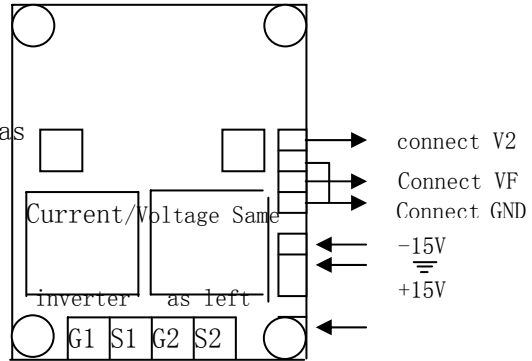

- G1**---connect proportional signal negative-terminal
- S1**---- connect proportional signal positive-terminal
- G2**---Connect proportional signal negative-terminal
- S2**---Connect propproportional signal positive terminal

Generally speaking, only need to connect the signal of flow of proportion and finish generally frequency conversion reducing energy consumption of the injection machine, meet the technological requirement of its product, should connect No. two signal under the situation expected much.

User can connect the G1, S1 to control circuit of proportion flow valve seriesly and connect the G2, S2 to control circuit of proportion pressure valve according to the way of current circuit. For reducing the interference of change board from outside, user can add wave filter in the joint of G1, S1, G2, S2. And if there is mechanical arm in the injection machine, user should add the wave filter near the change board.

The corresponding relation between change board and input end of frequency conveter.

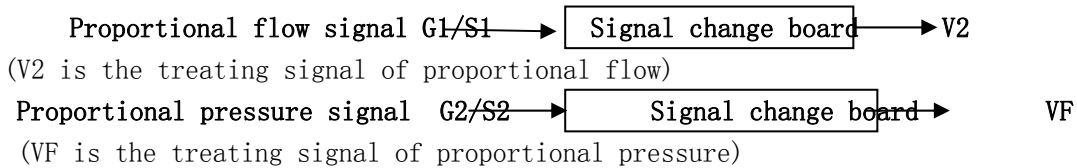

Note: Both of the proportional flow signal and proportional pressure signal are the DC current signal vary from 0—1A. When only connect one proportional signal, user should connect to the G1/S1 terminal. And it is need to regulate or change the parameter, user should regulate the parameter corresponding to V2. If these is necessary to connect another signal, user should connect it to G2/S2 terminal and correspondingly regulate or change the parameter to VF

Main parameter regulation

Code No.	Function	Recommend value
P0100	0:Front panel running 1:Terminal running	1
P0101		1
* P0102		1
* P0103	1(Single circuit) or8(Double circuit)	
P0105	accelerating time	1.0 (Sec.) (According to situation)
P0106	Decelerating time	1.0 (Sec.) (According to situation)
P0137	Acceleating and decelerating curve	0 ((According to situation)
P0207	Times of auto-reset from fault	10
P0208	Delay of auto-restart	2.0 (Sec.)
P0317	V2 input signal gain	(Regulate according to situation)
P0318	V2 input signal bias	(Regulate according to situation)
P0320	V2 Time constant of input wave filtering	0.00 (Sec.) Regulate according to situation)
* P0321	VF input signal gain	(Regulate according to situation)
* P0322	VF input singal bias	(Regulate according to situation)
* P0324	VF Time constant of input wave filtering	0.00 (Sec.) (Regulate according to situation)
P0329	Negative frequency set	0
P0151	Low limiting frequency selection	1

Mark * means the parameter need to change when two signal inputed in the same time.

Relative parameter regulatin note

P0137 Accelerating and decelerating curve

Selection0: linear acceleration and deceleration.

P0207Times of auto-reset from fault

P0208Delay of auto-restart

The parameter con guarantee the production continuity when the frequency inverter jump in case of fault.

P0317, P0318

When the frequency setting signal select (01-01) =1, use V2 (I2) input signal.

When the out V2 input voltage is 0.0V, setting value is -10.0%; When V2 input voltage is 10.0V 时, given value is 80.0, in other word : 03-18= -10.0,

03-17=80.0.

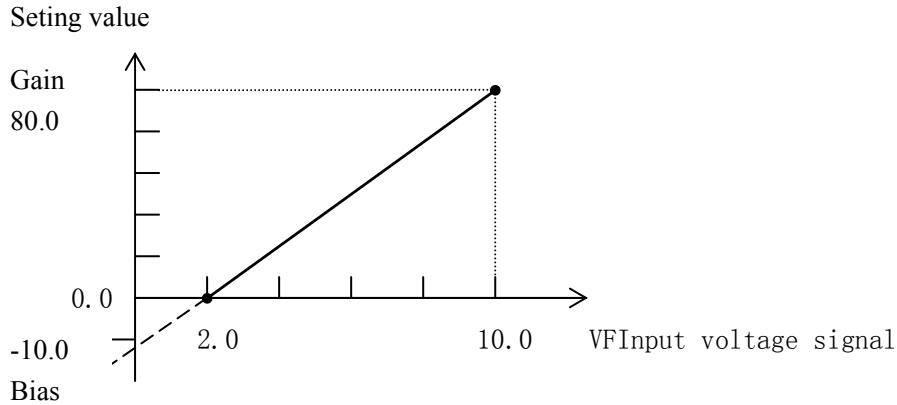

Analog input setting bias, means the percentage of setting value corresponding to min analog quantity input (0V) (03-18).

Analog input setting bias, means the percentage of setting value corresponding to max analog quantity input (10V) (03-17).

When analog signal used in frequency setting, 100% correspond to Max. input frequency.

For example : When use outside 0~10V output signal V2, the range of frequency regulating is 0.00Hz~50.00Hz, it can set the largest frequency (01-10) =50.0Hz, the upper limit frequency (01-07) =50.0Hz, Simulation inputs the type (03-19) =0, Simulation inputting and setovering (03-18) =0.0%, The simulation input signal gaining (03-17) =100.0%.

For example : When use outside 2~8V input signal, the range of frequency regulating is 0.00Hz~50.00Hz, it can set the largest frequency (01-10) =50.0Hz, the upper limit frequency (01-07) =50.0Hz, Simulation inputs the type (03-19) =0, Simulation inputting and setovering (03-18) = -33.3%, The simulation input signal gaining (03-17) =113.3%. Control connector VF-GND (0~10V) and IF-GND (0~20mA) are the same.

P0319, P0323

Choose the type of the input signal, can choose 0: 0-10V 1: 2-10V

P0320, P0324

Simulation inputs and strains the wave time constant, the set range :0.01~10.00s As to be strained waves to deal with by the simulation voltage or electric current signal that V2-GND and I2-GND inputting, in order to prevent frequently jumping the influence on the system of interfering signal changed. But strain wave time too long , will influence the sensitivity regulated .

Can choose : 0.00 - 0.20 seconds.

P0329

Analog input inversal selection: Set analog input ~output frequency straight line, run way of negative frequency , 0 represent negative frequency output is 0.00Hz, 1 represent negative frequency is inverse-frequency instruction. For injection machine application, choose 0.

P0151

Choose lower limit frequency:

This function establishes lower limit frequency and chooses the way.

Set 0: When frequency establishes the signal and is less than the establishing value of lower limit frequency (01-08), the frequency inverter still outputs lower limit frequency, the electrical machinery operates in accordance with lower limit frequency.

Set 1: When frequency establishes the signal and is less than the establishing value of lower limit frequency (01-08), the frequency inverter stops exporting, the electrical machinery stops operating.

When the moulding plastics machine is used, when the flow signal is minimum , the electrical machinery still operates at a low speed, can't stop , at this moment , can establish the frequency value of lower limit (01-08) and choose (01-51)=1, then the electrical machinery can stop rotating .

9 Options

This series of products can be installed the ancillary equipment additional by the user because of the service condition different from ones that require

9.1 AC reactor:

- 1、 AC reactor can suppress frequency inverter input high times of in harmony wave of electric current, obviously improve the power factor of the frequency inverter. Propose using and exchanging the reactor in case of the following.
- 2、 More than 10:1 that the frequency inverter is in a ratio of the capacity of power of its place being used and capacity of frequency inverter.
- 3、 Connect with silicon controlled rectifier load or the factor of power with control and compensate the device on the same power.
- 4、 The uneven degree of voltage of the three-phase power is relatively large. ($\geq 3\%$).

AC reactor of the daily specification

Voltage (V)	Power (kW)	Current (A)	Inductance (mH)	Voltage (V)	Power (kW)	Current (A)	Inductance (mH)
220	0.4	2.4	4.6	380	0.75	2.5	7.6
	0.75	4.5	2.4		1.5	4	4.8
	1.5	7	1.6		2.2	6	3.2
	2.2	11	1.0		3.7	9	2.0
	3.7	18	0.6		5.5	13	1.5
	5.5	22	0.5		7.5	17	1.2
	7.5	30	0.4		11	25	0.8
	11	42	0.27		15	32	0.6
	15	55	0.2		18.5	38	0.5
	18.5	70	0.16		22	45	0.42
	22	80	0.14		30	60	0.32
	30	110	0.1		37	75	0.26
	37	145	0.08		45	90	0.21
	45	180	0.06		55	110	0.18
	55	215	0.05		75	150	0.13
	75	285	0.04		93	170	0.11
	93	350	0.03		110	210	0.09
	110	415	0.03		132	250	0.08
					160	300	0.06
					185	350	0.06
			200	380	0.05		
			220	415	0.05		
			250	480	0.04		
			280	520	0.04		
			315	600	0.03		
			400	780	0.03		
			500	930	0.02		
			630	1200	0.01		

9.2 DC reactor DCL

When the capacity of the electric wire netting is far greater than the capacity of the frequency inverter or the capacity of power and greater than 1000KVA, or while expecting much in improving the factor of power of power supply, need to install the DC reactor additional. Direct current reactor used with AC reactor at the same time, have obvious result to high times of in harmony wave inputing to reduce.

The series of frequency inverter 93KW or above can use with DC reactor. And 75KW or lower can demand it when you order for the convenience of exchange of Pterminal.

DC reactor

Voltag e V	Power KW	Curre nt A	Induc tion μ H	Voltag e V	Power KW	Current A	Induc tion μ H
220	11~15	75	450	380	11~15	40	1500
	18.5~30	150	200		18.5~30	75	600
	37~55	300	100		37~55	150	300
	75~90	420	40		75~90	220	200
	110	560	25		110~132	280	140
					160~200	370	110
					220	560	70
					250~280	740	55
					315~400	900	35
					450~630	1200	20

9.3 Radio noise wave filter

The radio noise wave filter is used for suppressing conduction of electromagnetism interferin noise produced by frequency inverter, suppressing external radio interference and lash, surge instantaneously interference to this machine .

Three-phase and three line radio noise wave filter in commonly used

Voltag e (V)	Motor power (kW)	Voltag e (V)	Motor power (kW)	Wave filter model	Wave filter main parameter					
					Common mode input loss dB			Differential mode input loss dB		
					0.1MHz	1MHz	30MHz	0.1MHz	1MHz	30MHz
220	0.4~0.75	380	0.75~1.5	DL-5EBT1	75	85	55	55	80	60
	1.5~2.2		2.2~3.7	DL-10EBT1	70	85	55	45	80	60
	3.7~5.5		5.5~7.5	DL-20EBT1	70	85	55	45	80	60
	7.5		11~15	DL-35EBT1	70	85	50	40	80	60
	11~15		18.5~22	DL-50EBT1	65	85	50	40	80	50
	18.5~22		30~37	DL-80EBT1	50	75	45	60	80	50
	30		45	DL-100EBK1	50	70	50	60	80	50
	37		55~75	DL-150EBK1	50	70	50	60	70	50
	45~55		93~110	DL-200EBK1	50	70	60	60	70	50

Occasion of using of expecting much and demanding to accord with CE , UL , CSA standard in preventing radio interference, or there are equipment of anti-interference with insufficient ability ,etc. under the situation around the frequency inverter, should use this wave filter . Should notice wiring is it shorten to try one's best when the installation, wave filter should try one's best close to the frequency inverter also.

9.4. Remote operation board

Design exquisite operation plates easy to use on the panel of this serial frequency inverters. If user need to guide operation board to other place can buy additional line only need to propose while ordering. Operate record with adopt serial communication way by host computer , so user can operate record move to from place within the host computer 10m, if need larger distance , can buy remote operation board from the supplier or our company and operate one .

9.5 Resuscitation brake unite and resuscitation brake resistance

The model of 7.5KW or lower all are place inside with resuscitation brake unite, and if you need to increase the torque, only connect the outside resisatance. And model of 11kW or above have no this function, if need this function should connect brake unite. If the braking torque is 100%, usual specification' s braking resistance value and power as fellows:

Voltage V	Motor power KW	Resistance value Ω	Resistance power KW	Voltage V	Motor power KW	Resistance value Ω	Resistance power 率 KW
220	0.75	200	0.1	380			
	1.5	100	0.25		1.5	400	0.25
	2.2	75	0.25		2.2	250	0.25
	3.7	40	0.4		3.7	150	0.4
	5.5	30	0.5		5.5	100	0.5
	7.5	20	0.8		7.5	75	0.8
	11	13.6	2.25		11	50	1
	15	10	3		15	40	1.5
	18.5	8	4		18.5	30	4
	22	6.8	4.5		22	30	4
	30	5	6		30	20	6
	37	5	6		37	16	9
	45	6.8/2	9		45	13.6	9
	55	6.8/2	9		55	20/2	12
	75	6.8/3	13.5		75	13.6/2	18
	90	6.8/3	13.5		90	20/3	18
110	6.8/4	18	110	20/3	18		
				132	20/4	24	
				160	13.6/4	36	
				185	13.6/5	45	
				200	13.6/5	45	
				250	13.6/6	54	
				315	13.6/6	54	

Above is according to 5% ED, 15 second continuous braking time.

9.6 Leakage protector

Because the static capacity to ground existed in the output and input leading wire and inside frequency inverter and motor and the and because the inverter is low noise type and load wave frequency is high, so the leakage current is much higher especially to large capacity type and even more will lead to misoperation in protection circuit. If you meet this kind of problem, you can low the load wave frequency, short leading wire, and install leakage protector. And when using leakage protector, should note:

- Leakage protector should install by the input of frequency protector and it is better to install after MCCB(without fuse circuit breaker).
- The operating current of leakage protector should be 10 fold larger than the leakage current(total of cuicuit, radio noise filter, motor etc.) of the circuit without using conveter.