

## Preface

Thank you for choosing the AT550 series of AC Drives developed by JACT Electric Co., Ltd. JACT designs and manufactures the AT550 Series of AC Drives for the industrial automation applications and focus on product quality improvement by launching the policy of continuous product development and gradual improvement.

The AT550 is a high-performance and multipurpose industrial product aiming to integrate synchronous motor drive with asynchronous motor drive, and torque control, speed control with position control. It is designed with advanced vector control technology and the latest digital processor dedicated for motor control, thus enhancing product reliability and adaptability to the environment.

The AT550 adopts customized and industrialized design to realize excellent control performance through optimized functions and flexible applications.

AT550 uses high power density design. Some power ranges carry built-in DC reactor and brake unit to save installation space. Through overall EMC design, it can satisfy the low noise and low electromagnetic interference requirements to cope with challenging grid, temperature, humidity and dust conditions, thus greatly improving product reliability.

This operation manual presents installation wiring, parameter setup, fault diagnosis and trouble shooting, and precautions related to daily maintenance. Read through this manual carefully before installation to ensure the AC Drive is installed and operated in a proper manner to give full play to its excellent performance and powerful functions.

It is the responsibility of the user or machine builder or installation contractor or electrical designer/engineer to take all necessary precautions to ensure that the system complies with current standards, and to provide any devices (including safety components), required to ensure the overall safety of the equipment and personnel.

If there is any doubt with regards to the software version or the manual contents, please contact us.

## Safety Information and Precautions

### Safety definition



#### DANGER

It is essential for avoiding a safety hazard. Serious physical injury or even death may occur if related requirements are not followed.



#### WARNING

It is necessary for avoiding a risk of damage to the product or other machine.



#### WARNING

As high voltage still presents in the bus capacitor after power off, wait for at least five minutes (or 15 min / 25 min, depending on the warning symbols on the machine) after power off to prevent electric shock.

### Electrical Safety

Extreme care must be taken at all times when working with the AC Drive or within the area of the AC Drive. The voltages used in the AC Drive can cause severe electrical shock or burns and is potentially lethal. Only professional and qualified personnel should be allowed to work on AC Drives. Read the operation manual before operating on the equipment.

The guidelines and recommendations should be followed in order to gain long term trouble free operation as the lifetime of the AC Drive is dependent on the working environment and correct handling of the product in the initial installation stage.

### Delivery and installation

Select appropriate tools for delivery and installation to ensure a safe and proper running of the AC Drive and avoid physical injury or death. To ensure physical safety, the installation staff should take mechanical protective measures, wearing exposure shoes and working uniforms;

R, S and T are the power input terminals, and U, V and W are output motor terminals. Connect the input power cables and motor cables properly; otherwise, damage to the AC Drive may occur. Connect the optional brake parts (brake resistors, brake units or feedback units) according to the wiring diagram. Do not touch the AC Drive with wet items or body parts; otherwise, electric shock may occur.

When using an earth leakage circuit breaker, use a residual current operated protective device (RCD) of type B (breaker which can detect both AC and DC). Leakage current can cause unprotected components to operate incorrectly. If this is a problem, lower the carrier frequency, replace the components in question with parts protected against harmonic current, or increase the sensitivity amperage of the leakage breaker to at least 200 mA per drive.

## Adjusting AC Drive Parameters

Disconnect all power sources applied to the AC Drive before terminal wiring, and wait for at least the time designated on the AC Drive after disconnecting the power sources.

High voltage presents inside the AC Drive during running. Do not carry out any operation on the AC Drive during running except for keypad setup.

This manual provides a complete list of the parameters with functional description and care should always be taken whenever parameters are adjusted during a live running startup. JACT can provide product training and if in doubt seek advice.

## Maintenance and component replacement

Only well-trained and qualified professionals are allowed to perform maintenance, inspection, and component replacement on the AC Drive.

Take measures to prevent screws, cables and other conductive matters from falling into the AC Drive during maintenance and component replacement.

Do not perform wiring, inspection or component replacement when power supply is applied. Ensure all the input power supplies are disconnected before wiring and inspection, and wait for at least the time designated on the AC Drive or until the DC bus voltage is less than 36V. The minimum waiting time is listed in the table below.

AC Drive Model	Minimum waiting time
0.75kW-110kW	5min
132kW-315kW	15min
Above 355kW	25min

# Contents

Preface.....	- 1 -
Safety Information and Precautions.....	- 2 -
Contents.....	- 4 -
Chapter 1 Product Information.....	- 5 -
1.1 Product Type Identification.....	- 5 -
1.2 Product Nameplate.....	- 5 -
1.3 AT550 Inverter Series.....	- 6 -
1.4 Product Description.....	- 7 -
1.6 Product Appearance and Dimensions.....	- 10 -
1.7 Keyboard Appearance and Dimensions.....	- 13 -
1.8 Appearance and Hole Size of the Keyboard Tray.....	- 13 -
1.9 Appearance and Dimensions of the Double Display Keyboard and Tray.....	- 14 -
Chapter 2 Mechanical Installation.....	- 15 -
2.1 Installation Environment.....	- 15 -
2.2 Installation Space and Directions.....	- 15 -
2.3 Dismantling of the Cover Plate.....	- 17 -
Chapter 3 Electrical Installation.....	- 18 -
3.1 Electrical Installation.....	- 18 -
3.2 Description of Peripheral Electrical Devices.....	- 19 -
3.3 Peripheral Electrical Components Selection Guidance.....	- 20 -
3.4 Selection of Braking Unit and Braking Resistor.....	- 20 -
3.5 Selection of Expansion Card.....	- 22 -
3.6 Wiring Method.....	- 23 -
Chapter 4 Keyboard and Display.....	- 36 -
4.1 Operation and Display Interface.....	- 36 -
4.2 Keyboard Indicators Description.....	- 37 -
4.3 Keyboard Button Description.....	- 37 -
4.4 Viewing and Modifying Function Codes.....	- 37 -
4.5 Selecting Menu Mode.....	- 38 -
Chapter 5 Basic Operation and Test Run.....	- 39 -
5.1 Quick Adjustment Guidance.....	- 39 -
5.2 Precautions Before Power-On.....	- 40 -
5.3 Display Status After Power-On.....	- 40 -
5.4 Motor Control Methods Selection.....	- 40 -
5.5 Initialization of Parameters.....	- 42 -
5.6 Operation Commands Source Selection.....	- 42 -
5.7 Frequency Source Selection.....	- 43 -
5.8 Stop Modes Selection.....	- 45 -
5.9 Observation of Operation Status via DO and AO.....	- 45 -
Chapter 6 Function Parameter List.....	- 46 -
Chapter 7 Function Parameter List.....	- 75 -
Chapter 8 Maintenance and Troubleshooting.....	- 97 -
8.1 Daily Maintenance and Inspection of AT550.....	- 122 -
8.2 Warranty.....	- 123 -
8.3 Faults and Solutions.....	- 123 -
Appendix A: MODBUS Communication Protocol.....	- 129 -
1.1 Protocol Contents.....	- 129 -
1.2 Communication Frame Description.....	- 129 -
1.3 Communication Data Address Definition.....	- 132 -
1.4 Description of Group FD Communication Parameters.....	- 134 -

# Chapter 1 Product Information

## 1.1 Product Type Identification

This is an example of the nameplate of standard AT550 products.

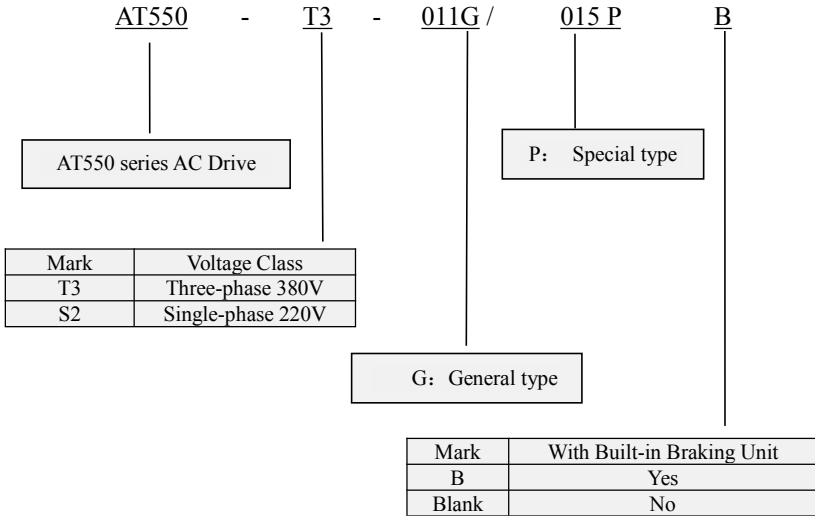

Figure 1.1 Product Model Name

## 1.2 Product Nameplate

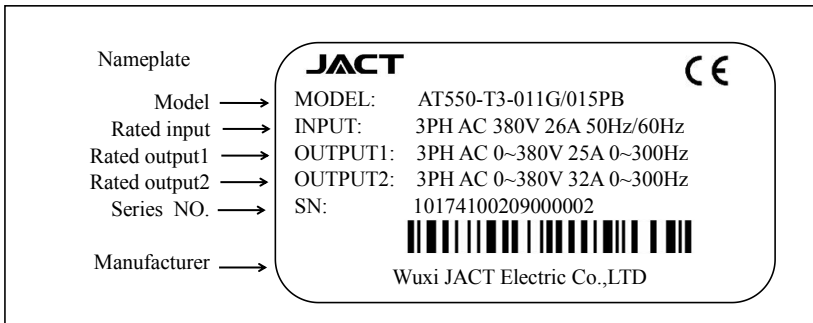

Figure 1.2 Product type identification

Note:

Built-in brake unit is included in standard configuration of 380V 22kW and below models; Brake unit is not included in standard configuration of 380V 30kW and 37kW models (optional built-in brake unit is available, suffix "-B" indicates optional built-in brake unit).

### 1.3 AT550 Inverter Series

Product Model	Input current (A)	Output current (A)	Motor (kW)
AT550-S2-0R4GB	5.4	2.3	0.4
AT550-S2-0R7GB	8.2	4	0.75
AT550-S2-1R5GB	14	7	1.5
AT550-S2-2R2GB	23	9.6	2.2
Product Model	Input current (A)	Output current (A)	Motor (kW)
AT550-T3-0R7G/1R5PB	3.4	2.1	0.75
AT550-T3-1R5G/2R2PB	5	3.8	1.5
AT550-T3-2R2G/4R0PB	5.8	5.1	2.2
AT550-T3-4R0G/5R5PB	10.5	9	3.7
AT550-T3-5R5G/7R5PB	14.6	13	5.5
AT550-T3-7R5G/011PB	20.5	17	7.5
AT550-T3-011G/015PB	26	25	11
AT550-T3-015G/018PB	35	32	15
AT550-T3-018G/022PB	38.5	37	18.5
AT550-T3-022G/030PB	46.5	45	22
AT550-T3-030G/037P	62	60	30
AT550-T3-037G/045P	76	75	37
AT550-T3-045G/055P	92	91	45
AT550-T3-055G/075P	113	112	55
AT550-T3-075G/090P	157	150	75
AT550-T3-090G/110P	180	176	90
AT550-T3-110G/132P	214	210	110
AT550-T3-132G/160P	256	253	132
AT550-T3-160G/185P	307	304	160
AT550-T3-200G/220P	385	377	200
AT550-T3-220G/250P	430	426	220
AT550-T3-250G/280P	468	465	250
AT550-T3-280G/315P	525	520	280
AT550-T3-315G/355P	590	585	315
AT550-T3-355G/400P	665	650	355
AT550-T3-400G/450P	785	725	400
AT550-T3-450G	883	820	450
AT550-T3-500G	910	900	500
AT550-T3-560G	1100	1020	560
AT550-T3-630G	1160	1120	630
AT550-T3-710G	1171	1260	710

Table 1.1 AT550 Models and Specs

### 1.4 Product Description

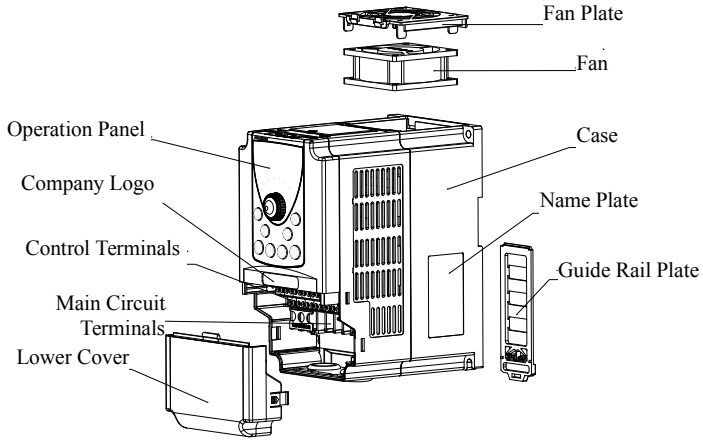

Figure 1.3 Components of Plastic Case Model

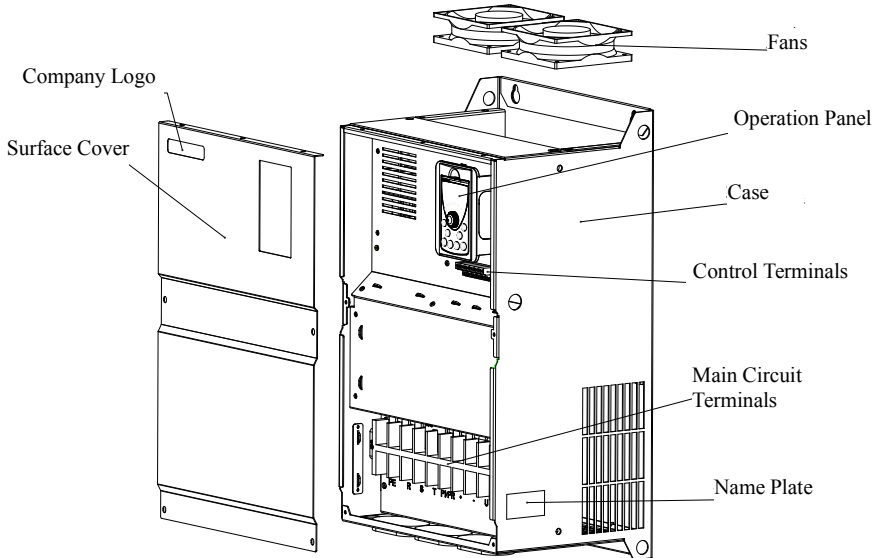

Figure 1.4 Components of the Metallic Case Model

## 1.5 Technical Specifications

Table 1.2 Technical Specifications of AT550

Item		Specification
Standard functions	Maximum frequency	320Hz
	Carrier frequency	0.5kHz~16.0kHz The carrier frequency is automatically adjusted based on the temperature
	Input frequency resolution	Digital setting:0.01Hz Analog setting:maximum frequency×0.025%
	Control mode	Voltage/Frequency(V/F) control Switching vector control (SVC) Forward vector control (FVC)
	Startup torque	G type: 0.5Hz/150% (SVC); 0Hz/180% (FVC) P type: 0.5Hz/100%
	Speed range	1:100(SVC)                      1:1000(FVC)
	Speed stability accuracy	±0.5%(SVC)                      ±0.02%(FVC)
	Torque control accuracy	±0.5% (FVC)
	Overload capacity	G type: 60s for 150% of rated current and 3s for 180% of rated current P type: 60s for 120% of rated current and 3s for 150% of rated current
	Torque boost	Automatic torque boost Manual torque boost 0.1%~30.0%
	V/F curve	Straight-line V/F curve Multi-point V/F curve Square V/F curve
	Ramp mode	Straight-line ramp S-curve ramp Four groups of acceleration/deceleration time with the range of 0.0~6500.0s
	DC braking	DC braking frequency: 0.00Hz to max.frequency Braking time: 0.0~100.0s Braking action current value: 0.0%~100.0%
	JOG control	JOG frequency range: 0.00~50.00 Hz JOG acceleration/deceleration time: 0.0~6500.0s
	Simple PLC, multiply speed running	The system implements up to 16 speeds by using simple PLC function or by using digital input signals.
	Onboard PID	It implements the closed-loop process control system easily.
	Auto voltage regulation (AVR)	The system maintains a constant output voltage automatically when the grid voltage changes through the permissible range.
Standard functions	Overvoltage& Overcurrent stall control	The current and voltage are limited automatically during the running process so as to avoid frequent tripping due to overvoltage and overcurrent.
	Rapid current limit	It decreases the overcurrent faults to the minimum and ensures normal running of the AC drive.



	Torque limit and control	It can limit the torque automatically and prevent frequent overcurrent tripping operation. Torque control is applied in vector control mode.
Individualized functions	High performance	high-performance current vector control technology.
	Power dip ride-through	Load feedback energy compensates for any voltage reduction, allowing the drive to continue to operate for a short time during power dips.
	Timing control	Time range: 0.0–6500.0 minutes
	Field bus	Modbus-RTU protocol (485)
Running	Running command source	<ul style="list-style-type: none"> <li>• Operation panel control</li> <li>• Terminal control</li> <li>• Communication control</li> </ul> Allows different methods of switching between command sources:
	Frequency setting channel	Supports up to 13 frequency reference setting channels and allows different methods of switching between frequency reference setting channels: Digital setting Analog voltage reference Analog current reference Pulse reference Communication reference
	Auxiliary frequency setting channel	Supports up to 10 auxiliary frequency sources, and allows fine tuning of the auxiliary frequency and main & auxiliary calculation.
	Input terminals	5 digital input (DI) terminals, X5 supports up to 100 kHz high-speed pulse input; 2 analog input (AI) terminals, AI1 only supports 0–10 V voltage input and AI2 supports 0–10 V voltage input or 4–20 mA current input.
	Output terminals	1 high-speed pulse output terminal (open-collector) that supports 0–100 kHz square wave signal output 1 digital output (DO) terminal 2 relay output terminals (One is factory default, the other is optional) 2 analog output (AO) terminals that supports 0–20 mA current output or 0–10 V voltage output.
Display & operate panel	LED display	Display parameters (three display modes: Basic mode, Quick menu mode, Non-factory value mode).
	Protection function	Phase loss protection; Instantaneous overcurrent protection; overheat protection; Short-circuit protection; overvoltage protection; undervoltage protection; overload protection; overcurrent protection;
	Optional parts	Braking unit, I/O and AI extension card, field bus communication card, differential input PG card, OC input PG card, sin/cos PG card.

Environ- ment	Installation location	Indoor, free from direct sunlight, dust, corrosive gas, combustible gas, oil smoke, vapour, drip or salt.
	Altitude	Lower than 1000 m (de-rated if higher than 1000 m)
	Ambient temperature	-10°C to +40°C (de-rated if the ambient temperature is between 40°C and 50°C).
	Humidity	Less than 95%RH, without condensing
	Vibration	Less than 5.9 m/s <sup>2</sup> (0.6 g)
	Storage temperature	-20°C~+60°C

### 1.6 Product Appearance and Dimensions

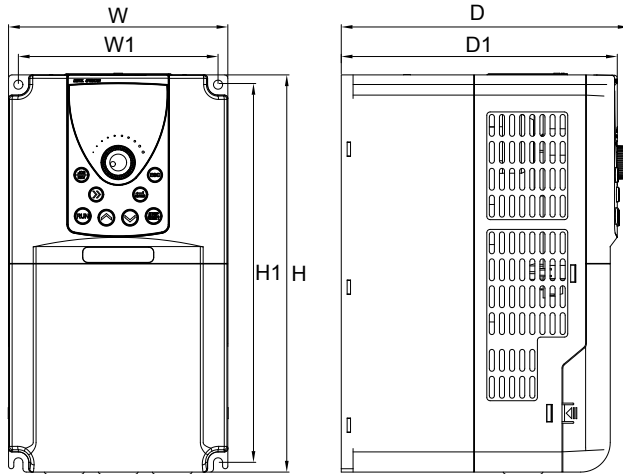

Figure 1.5 Plastic Case Mounting Dimensions

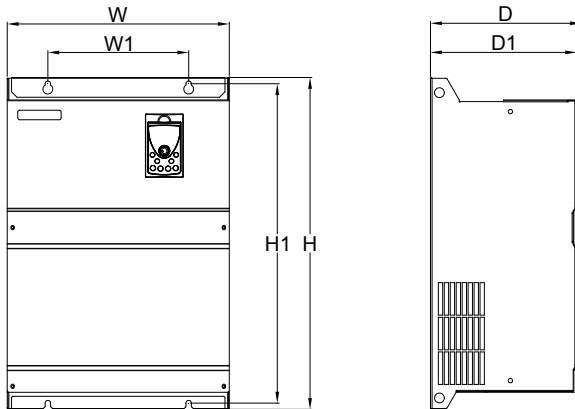

Figure 1.6 Metallic Case Mounting Dimensions

Model	Mounting Holes Position		Dimensions				Diameter of Mounting Holes
	W1	H1	H	W	D1	D	
AT550-S2-0R7GB	71.5	121.5	132	80	105.5	114.6	φ4.5
AT550-S2-1R5GB							
AT550-S2-2R2GB	88.4	168.4	180	100	152	159	φ5.5
AT550-T3-0R7G/1R5PB							
AT550-T3-1R5G/2R2PB							
AT550-T3-2R2G/4R0PB							
AT550-T3-4R0G/5R5PB	118.4	224.5	236	130	163.5	170.5	φ5.5
AT550-T3-5R5G/7R5PB							
AT550-T3-7R5G/011PB	141	243	260	155	175	182	φ7
AT550-T3-011G/015PB							
AT550-T3-015G/018PB	190	273.5	291.5	197	175	182	φ6
AT550-T3-018G/022PB							
AT550-T3-022G/030PB							
AT550-T3-030G/037P	220	392	405	253	180	187	φ7
AT550-T3-037G/045P							
AT550-T3-045G/055P	260	555	575	340	250	259	φ10
AT550-T3-055G/075P							
AT550-T3-075G/090P	260	590	610	410	270	279	φ10
AT550-T3-090G/110P							
AT550-T3-110G/132P	320	690	720	455	325	334	φ12
AT550-T3-132G/160P							
AT550-T3-160G/185P	360	845	880	530	367	376	φ14
AT550-T3-200G/220P							
AT550-T3-220G/250P	480	1005	1040	650	411	420	φ14
AT550-T3-250G/280P							
AT550-T3-280G/315P							
AT550-T3-315G/355P	600	1252	1300	815	427	436	φ14
AT550-T3-355G/400P							
AT550-T3-400G/450P							
AT550-T3-450G							

### 1.6.2 Cabinet Installation Dimensions

Figure 1.7 Installation Diagram

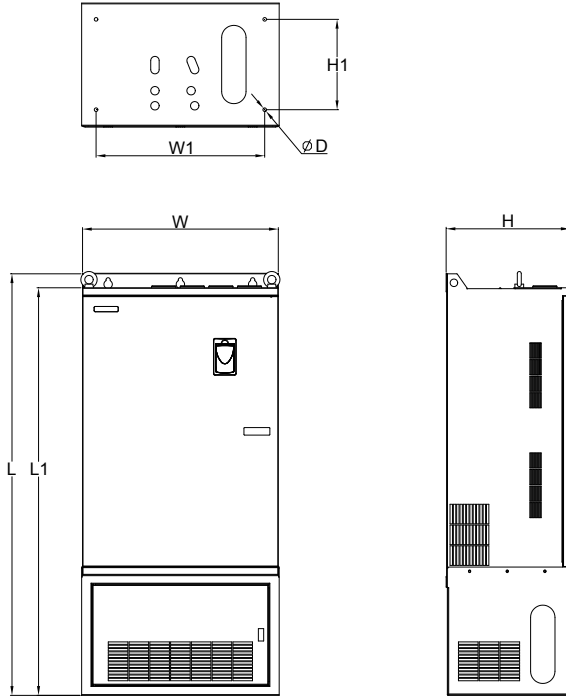

Figure 1.8 Cabinet Installation Dimensions

Model	Appearance Dimensions (mm)				Installation Dimensions		Diameter of Mounting Holes
	H	W	L	L1	H1	W1	
AT550-T3-045G/055P	249	340	850	810	180	280	$\phi 12$
AT550-T3-055G/075P							
AT550-T3-075G/090P							
AT550-T3-090G/110P	265	416	880	840	190	350	$\phi 10$
AT550-T3-110G/132P							
AT550-T3-132G/160P	327	461	980	935	220	380	$\phi 12$
AT550-T3-160G/185P							
AT550-T3-200G/220P	367	536	1190	1142	290	460	$\phi 12$
AT550-T3-220G/280P							
AT550-T3-280G/315P	412	656	1400	1354	300	560	$\phi 12$
AT550-T3-315G/400P							
AT550-T3-400G/450P	428	815	1757	1702	300	730	$\phi 12$
AT550-T3-450G							
AT550-T3-500G	600	1150	1900	/	480	1050	$\phi 18$
AT550-T3-560G							
AT550-T3-630G	600	1310	2208	/	480	1210	$\phi 18$
AT550-T3-710G							

### 1.7 Keyboard Appearance and Dimensions

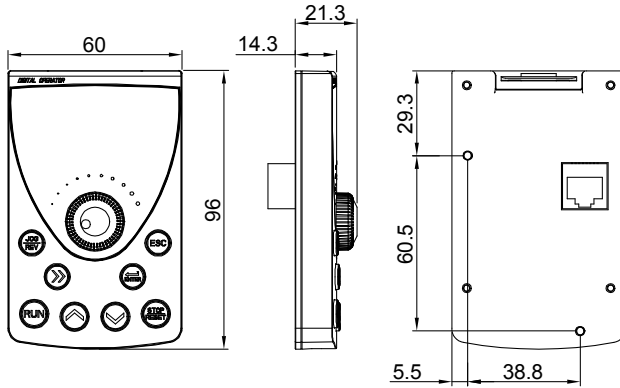

Figure 1.9 Appearance and Dimensions of the Keyboard (mm)

### 1.8 Appearance and Hole Size of the Keyboard Tray

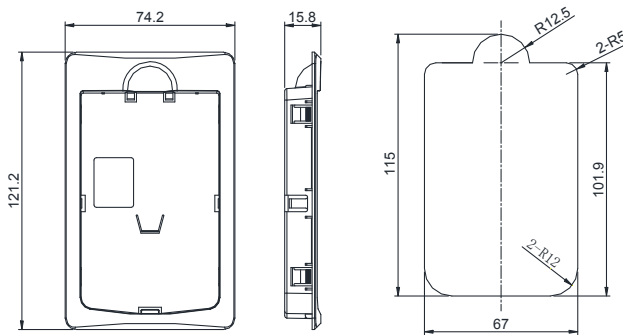

Figure 1.10 Keyboard Tray Appearance and Hole Size (mm)

### 1.9 Appearance and Dimensions of the Double Display Keyboard and Tray

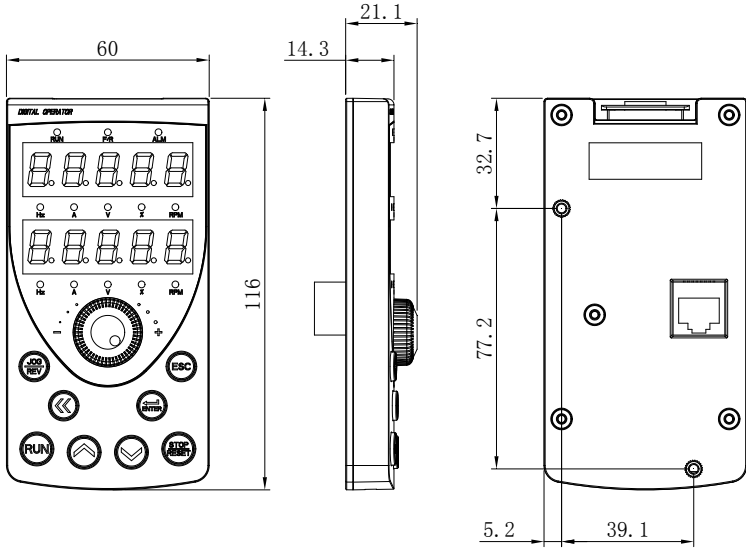

Figure 1.11 Appearance and Dimensions of the Double Display Keyboard

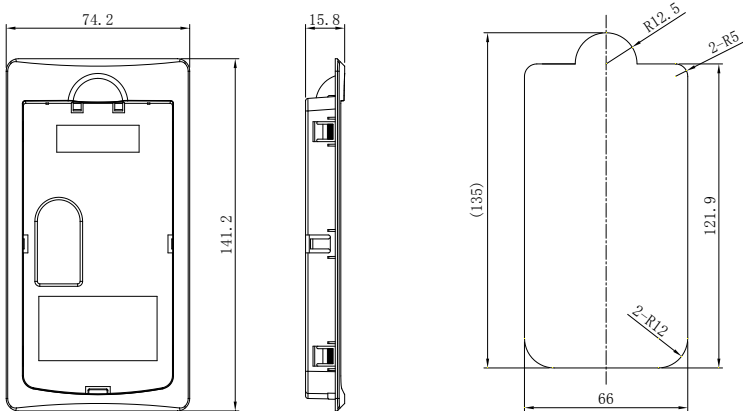

Figure 1.12 Appearance and Dimensions of the Double Display Keyboard and Tray

Dimensions of the Tray

Hole Sizes of the Tray  
(Square Hole 129.5mm\*66mm)

## Chapter 2 Mechanical Installation

### 2.1 Installation Environment

1. Ambient Temperature: The temperature affects the life of product. It is prohibited to run the product out of ambient temperature range (-10°C~50°C).
2. Please install the product on flame retardants and mount it vertically on mounting brackets using bolts or screws. Be sure to allow sufficient space around the inverter for heat dissipation since it generates heat while running.
3. Please install the inverter on a flat surface where the vibration should remain lower than 0.6g, away from punches, etc.
4. Avoid installing the inverter under direct sunlight or in humid places.
5. Avoid installing the inverter in places of corrosive, flammable and explosive gas.
6. Avoid installing the inverter in places full of oil, dust and metal particles.

### 2.2 Installation Space and Directions

2.2.1 Single Inverter Installation: the installation and insulation space for an inverter has to be left out based on its different power ratings.

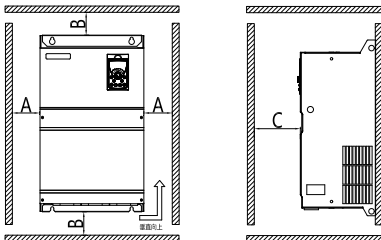

Power level	Size Requirements		
0.75kW-22kW	A ≥ 10mm	B ≥ 100mm	C ≥ 40mm
30kW-37kW	A ≥ 50mm	B ≥ 200mm	C ≥ 40mm
45kW-75kW	A ≥ 50mm	B ≥ 200mm	C ≥ 40mm
90kW-710kW	A ≥ 50mm	B ≥ 200mm	C ≥ 40mm

2.2.2 Multiple Inverters Installation: Inverters dissipate from bottom to top. Therefore, when multiple inverters are operating, they are usually installed side by side and aligned to top, especially for different sizes of inverters.

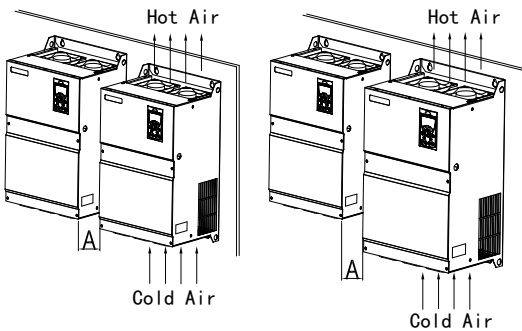

Power level	Size Requirements
0.75kW-22kW	A ≥ 10mm
30kW-37kW	A ≥ 50mm
45kW-75kW	A ≥ 50mm
90kW-710kW	A ≥ 50mm

2.2.3 Multiple Inverters Installed Vertically: In occasions where multiple inverters need installed vertically next to each other, the lower row of inverters' dissipation of heat will cause a temperature rise of the upper row of inverters, resulting in the overheat/overload errors of the upper row of inverters. Therefore, it is recommended to take measures such as installing an insulation plate in between as the following figure:

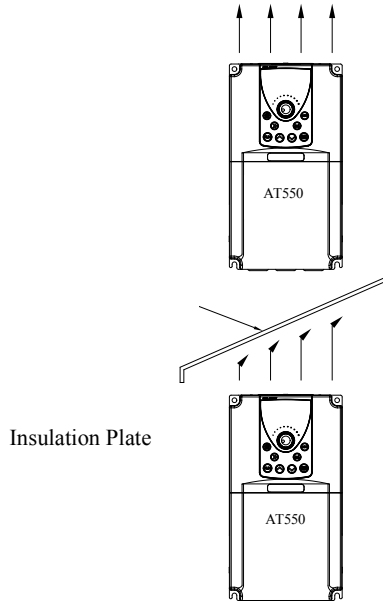

Figure 2.1 Inverter Installation Diagram

Note: Please install an insulation plate according to the figure above when installing two inverters vertically next to each other.

#### Attention Matters for Heat Dissipation of Mechanically Mounting:

- 1) The inverter should be installed vertically for heat dissipation but cannot be put upside down. Installing the inverters side by side is highly recommended for installing a number of them in one cabinet. Please refer to figure 3-1 when installing the insulation plate
- 2) Follow Figure3.1 to ensure the dissipation space for the inverters. The heat dissipation of other machines in the cabinet should be considered as well.
- 3) The mounting bracket must be flame retardant material.
- 4) Installing the radiator outside the cabinet is recommended if there are metal dusts at the installation location. Please make sure the sealed cabinet space is as large as possible.



### 2.3 Dismantling of the Cover Plate

1. Press inward to disconnect the hook from the hook slot.

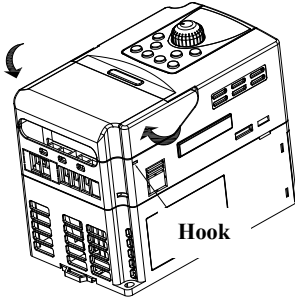

2. Lift the cover to open the inverter.

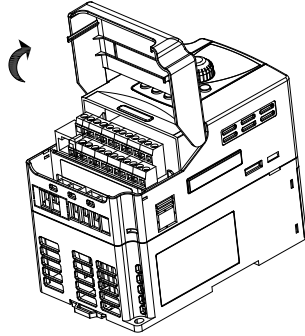
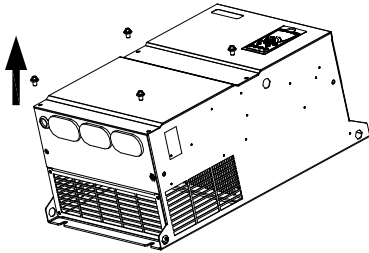

Figure 2.2 Remove the Cover Plate (Plastic Case)

1. Loosen the screws.



2. Lift the cover to open the inverter.

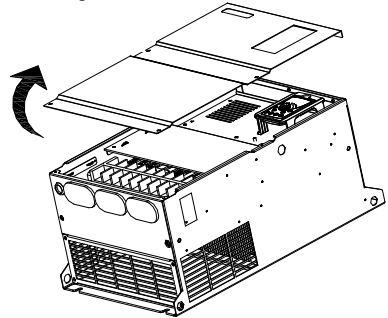

Figure 2.3 Remove the Cover Plate (Metallic Case)

# Chapter 3 Electrical Installation

## 3.1 Electrical Installation

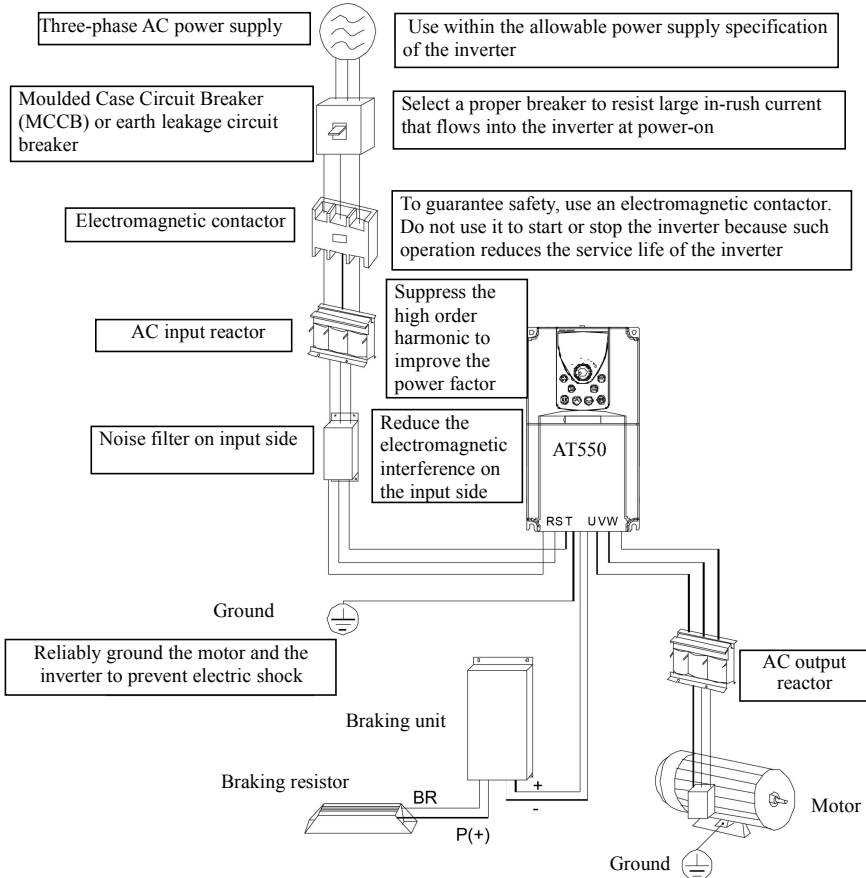

Figure 3.1 Peripheral Electrical Devices

- Do not install capacitors or surge suppressor on the output side of the inverter, which will lead to a breakdown or cause damage to the capacitor or the surge suppressor.
- Input/Output (Major Loop) of the inverter contains harmonics, which may interfere with the communication devices connected to the inverter. Therefore, anti-interference filters are recommended to install in order to minimize the interference.
- Please refer to the selection manual of peripheral equipment for more details of peripheral devices and options.

### 3.2 Description of Peripheral Electrical Devices

Items	Function Descriptions
MCCB	Disconnect the power supply when over current occurs on downstream devices
Residual Current Circuit Breaker (RCCB)	Since the output of the inverter is high-frequency pulse voltage, high-frequency leakage occurs sometimes; When installing an RCCB on the input side, it is recommended to choose the special-use RCCB. It is suggested to choose the model “B” for RCCB, and the leakage current is set to 300mA.
Contactor	Start and stop the inverter. Avoid starting and stopping the inverter frequently by switching the contactor on and off (less than twice per minute) nor use it to directly start the inverter.
EMC Input Filter	<ul style="list-style-type: none"> <li>• Reduce the external conduction and radiation interference of the inverter.</li> <li>• Decrease the conducting interference flowing from the power terminals to the inverter and improve the anti-interference capability of the inverter.</li> </ul>
AC Input Reactor	<ul style="list-style-type: none"> <li>• Improve the power factor of the input side;</li> <li>• Eliminate the higher harmonics generation on the input side effectively and prevent other devices from being damaged due to distortion of the voltage waveform.</li> <li>• Eliminate the imbalance among the power phases that causes the imbalance of input current.</li> </ul>
DC Reactor	<ul style="list-style-type: none"> <li>• Improve the power factor of the input side.</li> <li>• Improve the efficiency and thermal stability of the inverter.</li> <li>• Eliminate the impact of higher harmonics of the inverter input side and reduce the external radiation and interference.</li> </ul>
AC Output Reactor	<p>The output side of the inverter generally has much higher harmonics. When the motor is far from the inverter, there is distributed capacitance in the circuit and certain harmonics may cause resonance in the circuit, bringing the following two effects:</p> <ul style="list-style-type: none"> <li>• Impair the motor insulation performance and damage the motor on the long run.</li> <li>• Generate large leakage current and cause frequent protection of tripping on the inverter. If the distance between the inverter and the motor is greater than 100 m, an AC output reactor is recommended.</li> </ul>

Table 3.1 Description of Peripheral Electrical Devices

### 3.3 Peripheral Electrical Components Selection Guidance

Converter model	MCCB (A)	Contactora (A)	Power Input Cable (mm <sup>2</sup> )	Power Output Cable (mm <sup>2</sup> )	Control Circuit Wirings (mm <sup>2</sup> )
AT550-S2-0R4GB	10	9	0.75	0.75	0.5
AT550-S2-0R7GB	16	12	0.75	0.75	0.5
AT550-S2-1R5GB	25	18	1.5	1.5	0.5
AT550-S2-2R2GB	32	25	2.5	2.5	0.5
AT550-T3-0R7G/1R5PB	6	9	0.75	0.75	0.5
AT550-T3-1R5G/2R2PB	10	9	0.75	0.75	0.5
AT550-T3-2R2G/4R0PB	10	9	0.75	0.75	0.5
AT550-T3-4R0G/5R5PB	16	12	1.5	1.5	0.5
AT550-T3-5R5G/7R5PB	20	18	2.5	2.5	0.75
AT550-T3-7R5G/011PB	32	25	4.0	4.0	0.75
AT550-T3-011G/015PB	40	32	4.0	4.0	0.75
AT550-T3-015G/018PB	50	38	6.0	6.0	0.75
AT550-T3-018G/022PB	50	40	10	10	1.0
AT550-T3-022G/030PB	63	50	10	10	1.0
AT550-T3-030G/037P	100	65	16	16	1.0
AT550-T3-037G/045P	100	80	25	25	1.0
AT550-T3-045G/055P	125	95	35	35	1.0
AT550-T3-055G/075P	160	115	50	50	1.0
AT550-T3-075G/090P	225	170	70	70	1.0
AT550-T3-090G/110P	250	205	95	95	1.0
AT550-T3-110G/132P	315	245	120	120	1.0
AT550-T3-132G/160P	350	300	120	120	1.0
AT550-T3-160G/185P	400	300	150	150	1.0
AT550-T3-200G/220P	500	410	185	185	1.0
AT550-T3-220G/250P	630	475	2*120	2*120	1.0
AT550-T3-250G/280P	630	475	2*120	2*120	1.0
AT550-T3-280G/315P	700	620	2*120	2*120	1.0
AT550-T3-315G /355P	800	620	2*150	2*150	1.0
AT550-T3-355G /400P	1000	800	2*185	2*185	1.0
AT550-T3-400G /450P	1250	800	2*240	2*240	1.0
AT550-T3-450G	1250	1000	2*240	2*240	1.0
AT550-T3-500G	1600	1000	2*300	2*300	1.0
AT550-T3-560G	1600	1250	2*300	2*300	1.0
AT550-T3-630G	2000	1600	2*300	2*300	1.0
AT550-T3-710G	2500	2000	2*300	2*300	1.0

### 3.4 Selection of Braking Unit and Braking Resistor

#### ◆ Value selection of the Braking Resistor

The AC drive transfers regenerative energy generated during braking of motor to external braking resistor.

According to the formula  $U^* U/R = Pb$ :

- U: the braking voltage at system stable braking.
- U: value varies with the system. The 380 VAC power system usually selects 700 V braking
- Pb: braking power.

#### ◆ Power selection of the Braking Resistor

In theory, power of braking resistor is the same as braking power. But in consideration of de-rating, power of braking resistor is calculated from the following formula: according to the formula  $:0.7 * Pr = Pb * D$ .

- Pr: the power of resistor.
- D: the braking frequency (percentage of the regenerative process to the whole working process)

Common Applications	Elevator	Uncoiling and Coiling	Centrifuge	Accidental Braking Load	General Occasions
Selection of the Breaking Frequency	20%-30%	20%-30%	50%-60%	5%	10%

The following table provides data for reference. User may select different resistance and power based on their actual needs. However, the value of resistance must not be greater than the recommended value. The power may be larger than the recommended value.

The braking resistor model depends on the generation power of the motor in the actual system and is also related to the system's inertia, deceleration time and potential energy load. The higher a system's inertia is, the shorter the deceleration time is. Frequent braking requires braking resistors of larger power and smaller resistance.

Inverter Models	Recommended Braking Resistor Power	Recommended Braking Resistor Resistance	Braking Unit
AT550-S2-0R4GB	80W	$\geq 200\Omega$	Built-In (Standard)
AT550-S2-0R7GB	80W	$\geq 150\Omega$	
AT550-S2-1R5GB	100W	$\geq 100\Omega$	
AT550-S2-2R2GB	100W	$\geq 70\Omega$	
AT550-T3-0R7G/1R5PB	150W	$\geq 300\Omega$	
AT550-T3-1R5G/2R2PB	150W	$\geq 220\Omega$	
AT550-T3-2R2G/4R0PB	250W	$\geq 200\Omega$	
AT550-T3-4R0G/5R5PB	300W	$\geq 130\Omega$	
AT550-T3-5R5G/7R5PB	400W	$\geq 90\Omega$	
AT550-T3-7R5G/011PB	500W	$\geq 65\Omega$	
AT550-T3-011G/015PB	800W	$\geq 43\Omega$	
AT550-T3-015G/018PB	1.0kW	$\geq 32\Omega$	
AT550-T3-018G/022PB	1.3kW	$\geq 25\Omega$	
AT550-T3-022G/030PB	1.5kW	$\geq 22\Omega$	Built-In (optional)
AT550-T3-030G/037P	2.5kW	$\geq 16\Omega$	
AT550-T3-037G/045P	3.7 kW	$\geq 12.6\Omega$	
AT550-T3-045G/055P	4.5 kW	$\geq 9.4\Omega$	External
AT550-T3-055G/075P	5.5 kW	$\geq 9.4\Omega$	
AT550-T3-075G/090P	7.5 kW	$\geq 6.3\Omega$	
AT550-T3-090G/110P	4.5 kW $\times 2$	$\geq 9.4\Omega \times 2$	
AT550-T3-110G/132P	5.5 kW $\times 2$	$\geq 9.4\Omega \times 2$	
AT550-T3-132G/160P	6.5 kW $\times 2$	$\geq 6.3\Omega \times 2$	
AT550-T3-160G/200P	16 kW	$\geq 6.3\Omega \times 2$	
AT550-T3-200G/220P	20 kW	$\geq 2.5\Omega$	
AT550-T3-220G/250P	22 kW	$\geq 2.5\Omega$	External
AT550-T3-250G/280P	12.5 kW $\times 2$	$\geq 2.5\Omega \times 2$	
AT550-T3-280G/315P	14 kW $\times 2$	$\geq 2.5\Omega \times 2$	
AT550-T3-315G /355P	16 kW $\times 2$	$\geq 2.5\Omega \times 2$	
AT550-T3-355G /400P	17 kW $\times 2$	$\geq 2.5\Omega \times 2$	
AT550-T3-400G /450P	14 kW $\times 3$	$\geq 2.5\Omega \times 3$	
AT550-T3-450G	15 kW $\times 3$	$\geq 2.5\Omega \times 3$	

AT550-T3-500G	20 kW×4	≥2.5Ω×4	
AT550-T3-560G	25 kW×4	≥2.5Ω×4	
AT550-T3-630G	28 kW×4	≥2.5Ω×4	
AT550-T3-710G	32 kW×4	≥2.5Ω×4	

- " × 2" indicates that two braking units with each braking resistor are connected in parallel.
- " × 3" indicates the same as " × 2"

### 3.5 Selection of Expansion Card

Model	Supported Model	Name	Function Descriptions
A00E01	All	485 Communication Card	Expand RS485 Port, Support MODBUS Communication Protocol, Inverter as Slave
A00E02	All	OC Output PG Card	Correspond to 0C output encoder
A00E03	All	Differential Output PG Card	Correspond to differential output encoder
A00E05	All	I/O Expansion Card	Expand 5 digital inputs, support leakage and source pattern wiring methods, and support external power.
A00E08	All	Resolver PG Card	Resolver Expansion Card
A00E12	All	Injection Molding Machine Current Riser Card	Support proportional pressure and proportional data input 0-1A and 0-2A. Support touch screen's one-click parameters setting.
A00E13	All	485+3I Expansion Card	Expand RS485 port, support MODBUS Communication Protocol, inverter as slave, and expand 3 digital inputs
A00E15	All	485+Differential Output Expansion Card	Correspond to differential output encoders, and 485 communications.
A00E18	All	Double PT100 Motor Temperature Collecting Card	Collecting Motor's Temperature
A00E19	All	Rotary Encoder Expansion Card	Resolver Expansion Card
A00E20	All	485+3DI Expansion Card	Expand RS485 port, support MODBUS Communication Protocol, inverter as slave, and expand 3 digital inputs

### 3.6 Wiring Method

A typical wiring method of AT550 Series Inverter is shown below:

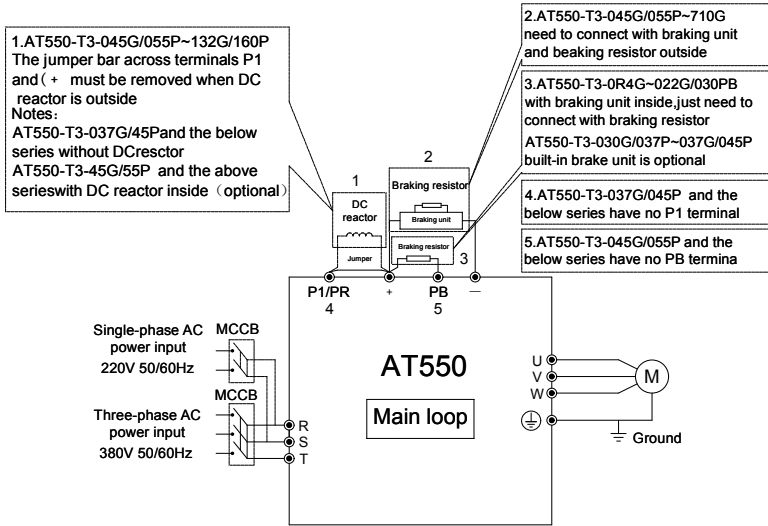

Figure 3.2 Inverter's Major Circuit Wiring Diagram

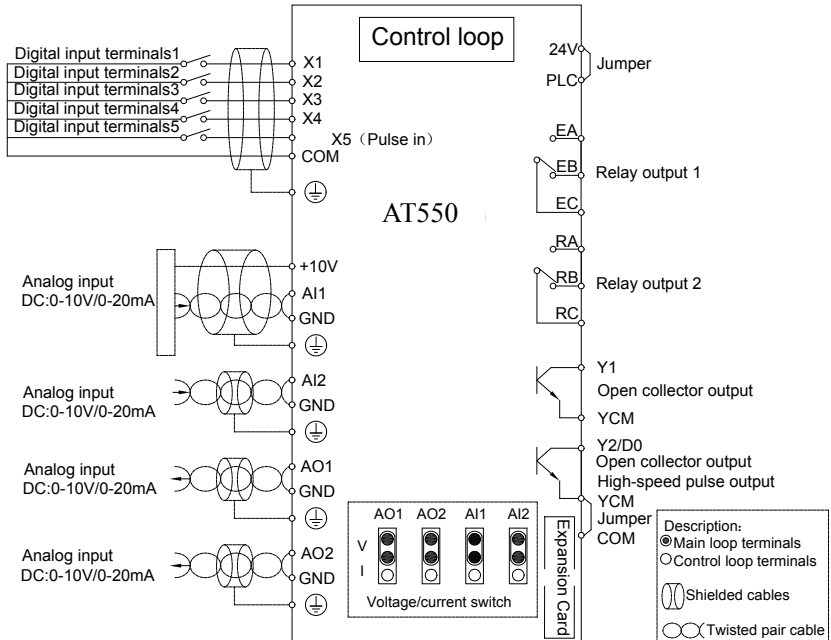

Figure 3.2 Inverter's Control Circuit Wiring Diagram

**Note:**

- 1) Terminal ●: Major Loop Terminals. Terminal ○: Control Circuit Terminals.
- 2) The product models with "B" indicates the braking units.
- 3) Choose the braking resistors based on users' needs. Refer to Selection of Braking Unit and Braking Resistor (P22-24).
- 4) Signal wires and power wires must be routed separately. If the control cables and power cables cross together, it is best to make them crossed as 90 degrees. The analog signal line is best to use shielded twisted pair; The power cable is best to use shielded three-core cable (its specifications are higher than the average motor cable's) or to follow the user manual.
- 5) R is the standard relay, the relay E is optional.

**3.6.1 Product Terminals and Wiring**

1) Single-Phase Inverter's Terminal Layout of Major Circuit and Size Description:

Symbol	Name	Function Descriptions
R、T	Single-Phase Power Supply Input Terminals	Connect to the single-phase 220V AC power supply
+、-	Positive and Negative Terminals of DC Bus	Common DC Bus Input Point
+、PB	Connecting Terminals of Braking Resistor	Connect to a braking resistor
U、V、W	Inverter Output Terminals	Connect to a three-phase motor
⊕	Ground Terminal	Must be grounded

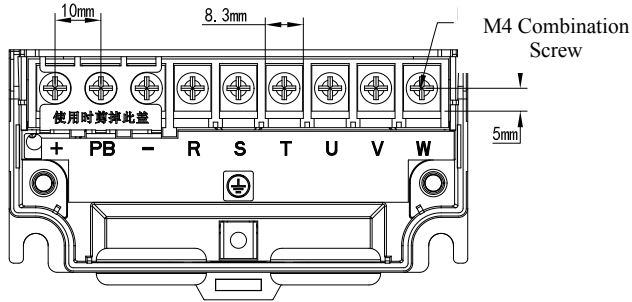

Figure 3.3 Single-Phase 0.75-2.2kW Inverter's Terminal Layout of Major Circuit and Size Diagram

Model	Rated Input Current A	Recommended Input Output Power Cable mm <sup>2</sup>	Recommended Solderless Terminal Models	Recommended Ground Cable mm <sup>2</sup>	Recommended Solderless Terminal Models
AT550-S2-0R4GB	5.4	0.75	SNB1.25-4S	0.75	SNB1.25-4S
AT550-S2-0R7GB	8.2	0.75	SNB1.25-4S	0.75	SNB1.25-4S
AT550-S2-1R5GB	14	1.5	SNB2-4S	1.5	SNB2-4S
AT550-S2-2R2GB	23	2.5	SNB2-4S	2.5	SNB2-4S

2) Three-Phase Inverter's Terminal Layout of Major Circuit and Size Description:

Symbol	Name	Function Descriptions
R、S、T	Three-Phase Power Supply Input Terminals	Connect to the three-phase AC power supply
+、-	Positive and Negative Terminals of DC Bus	Common DC Bus Input point Connect the external braking units to the inverters of 45 kW and above
+、PB	Connecting Terminals of Braking Resistors	Connect the braking resistors to the inverters of 37 kW and below



P1/PR、+	Connecting Terminals of External Reactor	Connect to an external reactor
U、V、W	Inverter Output Terminals	Connect to a three-phase motor
⊕	Ground Terminal	Must be grounded

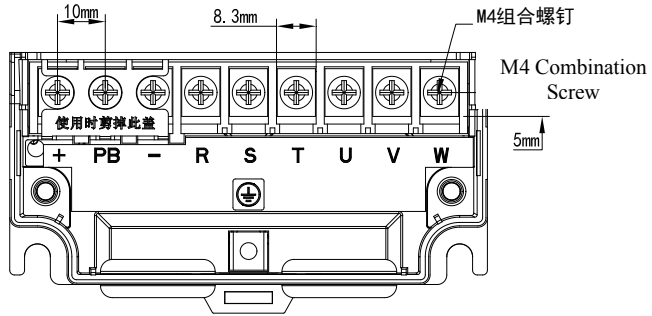

Figure 3.4 Three-Phase 0.75-2.2kW Inverter's Terminal Layout of Major Circuit and Size Diagram

Model	Rated Input Current A	Recommended Input Output Power Cable mm <sup>2</sup>	Recommended Solderless Terminal Models	Recommended Ground Cable mm <sup>2</sup>	Recommended Solderless Terminal Models
AT550-T3-0R75G/1R5PB	3.4	0.75	SNB1.25-4S	0.75	SNB1.25-4S
AT550-T3-1R5G/2R2PB	5	0.75	SNB1.25-4S	0.75	SNB1.25-4S
AT550-T3-2R2G/4R0PB	5.8	0.75	SNB1.25-4S	0.75	SNB1.25-4S

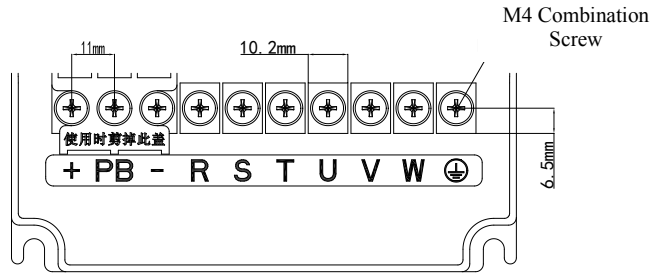

Figure 3.5 Three-Phase 4.0-5.5kW Inverter's Terminal Layout of Major Circuit and Size Diagram

Model	Rated Input Current A	Recommended Input Output Power Cable mm <sup>2</sup>	Recommended Solderless Terminal Models	Recommended Ground Cable mm <sup>2</sup>	Recommended Solderless Terminal Models
AT550-T3-4R5G/5R5PB	10.5	1.5	SNB2-4S	1.5	SNB2-4S
AT550-T3-5R5G/7R5PB	14.6	2.5	SNB2-4S	2.5	SNB2-4S

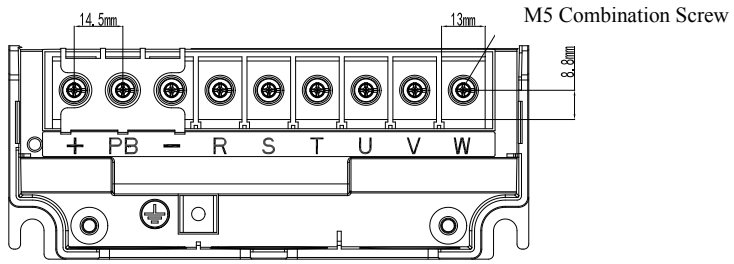

Figure 3.6 Three-Phase 7.5-11kW Inverter’s Terminal Layout of Major Circuit and Size Diagram

Model	Rated Input Current A	Recommended Input Output Power Cable mm <sup>2</sup>	Recommended Solderless Terminal Models	Recommended Ground Cable mm <sup>2</sup>	Recommended Solderless Terminal Models
AT550-T3-7R5G/011PB	20.5	4.0	SNB3.5-5	4.0	SNB3.5-5
AT550-T3-011G/015PB	26	4.0	SNB3.5-5	4.0	SNB3.5-5

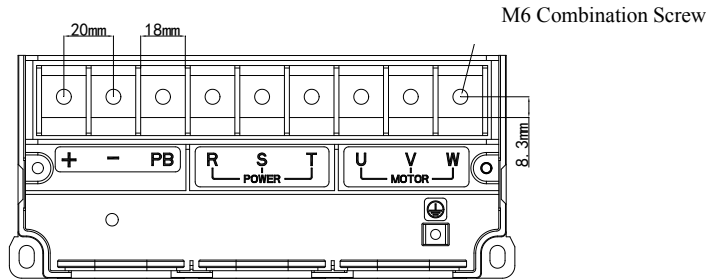

Figure 3.7 Three-Phase 15-22kW Inverter’s Terminal Layout of Major Circuit and Size Diagram

Model	Rated Input Current A	Recommended Input Output Power Cable mm <sup>2</sup>	Recommended Solderless Terminal Models	Recommended Ground Cable mm <sup>2</sup>	Recommended Solderless Terminal Models
AT550-T3-015G/018PB	35	6.0	SNB5.5-6S	6.0	6.0
AT550-T3-018G/022PB	38.5	10	SNB8-6	10	10
AT550-T3-022G/030PB	46.5	10	SNB8-6	10	10

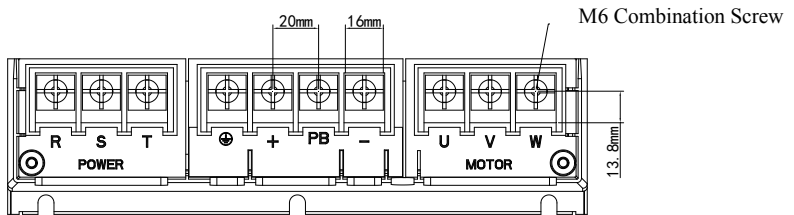

Figure 3.8 Three-Phase 30-37kW Inverter’s Terminal Layout of Major Circuit and Size Diagram

Model	Rated Input Current A	Recommended Input Output Power Cable mm <sup>2</sup>	Recommended Solderless Terminal Models	Recommended Ground Cable mm <sup>2</sup>	Recommended Solderless Terminal Models
AT550-T3-030G/037P	62	16	SNB14-6	16	SNB14-6
AT550-T3-037G/045P	76	25	SNB22-8	16	SNB14-6

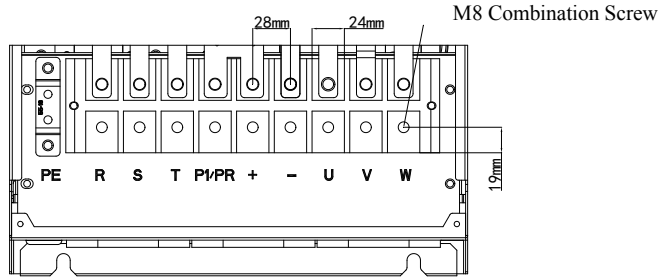

Figure 3.9 Three-Phase 45-55kW Inverter’s Terminal Layout of Major Circuit and Size Diagram

Model	Rated Input Current A	Recommended Input Output Power Cable mm <sup>2</sup>	Recommended Solderless Terminal Models	Recommended Ground Cable mm <sup>2</sup>	Recommended Solderless Terminal Models
AT550-T3-045G/055P	92	35	RNB38-8S	16	SNB14-6
AT550-T3-055G/075P	113	50	RNB38-8S	25	SNB22-6

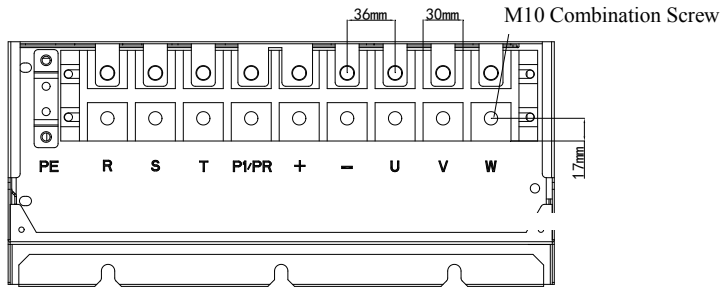

Figure 3.10 Three-Phase 75-90kW Inverter’s Terminal Layout of Major Circuit and Size Diagram

Model	Rated Input Current A	Recommended Input Output Power Cable mm <sup>2</sup>	Recommended Solderless Terminal Models	Recommended Ground Cable mm <sup>2</sup>	Recommended Solderless Terminal Models
AT550-T3-075G/090P	157	70	RNB60-10	35	RNB38-10S
AT550-T3-090G/110P	180	95	RNB80-10	50	RNB38-10S

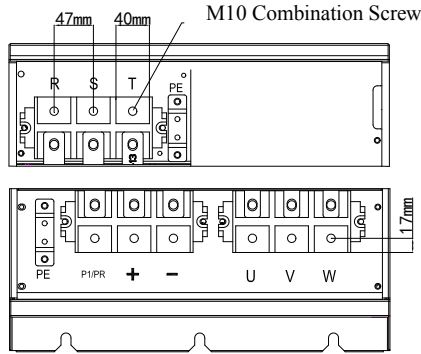

Figure 3.11 Three-Phase 110-132kW Inverter’s Terminal Layout of Major Circuit and Size Diagram

Model	Rated Input Current A	Recommended Input Output Power Cable mm <sup>2</sup>	Recommended Solderless Terminal Models	Recommended Ground Cable mm <sup>2</sup>	Recommended Solderless Terminal Models
AT550-T3-110G/132P	214	120	DT120-10	70	RNB60-10
AT550-T3-132G/160P	256	150	DT150-10	70	RNB60-10

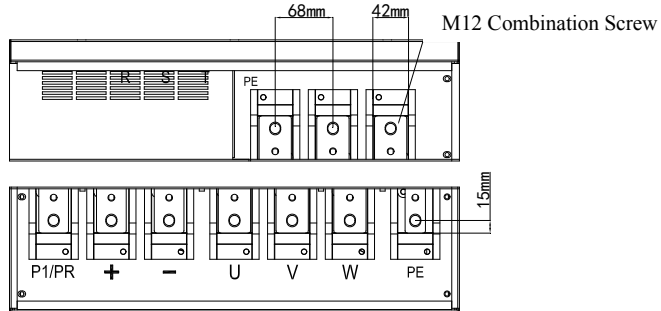

Figure 3.12 Three-Phase 160-200kW Inverter’s Terminal Layout of Major Circuit and Size Diagram

Model	Rated Input Current A	Recommended Input Output Power Cable mm <sup>2</sup>	Recommended Solderless Terminal Models	Recommended Ground Cable mm <sup>2</sup>	Recommended Solderless Terminal Models
AT550-T3-160G/185P	307	185	DT185-12	95	RNB80-12
AT550-T3-200G/220P	385	2*120	DT240-12	120	DT120-12

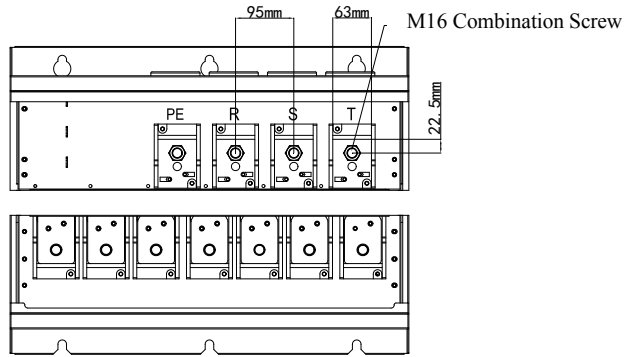

Figure 3.13 Three-Phase 220-280kW Inverter's Terminal Layout of Major Circuit and Size Diagram

Model	Rated Input Current A	Recommended Input Output Power Cable mm <sup>2</sup>	Recommended Solderless Terminal Models	Recommended Ground Cable mm <sup>2</sup>	Recommended Solderless Terminal Models
AT550-T3-220G/250P	430	2*120	DT240-16	120	DT120-16
AT550-T3-250G/280P	468	2*120	DT240-16	120	DT120-16
AT550-T3-280G/315P	525	2*150	DT300-16	150	DT150-16

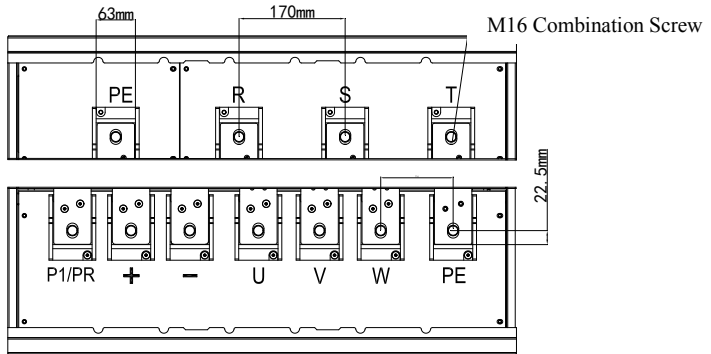

Figure 3.14 Three-Phase 315-450kW Inverter's Terminal Layout of Major Circuit and Size Diagram

Model	Rated Input Current A	Recommended Input Output Power Cable mm <sup>2</sup>	Recommended Solderless Terminal Models	Recommended Ground Cable mm <sup>2</sup>	Recommended Solderless Terminal Models
AT550-T3-315G/355P	590	2*150	DT300-16	150	DT150-16
AT550-T3-355G/400P	665	2*185	DT400-16	185	DT185-16
AT550-T3-400G	785	2*200	DT400-16	200	DT200-16
AT550-T3-450G	883	2*300	2*DT300-16	300	DT300-16

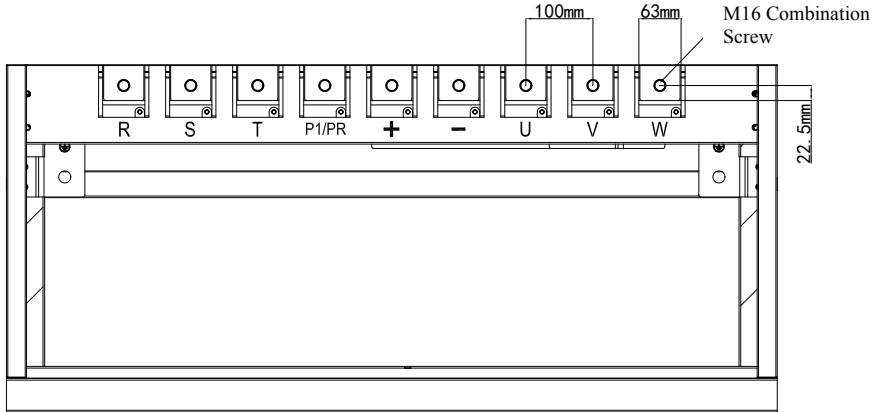

Figure 3.15 Three-Phase 500-560kW Inverter’s Terminal Layout of Major Circuit and Size Diagram

Model	Rated Input Current A	Recommended Input Output Power Cable mm <sup>2</sup>	Recommended Solderless Terminal Models	Recommended Ground Cable mm <sup>2</sup>	Recommended Solderless Terminal Models
AT550-T3-500G	900	2*300	2*DT300-16	300	DT300-16
AT550-T3-560G	1020	2*300	2*DT300-16	300	DT300-16

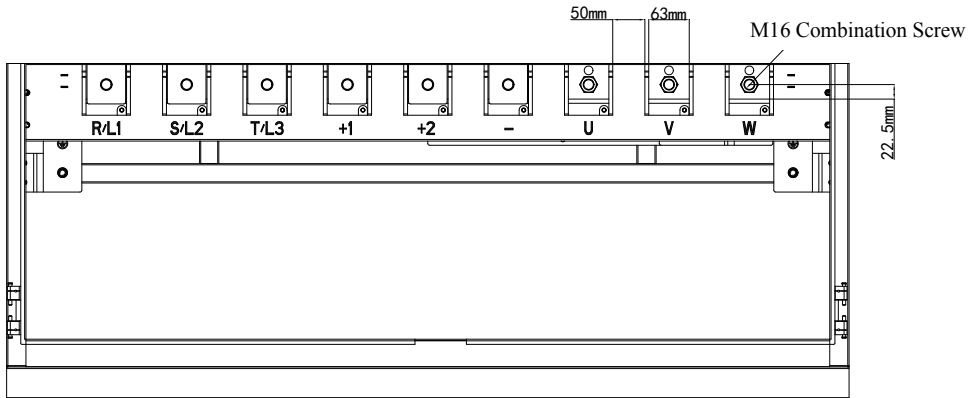

Figure 3.16 Three-Phase 630-710kW Inverter’s Terminal Layout of Major Circuit and Size Diagram

Model	Rated Input Current A	Recommended Input Output Power Cable mm <sup>2</sup>	Recommended Solderless Terminal Models	Recommended Ground Cable mm <sup>2</sup>	Recommended Solderless Terminal Models
AT550-T3-630G	1120	2*300	2*DT300-16	300	DT300-16
AT550-T3-710G	1260	2*300	2*DT300-16	300	DT300-16

Note: In the lists above, 2\*120 represents 2 cables of 120mm<sup>2</sup>;

All the recommended solderless terminals above are manufactured by Shenzhen Goldsite (RNB series and DT Series Solderless Terminals)

## Precautions on Wiring

### a) Power Input Terminals L1, L2 or R, S, T

No Phase Sequence Requirements.

### b) DC Bus Terminals (+), (-)

- Terminals (+) and (-) of DC bus still have remaining charge with hazardous voltages after the inverter is switched off. After the indicator “CHARGE” goes off, wait at least 10 minutes before touching the inverter. Otherwise, you might get electric shock.
- Be sure to connect the external braking components to the corresponding terminals(+) and (-). Otherwise it could cause a fire.
- The cable length of the braking units shall be no longer than 10m. Use twisted-pair cables or pair wires for parallel connection.
- Do not connect the braking resistors directly to the DC bus. Otherwise, it may damage the inverter and even cause a fire.

### c) Connecting Terminals of Braking Resistor (+), PB

- The connecting terminals of the braking resistor are effective only for the inverters of 37kW or below with a built-in braking unit.
- The cable length of the braking resistor shall be less than 5 m. Otherwise, it may damage the inverter.

### d) Connecting Terminals of External Reactor P1/PR, ( + )

- For the inverter of 45 kW and above, remove the jumper bar across terminals P1 /PR and (+) and install the reactor between the two terminals.

### e) Output Terminals of Inverter: U, V, W

- The specification and installation method of external power cables must comply with the local safety regulations and IEC standards.
- The capacitor or surge absorber must not be connected to the output side of the inverter. Otherwise, it may cause frequent errors or even damage the inverter.
- If the motor cable is too long, electrical resonance will be generated due to the impact of distributed capacitance. This will damage the motor insulation or generate higher leakage current, causing over current protection on the inverter. If the motor cable is greater than 100 m long, an AC output reactor must be installed close to the inverter.

### f) Terminal PE:

- This terminal must be properly grounded. Otherwise, it may cause electric shock, malfunction or even damage to the inverter.
- Do not connect the ground terminal to the neutral terminal of the power supply.

### 3.6.2 Control Terminals and Wiring

1) Terminal Arrangement of Control Circuit:

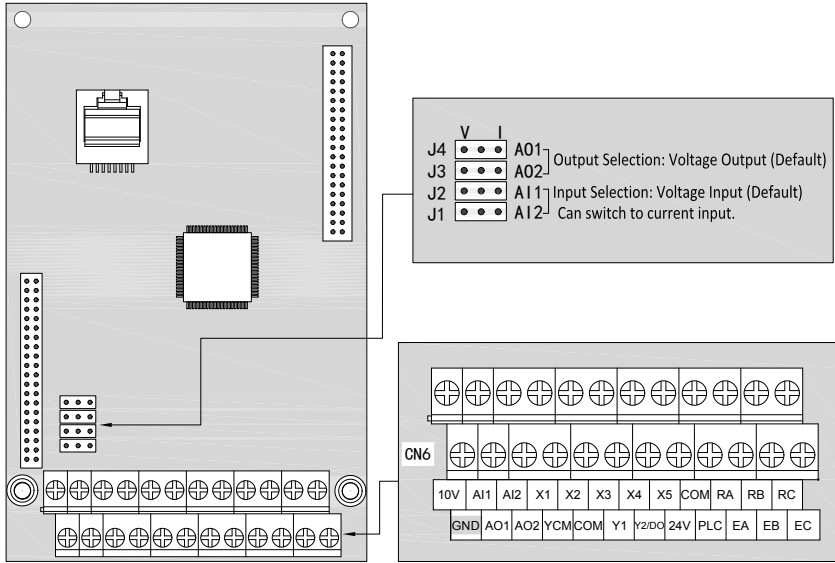

3.17 Control Circuit Terminals Layout

2) Description of Control Circuit Terminals:

Type	Terminal	Name	Function Description
Power supply	+10V-GND	External +10 V power supply	Provide +10 V power supply to external unit. Generally, it provides power supply to external potentiometer with resistance range of 1–5 kΩ. Maximum output current: 10 mA
	24V-COM	External +24V power supply	Provide +24 V power supply to external unit. Generally, it provides power supply to input and output terminals and external sensors. Maximum output current: 200 mA
	PLC	External power input terminal	X input terminal of the power connector, the factory default control panel 24V with short, if you need an external 24V power supply, you need to jumper terminals on the control panel to remove the external 24V power to the PLC terminal
Power supply	YCM	Yn output common terminal	Y1, Y2 two output terminals can be individually grounded, and control panel factory default COM shorted to ground alone if necessary, the need to control board jumpers removed, the terminal will be connected to the YCM



Type	Terminal	Name	Function Description
Analog input	AI1-GND	Analog input terminal 1	1、 Input voltage range:DC 0V~10V 2、 Input impedance :22kΩ
	AI2-GND	Analog input terminal 2	1、 Input range: DC 0V ~10V /0mA ~20mA, decided by the AI2 jumper on the control board. 2、 Input impedance: 22 kΩ (voltage input), 500 Ω (current input)
Digital input	X1-COM	Digital input1	1、 Optical coupling isolation, compatible with dual polarity input 2、 Impedance: 2.4 kΩ 3、 Voltage range for level input: 9–30 V
	X2-COM	Digital input2	
	X3-COM	Digital input3	
	X4-COM	Digital input4	
	X5-COM	High-speed pulse input terminal	Besides features of X1 - X4, it can be used for high-speed pulse input. Maximum input frequency: 100 kHz
Analog output	AO1-GND	Analog output 1	Voltage or current output is decided by jumper AO1. Output voltage range: 0–10 V Output current range: 0–20 mA
	AO2-GND	Analog output 2	Output range:0V~10V/0mA~20mA Using the AO2 jumper on the left side of the control board to determine the voltage or current output.
Digital output	Y1-YCM	Digital output 1	Optical coupling isolation, dual polarity open collector output Output voltage range: 0–24 V Output current range: 0–50 mA Note that YCM and COM are internally insulated, but they are shorted by jumper externally.
	Y2-YCM	High-speed pulse output terminal	It is limited by F3.00 As high-speed pulse output, the maximum frequency hits 100 kHz. As open-collector output, it specification is the same as that of Y1
Relay output	R/B-R/C	R relay normally closed terminal	Contact actuation capability: AC250V, 3A, COSφ=0.4. Relay E matching
	R/A-R/C	R relay normally open terminal	
Relay output	E/B-E/C	E relay normally closed terminal	Contact actuation capability: AC250V, 3A, COSφ=0.4. Relay E matching
	E/A-E/C	E relay normally open terminal	

Table 3.20 Description of Control Circuit Terminals

3) Wiring of Control Circuit Terminals

a) AI Terminals: Weak analog voltage signals are easily interfered, and therefore the shielded cable must be used and the cable length must be less than 20 m, as shown in following figure.

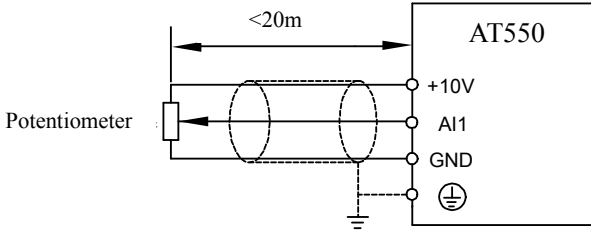

Figure 3.18 Diagram of AI Terminals

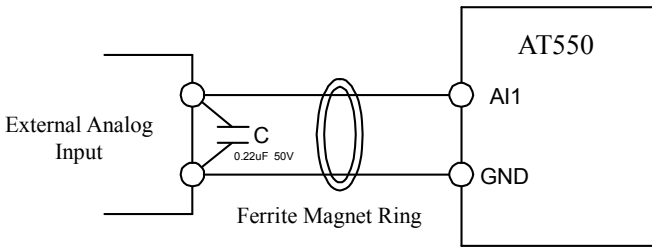

Figure 3.19 Wiring of AI Terminals

b) Wiring of DI terminals

Generally, select a shielded cable that is no longer than 20 m. When active drive is adopted, it is necessary to apply filtering in order to prevent the interference to the power supply. It is recommended to use the contact control mode.

SINK Wiring

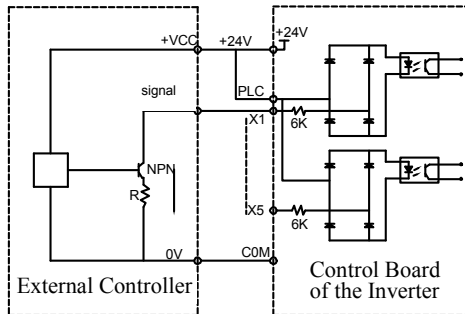

Figure 3.20 Wiring in SINK Mode

This is one of the most commonly used connection mode. If you use an external power supply, you must remove the jumper bar between +24V and PLC. Anode of the external power needs to be connected to PLC terminal, and cathode needs to be connected to COM terminal.

c) SOURCE Wiring

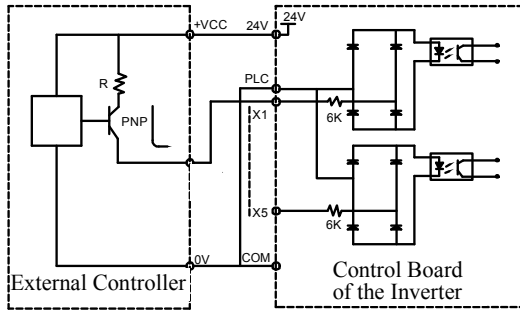

Figure 3.21 Wiring in SOURCE Mode

This wiring must jump the jumper J12 of PLC to COM, and Connect the + 24V and the COM terminal of the external controller together. If you use an external power supply, the cathode of the power supply must be connected to PLC.

d) Wiring of DO Terminal

When the digital output terminals need to drive the relay, an absorption diode shall be installed around the relay coil. Otherwise, it may cause damage to the 24V DC power supply.

Note: The polarity of the absorption diode must be installed properly. As shown in Figure 3.9, failure to comply will lead to burning the 24V DC power supply whenever the digital output terminal is active.

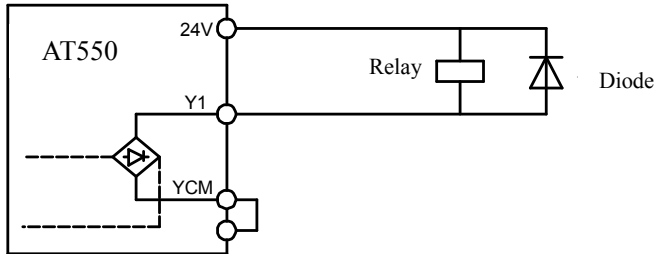

Figure 3.22 DO Terminal Wiring Diagram

**3.7 Major Circuit Terminals Screw Specs and Tightening Torque Standard**

Inverter Powers	Terminal Specs	Screw Specs	Torque Standard
0.75-2.2kW	BA5-09-10.0-06	M4	2N.m
4.0-5.5kW	BA5-10-11.0-09	M4	2N.m
7.5-11kW	BA8-09-14.5-01-C	M5	4N.m
15-22kW	BA20-09-20.0-01	M6	8N.m
30-37kW	BA20-03-20.0-01	M6	8N.m
45-55kW	DRTB50-NR-09-CNNT	M8	20N.m
75-90kW	DRTB100-RHC-09-CNNT	M10	35N.m
110-132kW	RD300-01 600V 300A	M10	35N.m
160-200kW	SET420-B(Nut included)	M12	60N.m
220-280kW	SET630(Nut included)	M16	130N.m
315-710kW	SET630(Nut included)	M16	130N.m

# Chapter 4 Keyboard and Display

## 4.1 Operation and Display Interface

Through the operation panel, user may perform such operations such as modifying the function parameters, monitoring the status of inverter, and controlling the operation of inverter (start and stop). Its appearance and function area are shown below:

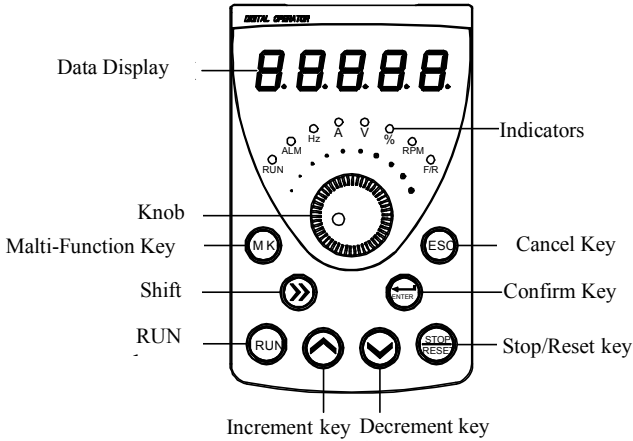

Figure 4.1 Keyboard Layout

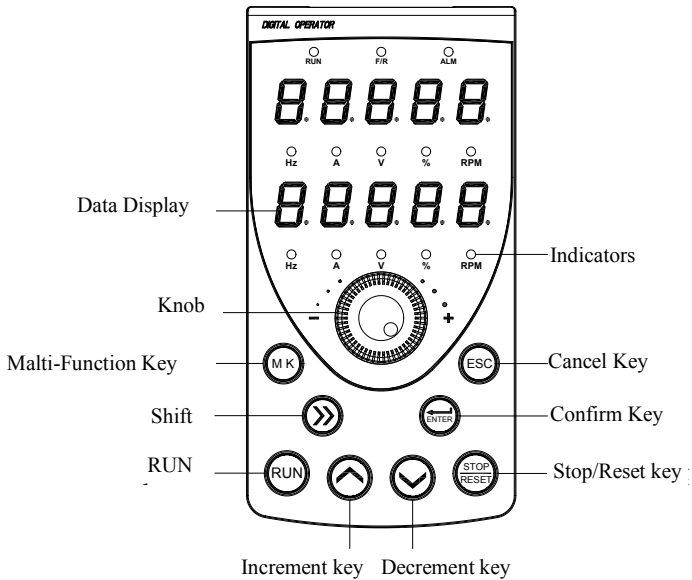

Figure 4.2 Double Display Keyboard Layout

### 4.2 Keyboard Indicators Description

- RUN: ON indicates that the inverter is in the Operating state, and OFF indicates that it is in the stop state;
- ALM: Malfunction Indicator. When an error occurs, the indicator turns on. Normally it is off;
- Hz : Unit of frequency, ON indicates the corresponding parameter values of the units;
- A : Unit of current;
- V :Unit of voltage;
- % : Percentage;
- Rpm: Revolutions Per Minute;
- F/R: Forward/Reverse.

### 4.3 Keyboard Button Description

Button	Name	Function
ESC	Escape key	Enter the primary menu or exit
ENTER	Confirm Key	Enter the next interface; Confirm the setting of parameters
∧	Increment key	Increase the parameter number or function code by one unit
∨	Decrement key	Decrease the parameter number or function code by one unit
>>	Shift Key	Select the displayed parameters in turn in the stop or Operating state, and shift through each unit when changing the parameters.
RUN	RUN key	Start the inverter.
STOP/RESET	Stop / Reset key	Stop the inverter when it is in the Operating state and reset the inverter when it is in the fault state.
MK	Multi-Function Key	Switch functions according to F8.01

Table 4.1 Keyboard Functions Table

### 4.4 Viewing and Modifying Function Codes

The operation panel of AT550 series features three-level menu mode: function parameters group (first level of menu), function codes (second level of menu), and function codes modification (third level of menu). The float chart is shown as below:

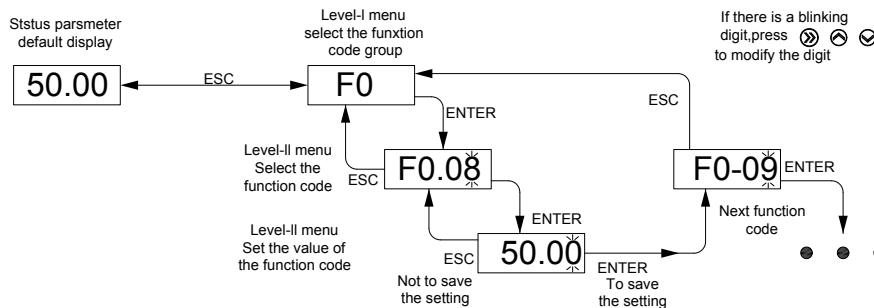

Figure 4.3 Three-Level Menu Float Chart of Operation Procedure

When changing parameters on the third level menu, you can press “ESC” or “ENTER” to return to the second menu. The difference is that pressing “ENTER” saves the modified parameters while pressing “ESC” does not save them.

For example: the function code F2.03 changed from 12 set to 22.

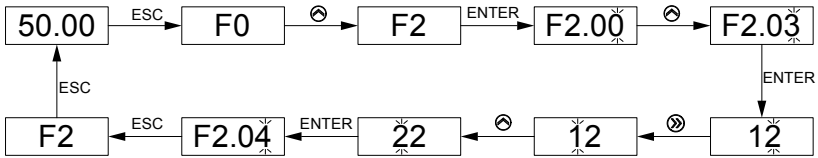

Figure 4.4 Example of Changing the Parameter Value

### 4.5 Selecting Menu Mode

AT550 series inverter offers three menu modes to select from. User may set the corresponding bit of the menu mode he/she needs as "1" according to F0.25 and switch using the button "MK". Follow figure 3-4 to switch the menus after setting the function parameters.

Note: Only when F8.01 is set to 1, "MK" button selects menu modes.

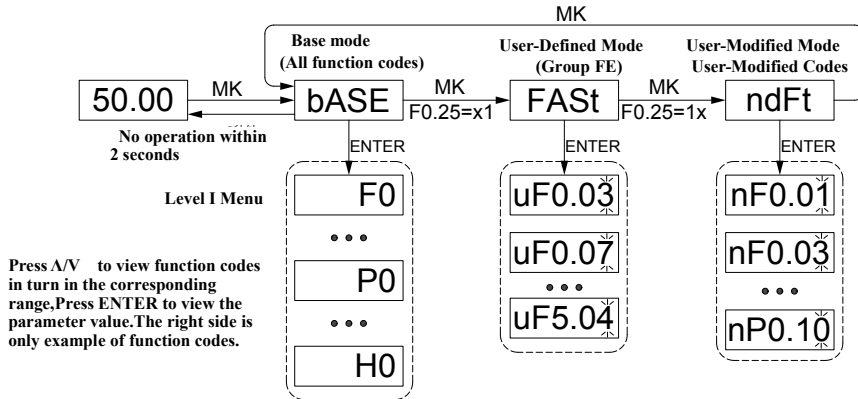

Figure 4.5 Menu Switching

# Chapter 5 Basic Operation and Test Run

## 5.1 Quick Adjustment Guidance

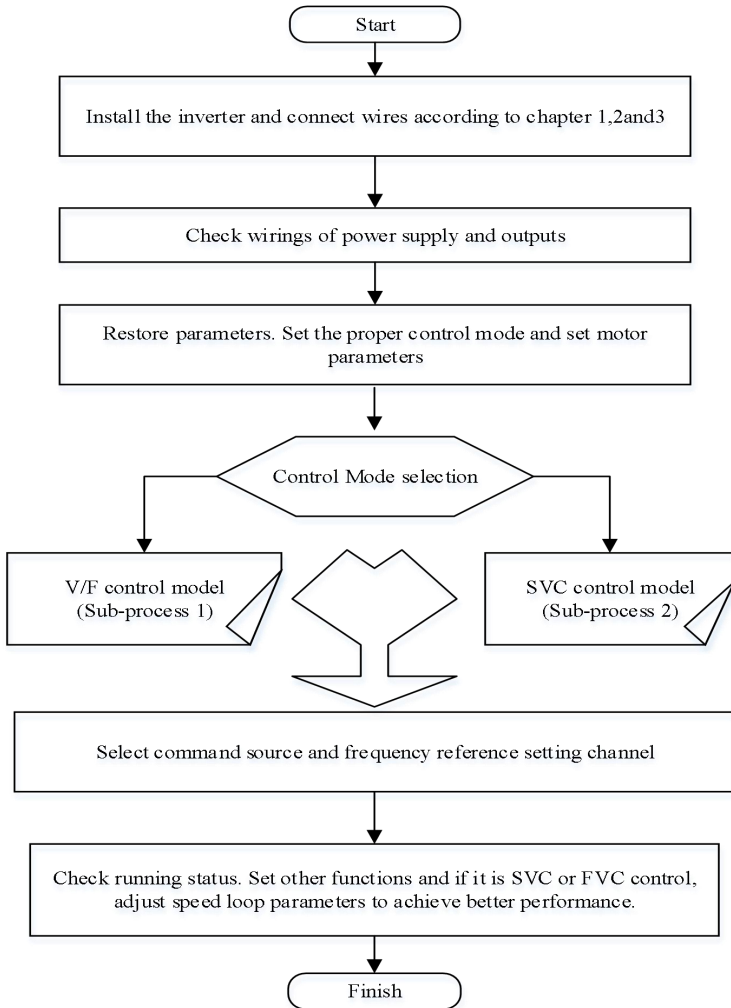

Figure 5.1 Quick Adjustment Procedure

## 5.2 Precautions Before Power-On

Please execute the following steps before power-on.

Items	Contents
Check the power voltage	Make sure the power voltage is correct
	Properly connect the input terminals (R/S/T) of power supply
	Correctly ground inverter and motor
Check the connection between the output terminals of inverter and the motor terminals	Make sure the output terminals(U/V/W) is firmly connected to the motor terminals
Check the connection on inverter's control circuit terminals.	Please confirm if the control circuit terminals are firmly connected to other control devices.
Check the status of inverter's control circuit terminals.	Make sure all of the terminals are OFF (Inverter is in an inactive mode)
Load Check	Make sure the motor is in no-load status and unconnected to mechanical system

## 5.3 Display Status After Power-On

After power-on, the display on the operation panel in normal status is shown as below:

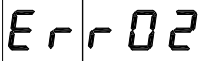
Status	Display	Description
Normal		Default Display of Digital Setting of 50Hz
Faulty		Inverter stops working when an error occur and displays the error type

## 5.4 Motor Control Methods Selection

### 5.4.1 Selection References of Motor Control Methods

Parameters	Description	Application
Motor Control Mode (F0.01)	0: Sensorless Vector Control (SVC)	It indicates open-loop vector control, and is applicable to high-performance control applications such as machine tool, centrifuge, wire drawing machine and injection moulding machine. One inverter can operate only one motor.
	1: Flux Vector Control (FVC)	It refers to closed-loop vector control. It is applicable to high-accuracy speed control or torque control applications such as high-speed paper making machine, crane and elevator. One inverter can operate only one motor. An encoder must be installed at the motor side, and a PG card matching the encoder must be installed at the inverter side.
	2: Voltage/Frequency (V/F) control (Open-Loop Control)	It is applicable to applications with low load requirements or applications where one inverter operates multiple motors, such as a fan and a pump.



5.4.2 Control and Adjustment Flow Chart of V/f and SVC

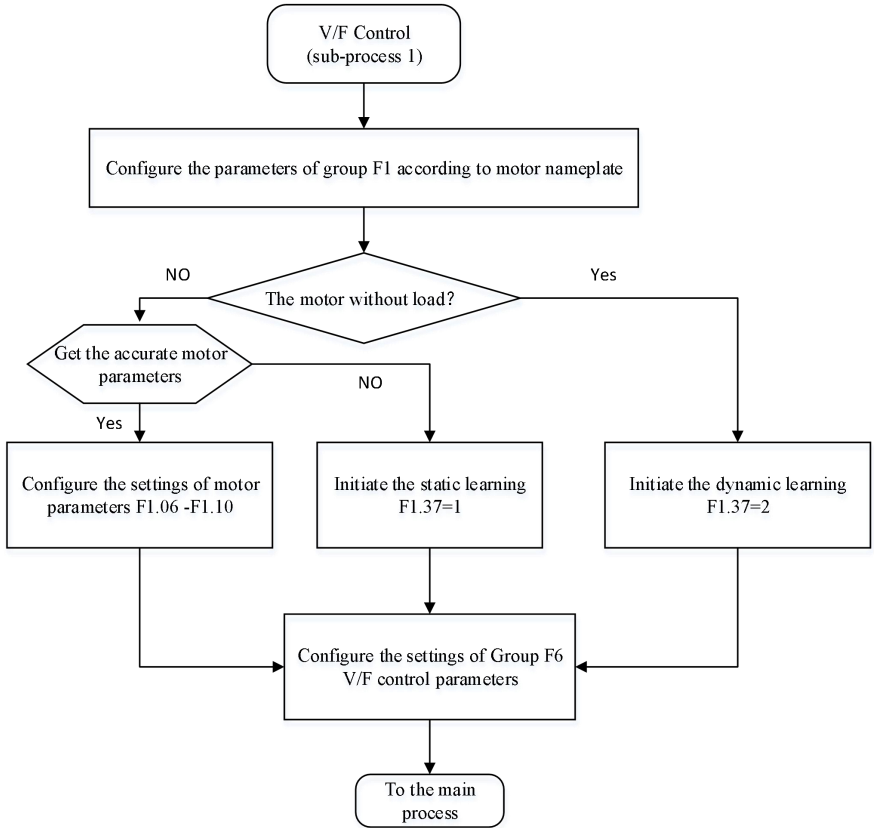

Figure 5.2 Inverter's Adjustment Sub-Process Flow (V/f Control)

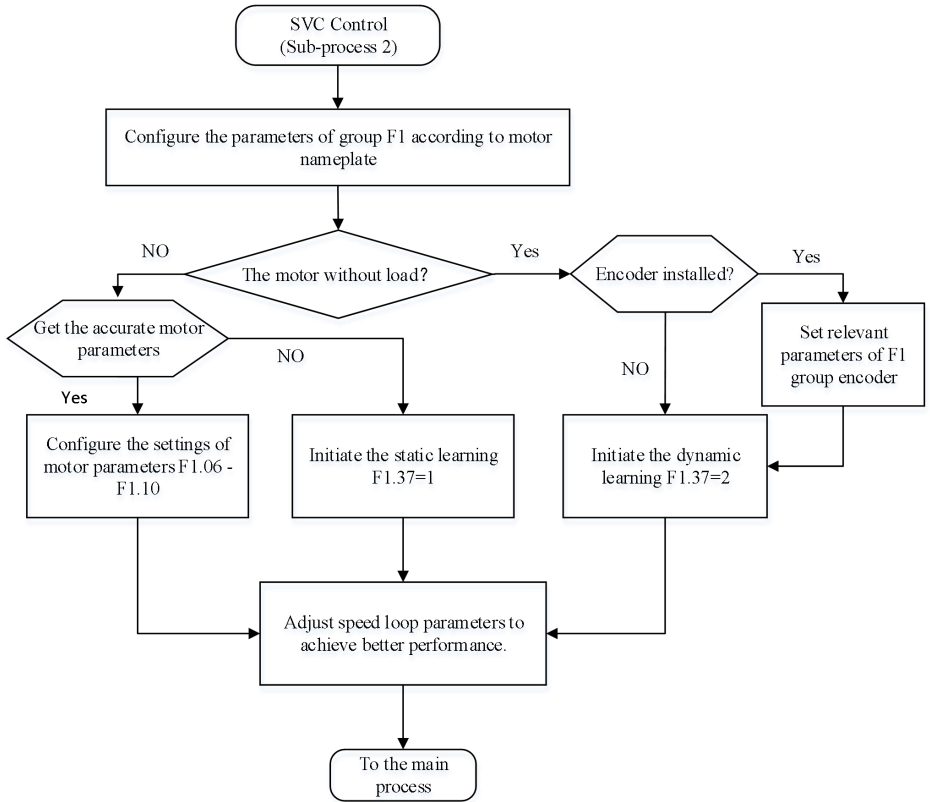

Figure 5.3 Inverter's Adjustment Sub-Process Flow (Vector Control)

### 5.5 Initialization of Parameters

Restore all of settings to default values. After the initialization, F0.24 is automatically set to 0.

F0.24	Restore Default Settings	Range: 0~501	Default: 0
-------	--------------------------	--------------	------------

1: Restore default settings except motor parameters

If F0.24 is set to 1, most function codes are restored to the default settings except motor parameters, frequency reference resolution, errors records, accumulated operating time, accumulated power-on time and accumulated power consumption .

2: Clear records

If F0.24 is set to 2, the fault records, accumulated running time , accumulated power-on time and accumulated power consumption are cleared.

### 5.6 Operation Commands Source Selection

F0.02	Command Source Options	Range: 0~2	Default: 0
-------	------------------------	------------	------------

0: Operation panel control

Commands are given by pressing keys “RUN,STOP”on the operation panel.

1: Terminal control

Commands are given by means of multifunctional input terminals with functions such as “FWD, REV, JOGF, and JOGR”.

2: Communication control

Commands are given from the host computer.

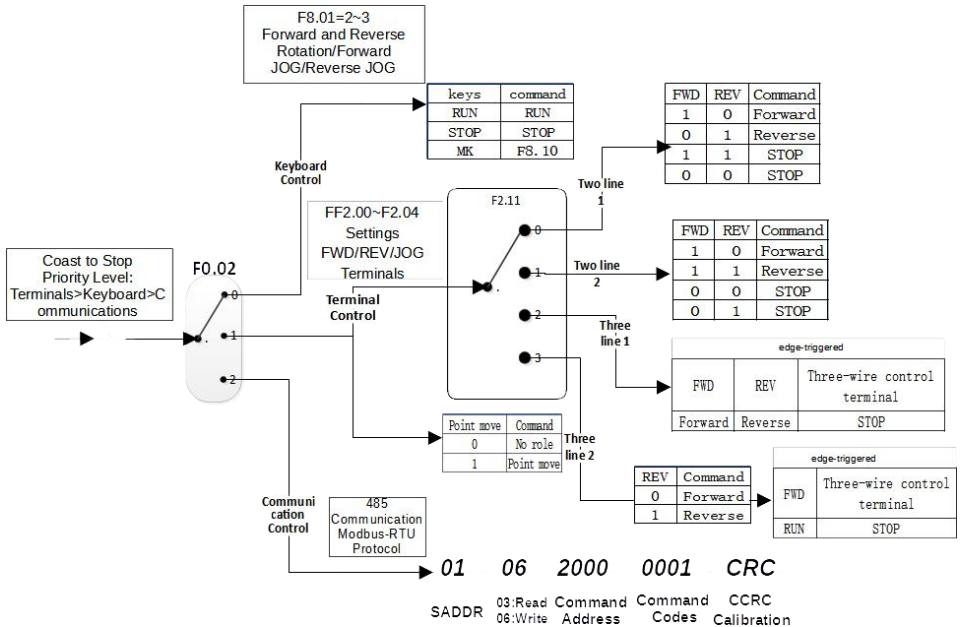

Figure 5.4 Operation Commands Source Selection

### 5.7 Frequency Source Selection

F0.03	Main Frequency(X) Source Selection	Range:0~13	Default:4
-------	------------------------------------	------------	-----------

0: Digital setting (No saving at power failure)

The initial value of the set frequency is the value of F0.08 (Preset frequency). You can change the set frequency by pressing  $\Delta$ 、V on the operation panel (or using the UP/DOWN function of input terminals).When the inverter is powered on again after power failure, the set frequency reverts to the value of F0.08.

1: Digital setting (save at power failure)

Basic operations are same as "0: Digital setting".

The only difference is that when the inverter is powered on again after power failure, the set frequency is the value memorized at the moment that power goes out.

Note: The hidden parameters set down by F0.20 cleared or unclear 0, factory default is cleared down.

2: AI1 (0~10 V voltage input)

3: AI2 (0~10 V voltage input or 4~20 mA current input, determined by jumper )

4: AI3 (0~10 V voltage input)

The frequency is set by analog input.

5: Pulse setting (X5)

The frequency is set by X5 (high-speed pulse). The signal specification of pulse setting is 9~30 V (voltage range) and 0~100 kHz (frequency range). The corresponding value 100% of pulse setting corresponds to the value of F0.10 (Maximum frequency).

6: Multi-command

In multi-command mode, combinations of different terminal X statuses correspond to different set frequencies. The AT550 supports a maximum of 16 speeds implemented by 16 state combinations of four X terminals (allocated with functions 12 to 15)in Group FC. The multiple references indicate percentages of the value of F0.10(Maximum frequency).

If a terminal X is used for the multi-command function, you will have to adjust settings in group F2, referring to the function explanations for group F2.

7: Simple PLC

When the simple programmable logic controller (PLC) mode is set as the frequency source, the operating frequency of the inverter can be switched over among the 16 frequency references. You can set the holding time and acceleration/deceleration time of the 16 frequency references. For more details, refer to the descriptions of Group FC.

8: PID

The output of PID control is used as the operating frequency. PID control is generally used in on-site closed-loop control, such as constant pressure closed-loop control and constant tension closed-loop control. When applying PID as the frequency source, you need to set parameters of PID function in group FA.

9: Communication setting

The frequency is set by the means of communication. In other conditions, data is given by the host computer through the communication address 0x1000. The data format is -100.00% to 100.00%. 100.00% corresponds to the value of maximum frequency in F0.10.

10:AI1+AI2

11:AI1-AI2

12:max(AI1,AI2)

13:min(AI1,AI2)

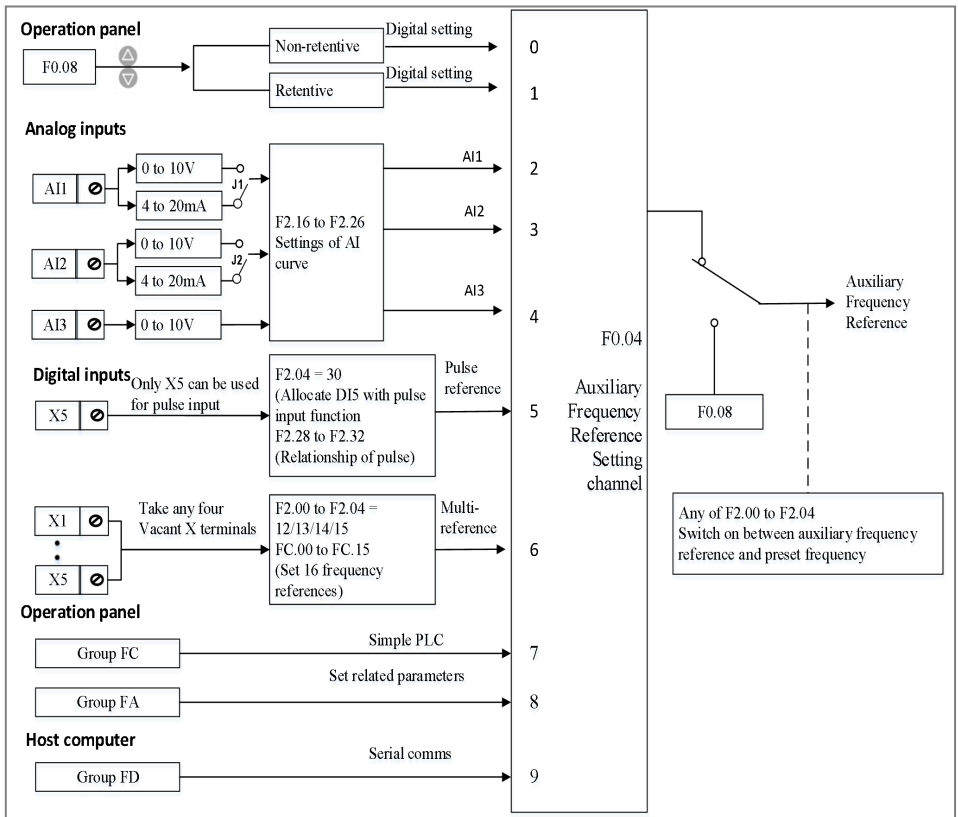

Figure 5.5 Frequency Source Selection

## 5.8 Stop Modes Selection

F7.10	Stop Modes	Range:0~1	Default:0
-------	------------	-----------	-----------

0: Decelerate to Stop

After the stop command is enabled, the inverter decreases the output frequency according to the deceleration time and stops when the frequency decreases to zero.

1: Coast to Stop

After the stop command is enabled, the inverter immediately stops the output. The motor will coast to stop due to the mechanical inertia.

## 5.9 Observation of Operation Status via DO and AO

### 5.9.1 Digital Output DO

AT550 series inverter comes standard with two digital output terminal Y1, Y2 (Y2 which can be used as high-speed pulse output DO), 2 relay outputs R, E, 2 analog outputs AO1, AO2 (can be selected as the current output).

F3.00	Y2/DO Terminal Output Mode	Range:0~1	Default:1
-------	----------------------------	-----------	-----------

Y2 / DO terminal is re-programmable terminals and can be used as high-speed pulse output terminal (DO). It also can be used as an open-collector terminal (Y2) of digital output.

0: Pulse Output (FMP)

1: Switch Signal Output (FMR)

When DO is set as a pulse output, the maximum frequency of the output pulse is 100kHz. To see more DO-related functions, please refer to Note F3.06.

F3.01	Y1 Output Function Selection	Range:0~45	Default:1
F3.02	Y2 Output Function Selection	Range:0~45	Default:0
F3.03	Relay R Output Function Selection	Range:0~45	Default:2
F3.04	Relay E Output Function Selection	Range:0~45	Default:0

Defined digital output terminal Y1, Y2 and relay R, E functions. When Y2/DO terminal is the high-speed pulse output, configure its settings in F3.06 rather than F3.02.

### 5.9.2 Analog Output AO

F3.10	AO1 Offset Coefficient	Range:-100.0~+100.0	Default:0.0
F3.11	AO1 Gain	Range:-10.00~+10.00	Default:1.00

These parameters correct the zero drift of analog output and the output amplitude deviation. They can also be used to customize the desired AO curve.

If "b" represents zero offset, "k" represents the gain, "Y" represents the actual output, and "X" represents the standard output, then the actual output is:  $Y = kX + b$ .

The zero offset coefficient 100% of AO1 and AO2 corresponds to 10 V (or 20 mA). The standard output refers to the value corresponding to the analog output of 0 to 10 V (or 0 to 20 mA) with no zero offset or gain adjustment.

For example, if the analog output is used as the operating frequency, and it is expected that the output is 8 V when the frequency is 0 and 3 V at the maximum frequency, the gain shall be set to -0.50, and the zero offset shall be set to 80%.

F3.12	AO2 Offset Coefficient	Range:-100.0~+100.0	Default:0.0
F3.13	AO2 Gain	Range:-10.00~+10.00	Default:1.00

Refer to F3.10 and F3.11.

## Chapter 6 Function Parameter List

The symbols in the function code table are described as follow:

“●” : represents the parameter can be modified while the inverter is operating;

“○” : represents the parameter cannot be modified while the inverter is operating;

“◇” : represents the parameter is the measured value and cannot be modified;

“X” : represents “Factory Parameter”, which is subject to the manufacturer only.

Function Codes	Parameter Name	Range of Settings	Default	Property
F0.00	G/P Type Display	1: G Type (Constant Torque Load) 2: P Type (Variable Torque Load e.g. Fan and Pump)	Model Dependent	○
F0.01	Motor Control Mode	0: Sensor-less Flux Vector Control(SVC) 1: Closed-Loop Vector Control(FVC) 2: Voltage/Frequency (V/F)Control	2	○
F0.02	Operation Command Source Selection	0: Keyboard Control 1: Terminal Control 2: Communication Control	0	●
F0.03	Main Frequency(X) Source Selection	0: Digital Setting (don't save at power failure) 1: Digital Setting (save at power failure) 2: AI1 3: AI2 4: AI3 5: Pulse Setting (X5) 6: Multiple Commands 7: Simple PLC 8: PID 9: Communication Setting 10: AI1+AI2 11: AI1-AI2 12: max(AI1, AI2) 13: min(AI1, AI2)	4	○
F0.04	Auxiliary Frequency(Y) Source Selection	Same as F0.03	0	○
F0.05	Selection Range of Auxiliary Frequency Y for X and Y	0: Relative to the Maximum Frequency 1: Relative to the Main Speed	0	●
F0.06	Range of Auxiliary Frequency Y for X and Y	0%~150%	100%	●

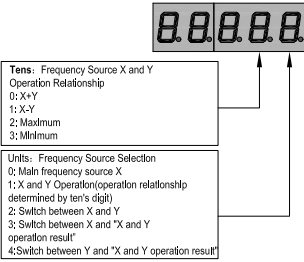
Function Codes	Parameter Name	Range of Settings	Default	Property
F0.07	Frequency Source Selection	 <p><b>Tens:</b> Frequency Source X and Y Operation Relationship                      0: X+Y                      1: X-Y                      2: Maximum                      3: Minimum</p> <p><b>Units:</b> Frequency Source Selection                      0: Main frequency source X                      1: X and Y Operation(operation relationship determined by ten's digit)                      2: Switch between X and Y                      3: Switch between X and "X and Y operation result"                      4: Switch between Y and "X and Y operation result"</p>	00	●
F0.08	Digital Frequency	0.00 to Maximum Frequency (valid when frequency source is set as digital)	50.00Hz	●
F0.09	Rotation Direction	0: Forward 1: Reverse	0	●
F0.10	Maximum Frequency	50.00 Hz~320.00 Hz	50.00Hz	○
F0.11	Source of Frequency Upper Limit	0: Set by F0.12 1: AI1 2: AI2 3: AI3 4: Pulse Setting (X5) 5: Communication Setting	0	○
F0.12	Upper Limit of Frequency	Lower Limit of Frequency (F0.14) to Maximum Frequency (F0.10)	50.00 Hz	●
F0.13	Upper Limit Offset of Frequency	0.00 Hz to Maximum Frequency(F0.10)	0.00 Hz	●
F0.14	Lower Limit of Frequency	0.00 Hz to Upper Limit of Frequency(F0.12)	0.00 Hz	●
F0.15	Carrier Frequency	0.5kHz~16.0 kHz	Model Dependent	●
F0.16	Adjust with Temperature (Carrier Frequency)	0: No 1: Yes	1	●
F0.17	Acceleration Time 1	0.00s~65000s	Model Dependent	●
F0.18	Deceleration Time 1	0.00s~65000s	Model Dependent	●
F0.19	Frequency Offset of Auxiliary Frequency Source for X and Y Operation	0.00 Hz to Maximum Frequency (F0.10)	0.00 Hz	●

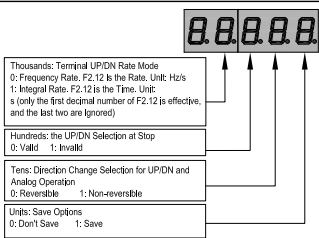
Function Codes	Parameter Name	Range of Settings	Default	Property
F0.20	Digital Frequency Property Selection		0	●
F0.21	Base Frequency of Acceleration/Deceleration time	0: Maximum Frequency (F0.10) 1: Set Frequency 2: 100 Hz	0	○
F0.22	Frequency Reference for UP/DOWN During Operation	0: Operating Frequency 1: Set Frequency	0	○
F0.23	User Password	0-65535	0	●
F0.24	Restore Default Settings	0: No Operation 1: Restore factory settings except motor parameters 2: Clear records	0	○
F0.25	Personalized Menu Display Options	Units(Quick Menu Display Selection) 0: No Display 1: Display Tens(User-modified Menu Display Selection) 0: No Display 1: Display	00	●
F0.26	Parameter Modification Property	0: Modifiable 1: Non-modifiable	0	●
F0.28	The Number of Decimal Places	1: 1 Decimal Places 2: 2 Decimal Places	2	○
<b>Group F1: Motor Parameters</b>				
F1.00	Motor Model	0: Common Asynchronous Motor 1: Variable Frequency Motor	0	○
F1.01	Motor Rated Power	0.1kW~1000.0kW	Model Dependent	○
F1.02	Motor Rated Voltage	1V~2000V	Model Dependent	○
F1.03	Motor Rated Current	0.01~655.35 A (Inverter Power ≤ 55 kW) 0.1~6553.5 A (Inverter Power > 55 kW)	Model Dependent	○
F1.04	Motor Rated Frequency	0.01 Hz to Maximum Frequency	Model Dependent	○
F1.05	Motor Rated Speed	1~65535 RPM	Model Dependent	○



Function Codes	Parameter Name	Range of Settings	Default	Property
F1.06	Motor Stator Resistance	0.001–65.535 Ω (Inverter Power ≤ 55 kW) 0.0001–6.5535 Ω (Inverter Power > 55 kW)	Harmonic Parameters	○
F1.07	Rotor Resistance	0.001–65.535 Ω (Inverter Power ≤ 55 kW) 0.0001–6.5535 Ω (Inverter Power > 55 kW)	Harmonic Parameters	○
F1.08	Motor Leakage Inductance	0.01–655.35 mH (Inverter Power ≤ 55 kW) 0.001–65.535 mH (Inverter Power > 55 kW)	Harmonic Parameters	○
F1.09	Motor Mutual Inductance	0.1–6553.5 mH (Inverter Power ≤ 55 kW) 0.01–655.35 mH (Inverter Power > 55 kW)	Harmonic Parameters	○
F1.10	No-Load Current	0.01 to F1-03 (Inverter Power ≤ 55 kW) 0.1 to F1-03 (Inverter Power > 55 kW)	Harmonic Parameters	○
F1.27	Encoder Pulses per Revolution	1–65535	1024	○
F1.30	A/B Phase Sequence of ABZ Incremental Encoder	0: Forward 1: Reserve	0	○
F1.37	Self-Identification of Motor Parameters	0: No Identification 1: Static Self-Identification 2: Complete Self-Identification	0	○

Function Codes	Parameter Name	Range of Settings	Default	Property
<b>Group F2: Input Terminals</b>				
F2.00	X1 Function Selection	0: No Function	1	○
F2.01	X2 Function Selection	1: Forward RUN (FWD)	4	○
F2.02	X3 Function Selection	2: Reverse RUN (REV) 3: Three-Wire Control	9	○
F2.03	X4 Function Selection	4: Forward JOG (FJOG)	12	○
F2.04	X5 Function Selection	5: Reverse JOG (RJOG)	13	○
F2.05	X6 Function Selection	6: Terminal UP	0	○
F2.06	X7 Function Selection	7: Terminal DOWN	0	○
F2.07	X8 Function Selection	8: Coasting to Stop	0	○
F2.08	X9 Function Selection	9: Fault Reset (RESET) 10: Operation Pause	0	○
F2.09	X10 Function Selection	11: Normally Open (NO) Input of External Fault 12: Multi-Command Terminal 1 13: Multi-Command terminal 2 14: Multi-Command terminal 3 15: Multi-Command terminal 4 16: Terminal 1 for Acceleration/Deceleration Time Selection 17: Terminal 2 for Acceleration/Deceleration Time Selection 18: Frequency Source Switch 19: UP and DOWN Settings Clear 20: Switch to keyboard control 21: Acceleration /Deceleration Prohibition 22: PID Pause 23: PLC Status Reset 24: Swing Frequency Pause 25: Counter Input 26: Counter Reset 27: Length Count Input 28: Length Reset 29: Torque Control Prohibition 30: Pulse Input (Enabled Only for X5) 31:Reserved 32: Immediate DC Braking 33: Normally Closed (NC) Input of External Fault 34: Frequency Modification Enabling 35: Reverse PID Direction 36: External STOP Terminal 1 37: Switch Over Terminals by Command Source 38: PID Integral Pause 39: Switch between main frequency source X and digital Frequency 40: Switch between auxiliary frequency source Y and digital freq. 41: PID Parameters Switch 42: User-Defined Fault 1 43: User-Defined Fault 2 44: Speed Control / Torque Control Switch 45:Emergency Stop 46: External STOP Terminal 2 47: Deceleration DC Braking 48: Current Operating Time Clear	0	○

Function Codes	Parameter Name	Range of Settings	Default	Property
F2.10	Terminal X Filter Time	0.000s~1.000s	0.010s	●
F2.11	Terminal Command Mode	0: Two-Wire Mode 1 1: Two-Wire Mode 2 2: Three-Wire Mode 1 3: Three-Wire Mode 2	0	○
F2.12	Terminal UP/DOWN Rate of Change	0.01Hz/s~65.535 Hz/s	1.00Hz/s	●
F2.13	AI1 Filter Time	0.00s~10.00s	0.10s	●
F2.14	AI2 Filter Time	0.00s~10.00s	0.10s	●
F2.15	AI3 Filter Time	0.00s~10.00s	0.10s	●
F2.16	AI Curve 1 Minimum Input	0.00V~F2.18	0.20V	●
F2.17	Corresponding Setting of AI Curve 1 Minimum Input	-100.0%~+100.0%	0.0%	●
F2.18	AI Curve 1 Maximum Input	F2.16~+10.00V	10.00V	●
F2.19	Corresponding Setting of AI Curve 1 Maximum Input	-100.0%~+100.0%	100.0%	●
F2.20	AI Curve 2 Minimum Input	0.00V~F2.22	0.20V	●
F2.21	Corresponding Setting of AI Curve 2 Minimum Input	-100.0%~+100.0%	0.0%	●
F2.22	AI Curve 2 Maximum Input	F2.20~+10.00V	10.00V	●
F2.23	Corresponding Setting of AI Curve 2 Maximum Input	-100.0%~+100.0%	100.0%	●
F2.24	AI Curve 3 Minimum Input	0.00V~F2.26	0.20V	●
F2.25	Corresponding Setting of AI Curve 3 Minimum Input	-100.0%~+100.0%	0.0%	●
F2.26	AI Curve 3 Maximum Input	F2.24~+10.00V	10.00V	●
F2.27	Corresponding Setting of AI Curve 3 Maximum Input	-100.0%~+100.0%	100.0%	●
F2.28	PULSE Minimum Input	0.00kHz~F2.30	0.00kHz	●
F2.29	Corresponding Setting of PULSE Minimum Input	-100.0%~100.0%	0.0%	●
F2.30	PULSE Maximum Input	F2.28~100.00kHz	50.00kHz	●
F2.31	Corresponding Setting of PULSE Maximum Input	-100.0%~100.0%	100.0%	●

Function Codes	Parameter Name	Range of Settings	Default	Property
F2.32	PULSE Filter Time	0.00s~10.00s	0.10s	●
F2.33	AI Curve Selection	<p>Hundreds: AI3 curve selection Curve 1 to Curve 5 same as AI1</p> <p>Tens: AI2 Curve Selection Curve 1 to Curve 5 same as AI1</p> <p>Units: AI1 Curve Selection Curve 1 ( 2 points, see F2.16 to F2.19) Curve 2 ( 2 points, see F2.20 to F2.23) Curve 3 ( 2 points, see F2.24 to F2.27) Curve 4 ( 4 points, see P0.00 to P0.07) Curve 5 ( 4 points, see P0.08 to P0.15)</p>	321	●
F2.34	Setting for AI Less Than Minimum Input	<p>Hundreds (Setting for AI3 Less Than Minimum Input) 0, 1 (same as AI1)</p> <p>Tens (Setting for AI2 Less Than Minimum Input) 0, 1 (same as AI1)</p> <p>Units (Setting for AI1 Less Than Minimum Input) 0: Minimum Value 1: 0.0%</p>	000	●
F2.35	X1 switch-on delay	0.0s~3600.0s	0.0s	●
F2.36	X1 switch-off delay	0.0s~3600.0s	0.0s	●
F2.37	X2 switch-on delay	0.0s~3600.0s	0.0s	●
F2.38	X2 switch-off delay	0.0s~3600.0s	0.0s	●
F2.39	X3 switch-on delay	0.0s~3600.0s	0.0s	●
F2.40	X3 switch-off delay	0.0s~3600.0s	0.0s	●
F2.41	Terminal X Valid Mode Selection	0: High Level Valid 1: Low Level Valid Units:X1 Tens:X2 Hundreds:X3 Thousands:X4 Ten thousands:X5	00000	○

Function Codes	Parameter Name	Range of Settings	Default	Property
Group F3:Output Terminals				
F3.00	Y2/DO Terminal Output Mode	0:Pulse Output (DO) 1:Switch Signal Output (Y2)	1	●
F3.01	Y1 Output Function Selection	0: No Output 1: Inverter Running	1	●
F3.02	Y2 Output Function Selection	2: Output Errors (Stop) 3: Frequency Level Detection of FDT1 Output 4: Frequency Reached 5: Zero-Speed (No Output at Stop) 6: Motor Overload Pre-alarm 7: Inverter Overload Pre-alarm 8: Set count value reached 9: Designated count value reached 10: Length Reached 11: PLC Cycle Complete 12: Accumulated Operating Time Reached 13: Frequency Limited 14: Torque Limited 15: Ready for RUN 16: AI1 > AI2 17: Frequency Upper Limit Reached 18: Frequency Lower Limit Reached(No Output at Stop)	0	●
F3.03	Relay R Output Function Selection	19: Under Voltage State Output 20: Communication Setting 21: Reserved 22: Reserved 23: Zero-Speed Operating 2 (Having Output at Stop) 24: Accumulated Power-On Time Reached 25: Frequency Level Detection FDT2 Output	2	●
F3.04	Relay E Output Function Selection	26: Frequency 1 Reached 27: Frequency 2 Reached 28: Current 1 Reached 29: Current 2 Reached 30: Timing Reached 31: AI1 Input Limit Exceeded 32: Load Becoming 0 33: Reverse Operation 34: Zero Current Status 35: Module Temperature Reached 36: Output Current Limit Exceeded 37: Frequency Lower Limit Reached (Having Output at Stop) 38: Alarm Output 39: Motor Overheat Warning 40: Current Operating Time Reached 41:Analog Levels:ADT1 42:Analog Levels:ADT2 44:X1 Status 45:X2 Status	0	●
F3.05	Reserved		0	●

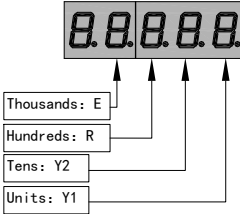
Function Codes	Parameter Name	Range of Settings	Default	Property
F3.06	DO Output Function Selection	0: Operating Frequency	0	●
F3.07	AO1 Output Function Selection	1: Set Frequency	0	●
F3.08	AO2 Output Function Selection	2: Output Current 3: Output Torque (Absolute Value) 4: Output Power 5: Output Voltage 6: Pulse Input 7: AI1 8: AI2 9: AI3 10: Length 11: Count Value 12: Communication Setting 13: Motor Rotational Speed 14: Output Current 15: Output Voltage 16: Reservation	1	●
F3.09	Maximum Output Frequency of DO	0.01kHz~100.00kHz	50.00kHz	●
F3.10	AO1 Offset Coefficient	-100.0%~+100.0%	0.0%	●
F3.11	AO1 Gain	-10.00~+10.00	1.00	●
F3.12	AO2 Offset Coefficient	-100.0%~+100.0%	0.0%	●
F3.13	AO2 Gain	-10.00~+10.00	1.00	●
F3.14	Y1 switch-on delay	0.0s~3600.0s	0.0s	●
F3.15	Y1 switch-off delay	0.0s~3600.0s	0.0s	●
F3.16	Y2 switch-on delay	0.0s~3600.0s	0.0s	●
F3.17	Y2 switch-off delay	0.0s~3600.0s	0.0s	●
F3.18	R-relay switch-on delay	0.0s~3600.0s	0.0s	●
F3.19	R-relay switch-off delay	0.0s~3600.0s	0.0s	●
F3.20	E-relay switch-on delay	0.0s~3600.0s	0.0s	●
F3.21	E-relay switch-off delay	0.0s~3600.0s	0.0s	●
F3.22	Monopulse Output Time Y1	0.0s~30.0s	0.0s	●
F3.23	Monopulse Output Time Y2	0.0s~30.0s	0.0s	●
F3.24	Monopulse Output Time Relay R	0.0s~30.0s	0.0s	●
F3.25	Monopulse Output Time Relay E	0.0s~30.0s	0.0s	●
F3.27	DO Valid Mode Selection	0: Positive Logic 1: Negative Logic 	0000	●

Function Codes	Parameter Name	Range of Settings	Default	Property
Group F4: Auxiliary Parameters				
F4.00	JOG Operating Frequency	0.00 Hz to Maximum Frequency	2.00Hz	●
F4.01	JOG Acceleration Time	0.0s~6500.0s	20.0s	●
F4.02	JOG Deceleration Time	0.0s~6500.0s	20.0s	●
F4.03	Acceleration Time 2	0.0s~6500.0s	Model Dependent	●
F4.04	Deceleration Time 2	0.0s~6500.0s	Model Dependent	●
F4.05	Acceleration Time 3	0.0s~6500.0s	Model Dependent	●
F4.06	Deceleration Time 3	0.0s~6500.0s	Model Dependent	●
F4.07	Acceleration Time 4	0.0s~6500.0s	Model Dependent	●
F4.08	Deceleration Time 4	0.0s~6500.0s	Model Dependent	●
F4.09	Jump Frequency 1	0.00 Hz to Maximum Frequency	0.00Hz	●
F4.10	Jump Frequency 2	0.00 Hz to Maximum Frequency	0.00Hz	●
F4.11	Jump Frequency Amplitude	0.00 Hz to Maximum Frequency	0.01Hz	●
F4.12	Forward/Reverse Rotation Dead time	0.0s~3000.0s	0.0s	●
F4.13	Reverse Control	0: Enabled 1: Disabled	0	●
F4.14	Operating Mode (Set frequency is lower than the lower limit of frequency)	0: Run at frequency lower limit 1: Stop 2: Run at zero speed	0	●
F4.15	Droop Control	0.00Hz~10.00Hz	0.00Hz	●
F4.16	Accumulated Power-On Time Threshold	0h~65000h	0h	●
F4.17	Accumulated Operating Time Threshold	0h~65000h	0h	●
F4.18	Start-Up Protection	0: No 1: Yes	0	●
F4.19	Frequency Detection Value (FDT1)	0.00 Hz to Maximum Frequency	50.00Hz	●
F4.20	Frequency Detection Hysteresis(FDT 1)	0.0%~100.0% (F4.19)	5.0%	●
F4.21	Detection Range of Frequency Reached	0.0%~100.0 (Maximum Frequency)	0.0%	●
F4.22	Jump Frequency During Acceleration /Deceleration	0: Disabled 1: Enabled	0	●
F4.25	Frequency Points Switch Between Acceleration Time 1 and Acceleration Time 2	0.00 Hz to Maximum Frequency	0.00Hz	●
F4.26	Frequency Points Switch Between Deceleration Time 1 and Deceleration Time 2	0.00 Hz to Maximum Frequency	0.00Hz	●

Function Codes	Parameter Name	Range of Settings	Default	Property
F4.27	Terminal JOG Preferred	0: Disabled 1: Enabled	0	●
F4.28	Frequency Detection Value(FDT2)	0.00 Hz to Maximum Frequency	50.00Hz	●
F4.29	Frequency Detection Hysteresis(FDT 2)	0.0%~100.0% (FDT2 Level)	5.0%	●
F4.30	Any Frequency Reaching Detection Value 1	0.00 Hz to Maximum Frequency	50.00Hz	●
F4.31	Any Frequency Reaching Detection Amplitude 1	0.0%~100.0% (Maximum Frequency)	0.0%	●
F4.32	Any Frequency Reaching Detection Value 2	0.00 Hz to Maximum Frequency	50.00Hz	●
F4.33	Any Frequency Reaching Detection Amplitude 2	0.0%~100.0% (Maximum Frequency)	0.0%	●
F4.34	Zero Current Detection Level	0.0%~300.0% 100.0% corresponds to rated motor current.	5.0%	●
F4.35	Zero Current Detection Delay Time	0.01s~600.00s	0.10s	●
F4.36	Output Over current Threshold	0.0% (No Detection) 0.1%~300.0% (Rated Motor Current)	200.0%	●
F4.37	Output Over current Detection Delay Time	0.00s~600.00s	0.00s	●
F4.38	Any Current Reaching 1	0.0%~300.0%(Rated Motor Current)	100.0%	●
F4.39	Any Current Reaching 1 Amplitude	0.0%~300.0%(Rated Motor Current)	0.0%	●
F4.40	Any Current Reaching2	0.0%~300.0%(Rated Motor Current)	100.0%	●
F4.41	Any Current Reaching 2 Amplitude	0.0%~300.0%(Rated Motor Current)	0.0%	●
F4.42	Timing Function	0: Disabled 1: Enabled	0	●
F4.43	Timer Selection of Operating Time	0:F4.44 1:A11 2:A12 3:A13(Analog input corresponds to F4.14)	0	●
F4.44	Timing Duration	0.0 Min~6500.0 Min	0.0 Min	●
F4.45	Lower Limit of A11 Input Voltage Protection	0.00V~F4.46	3.10V	●
F4.46	Upper Limit of A11 Input Voltage Protection	F4.45~10.00V	6.80V	●
F4.47	Module Temperature Threshold	0℃~100℃	75℃	●
F4.48	Cooling Fan Control	0: Fan working during operating 1: Fan working continuously	0	●
F4.49	Wakeup Frequency	Dormancy frequency (F4.51) to Maximum Frequency (F0.10)	0.00Hz	●
F4.50	Wakeup Delay Time	0.0s~6500.0s	0.0s	●
F4.51	Dormancy Frequency	0.00Hz to Wakeup Frequency (F4.49)	0.00Hz	●
F4.52	Dormancy Delay Time	0.0s~6500.0s	0.0s	●



Function Codes	Parameter Name	Range of Settings	Default	Property
F4.53	Current Operating Time Reached	0.0Min~6500.0Min	0.0Min	●
F4.54	ADT1 Channel Selection		00	●
F4.55	ADT2 Channel selection		01	●
F4.56	ADT1 Output Upper Limit	F4.57~10.00	10.00V	●
F4.57	ADT1 Output Lower Limit	0.00~F4.56	0.00V	●
F4.58	ADT2 Output Upper Limit	F4.59~10.00	10.00V	●
F4.59	ADT2 Output Lower Limit	0.00~F4.58	0.00V	●
<b>Group F5: Vector Control Parameters</b>				
F5.00	Speed Loop Proportion Gain 1	1~100	30	●
F5.01	Speed Loop Integral Time 1	0.01s~10.00s	0.50s	●
F5.02	Frequency Switch1	0.00~A2.05	5.00Hz	●
F5.03	Speed Loop Proportion Gain 2	1~100	20	●
F5.04	Speed Loop Integral Time 2	0.01s~10.00s	1.00s	●
F5.05	Frequency Switch 2	F5.02 to Maximum Output Frequency	10.00Hz	●
F5.06	Slip Gain of Vector Control	50%~200%	100%	●
F5.07	Time Constant of Speed Loop Filter	0.000s~0.100s	0.000s	●
F5.08	Over excitation Gain of Vector Control	0~200	64	●
F5.09	Upper Limit of Torque Source in Speed Control Mode	0: F5.10 1: AI1 2: AI2 3: AI3 4: Pulse Setting (X5) 5: Communication Setting 6: MIN(AI1, AI2) 7: MAX(AI1, AI2)	0	●
F5.10	Digital Setting of Torque Upper Limit in Speed Control Mode	0.0%~200.0%	150.0%	●

Function Codes	Parameter Name	Range of Settings	Default	Property
F5.13	Proportion Gain of Excitation Adjustment	0~60000	2000	●
F5.14	Integral Gain of Excitation Adjustment	0~60000	1300	●
F5.15	Proportion Gain of Torque Adjustment	0~60000	2000	●
F5.16	Integral Gain of Torque Adjustment	0~60000	1300	●
F5.17	Integral Separation of Speed Loop	0: Invalid 1: Valid	0	●
F5.18	Torque Limit Coefficient of Field Weakening	50~150	80	●
F5.19	Bandwidth of Flux Closed Loop	0~5.00	2.00	●
F5.20	Minimum Set Value of Flux	30~100	30	○
F5.21	Torque Switch	0~50.0	20.0	●
F5.22	Over excitation Enabling	0: Invalid 1: Valid	0	●
Group F6: V/F Control Parameters				
F6.00	V/F Curve Setting	0: Linear V/F 1: Multipoint V/F 2: Square V/F 3: 1.2-power V/F 4: 1.4-power V/F 6: 1.6-power V/F 8: 1.8-power V/F	0	○
F6.01	Torque Boost	0.0%: (Automatic Torque Boost) 0.1%~30.0%	Model Dependent	●
F6.02	Cut-off Frequency of Torque Boost	0.00 Hz to Maximum Output Frequency	50.00Hz	○
F6.03	Multi-point V/F Freq. 1	0.00Hz~F6.05	0.00Hz	○
F6.04	Multi-point V/F Voltage 1	0.0%~100.0%	0.0%	○
F6.05	Multi-point V/F Freq. 2	F6.03~F6.07	0.00Hz	○
F6.06	Multi-point V/F Voltage 2	0.0%~100.0%	0.0%	○
F6.07	Multi-point V/F Freq. 3	F6.05 to Rated Motor Freq. (F1.04)	0.00Hz	○
F6.08	Multi-point V/F Voltage 3	0.0%~100.0%	0.0%	○
F6.09	V/F Slip Compensation Gain	0.0%~200.0%	0.0%	●
F6.10	V/F Over-excitation Gain	0~200	64	●
F6.11	V/F Oscillation Suppression Gain	0~100	Model Dependent	●
F6.13	Selection for Limited Current Protection	0~1	0	○
F6.14	Limited Current Protection Value	0~600	70A	●
F6.15	Limited Current Protection Time	0.0~60.0	02.0s	●
F6.16	V/F Current limit selection	0: Invalid 1: Valid	1	●
F6.17	V/F Current limit level	50%~200%	150%	●

Function Codes	Parameter Name	Range of Settings	Default	Property
F6.18	Current limit gain	0~100	20	●
F6.19	Compensation factor of speed multiplying current limit level	50%~200%	50%	●
F6.20	Voltage limit selection	0: Invalid 1: Valid ( V/F and SVC)	0	●
F6.21	Voltage limit	120%~150% ( V/F and SVC)	130%	●
F6.22	Frequency gain for voltage limit	0~100 (V/F and SVC)	30	●
F6.23	Voltage gain for voltage limit	0~100	40	●
F6.24	Frequency rise threshold during voltage limit	0~50.00	5.00	●
F6.25	Filter Time of V/f Slip Compensation	0~10.0	4.0	●
F6.26	Auto-Torque Boost Coefficient	0~200	100	●
<b>Group F7: Start/Stop Control Parameters</b>				
F7.00	Start Mode	0: Direct Start 1: Speed tracking then start 2: DC braking then start	0	●
F7.01	Speed Tracking Mode	0: Start from the frequency at stop 1: Start from zero speed 2: Start from the maximum frequency	0	○
F7.02	Speed of Speed Tracking	1~100	20	●
F7.03	Startup Frequency	0.00Hz~10.00Hz	0.00Hz	●
F7.04	Hold Time of Startup Frequency	0.0s~100.0s	0.0s	○
F7.05	Startup DC Braking Current	0%~100%	0%	○
F7.06	Startup DC Braking Time	0.0s~100.0s	0.0s	○
F7.07	Acceleration / Deceleration Mode	0: Linear Acceleration / Deceleration 1: S-curve Acceleration / Deceleration A 2: S-curve Acceleration / Deceleration B	0	○
F7.08	Time Proportion of the Start Segment of S-curve	0.0%~ ( 100.0%-F7.09 )	30.0%	○
F7.09	Time Proportion of the End Segment of S-curve	0.0%~ ( 100.0%-F7.08 )	30.0%	○
F7.10	Stop Mode	0: Decelerate to Stop 1: Coast to Stop	0	●
F7.11	Initial Frequency of DC Braking at Stop	0.00 Hz to maximum frequency	0.00Hz	●
F7.12	Waiting Time of DC Braking at Stop	0.0s~100.0s	0.0s	●
F7.13	DC Braking Current at Stop	0%~100%	0%	●
F7.14	DC Braking Time at Stop	0.0s~100.0s	0.0s	●
F7.15	Use Rate of Braking	0%~100%	100%	●

Function Codes	Parameter Name	Range of Settings	Default	Property
F7.16	Rotational Speed Tracking Current	20%~200%	100%	●
F7.17	Rotational Speed Tracking KP	0~1000	500	●
F7.18	Rotational Speed Tracking KI	0~1000	800	●
F7.19	Rotational Speed Tracking Demagnetization Time	0.00s~10.00s	1.00	●
Function Codes	Parameter Name	Range of Settings	Default	Property
<b>Group F8: Operation Panel and Display Parameters</b>				
F8.01	MK Key Function Selection	0: Menu Switch 1: Switch Between Operation Panel Control and Remote Command Control (Terminals or Communication) 2: Switch Between Forward and Reverse Rotation 3: Forward JOG 4: Reverse JOG	0	○
F8.03	LED Display Parameters in Operation 1	0000~FFFF Bit00: Operating Frequency (Hz) Bit01: Set Frequency (Hz) Bit02: Output Current (A) Bit03: Output Voltage (V) Bit04: Output Power (kW) Bit05: Output Torque (%) Bit06: Bus Voltage (V) Bit07: Terminal X Input Status 1 Bit08: Reserved Bit09: Digital Output Status Bit10: AI1 Voltage (V) Bit11: AI2 Voltage (V) Bit12: AI3 Voltage (V) Bit13: Pulse Input Frequency(kHz) Bit14: PID Setting Bit15: PID Feedback	1F	●
F8.04	LED Display Operating Parameters 2	0000~FFFF Bit00: PID Output Bit01: Load Speed Display Bit02: Main Frequency Display(Hz) Bit03: Auxiliary Frequency Display Bit04: Feedback Speed Bit05: Count Value Bit06: Length Value Bit07: Linear speed Bit08: Current Power-On Time(Hour) Bit09: Current Operating Time (Min) Bit10: Overload Count Bit11: Output Current Percentage(%) Bit12: Remaining Operating Time Bit13: PLC Phase Bit14: Communication Setting Value	0	●

F8.05	LED Display Parameters at Stop	0000~FFFF Bit00: Set Frequency (Hz) Bit01: Bus Voltage (V) Bit02: Terminal X Input Status Bit03: Digital Output Status Bit04: AI1 Voltage (V) Bit05: AI2 Voltage (V) Bit06: AI3 Voltage (V) Bit07: Count Value Bit08: Length Value Bit09: PLC Phase Bit10: Load Speed Bit11: PID Setting Bit12:Pulse Setting Frequency (kHz)	33	●
F8.06	Display Coefficient of Load Speed	0.0001~6.5000	3.0000	●
F8.07	Radiator Temperature of Inverter Module	0.0°C~100.0°C		◇
F8.09	Accumulated Operating Time	0h~65535h		◇
F8.11	Software Version			◇
F8.12	Number of Decimal Places for Load Speed Display	0: 0 Decimal Places 1: 1 Decimal Place 2: 2 Decimal Places 3: 3 Decimal Places	1	●
F8.13	Accumulated Power-On Time	0h~65535h		◇
F8.14	Accumulated Power Consumption	0~65535 kWh		◇
<b>Group F9: Fault and Protection Parameters</b>				
Function Codes	Parameter Name	Range of Settings	Default	Property
F9.00	Motor Overload Protection	0: Disabled 1: Enabled	1	●
F9.01	Motor Overload Protection Gain	0.20~10.00	1.00	●
F9.02	Motor Overload Pre-warning Coefficient	50%~100%	80%	●
F9.07	Detection of short-circuit to ground upon power-on	0: Disabled 1: Enabled	1	●
F9.09	Auto Reset times	0~20	0	●
F9.10	Selection of DO action during auto reset	0: Not act 1: Act	0	●
F9.11	Time Interval of Fault Auto Reset	0.1s~100.0s	1.0s	●
F9.12	Input phase Loss / pre-charge relay Protection	Units: Input Phase Loss Protection Tens: pre-charge relay Protection 0: Disabled 1: Enabled	10	●
F9.13	Output Phase Loss Protection	0: Disabled 1: Enabled	1	●
F9.09	Times of Faults Auto Reset	0~20	0	●

Function Codes	Parameter Name	Range of Settings	Default	Property
F9.14	1st fault type	0: No Error 1: Reserved 2:Over-current during Acceleration 3:Over-current during Deceleration 4: Over-current at a Constant Speed 5: Over-voltage during Acceleration 6: Over-voltage during Deceleration 7: Over-voltage at a Constant Speed 8:Buffer Resistor Overload		
F9.15	2nd fault type	9: Under-voltage 10: Inverter Overload 11: Motor Overload 12:Power Input Phase Loss 13: Power Output Phase Loss 14: Module Overheated 15: External Parts Error 16: Communication Errors 17: pre-charge relay Fault 18: Current Detection Errors 19: Motor Auto-tuning Errors 20: Encoder/PG Card Errors 21: EEPROM Read-Write Errors 22: Inverter Hardware Errors 23: Motor Short to Ground 24: Reserved		
F9.16	3rd (latest) fault type	25: Reserved 27: User-Defined Fault 1 28: User-Defined Fault 2 29:Accumulated Power-On Time Reached 30: Load Drop 31:PID Feedback Lost during Operating 40: Fault Current Limit Over-time 42: Large Speed Deviation 43: Motor Over-speed 51: Faulty Initial Position		
F9.17	Frequency upon 3rd Error	—	—	◇
F9.18	Current upon 3rd Error	—	—	◇
F9.19	Bus Voltage upon 3rd Error	—	—	◇
F9.20	Input Terminal Status upon 3rd Error	—	—	◇
F9.21	Inverter Temperature upon 3rd Error	—	—	◇
F9.22	Inverter Status upon 3rd Error	—	—	◇
F9.23	Power-on Time upon 3rd Error	—	—	◇
F9.24	Operating Time upon 3rd Error	—	—	◇
F9.27	Frequency upon 2nd Error	—	—	◇
F9.28	Current upon 2nd Error	—	—	◇
F9.29	Bus Voltage upon 2nd Error	—	—	◇

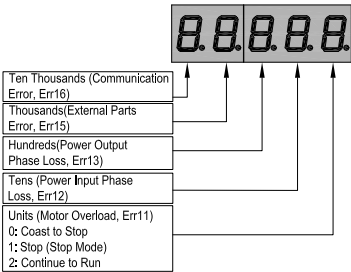
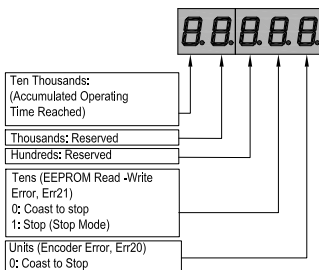
F9.30	X Status upon 2nd Error	—	—	◇
F9.31	Inverter Temperature upon 2nd Error	—	—	◇
F9.32	Inverter Status upon 2nd Error	—	—	◇
F9.33	Power-on Time upon 2nd Error	—	—	◇
F9.34	Operating Time upon 2nd Error	—	—	◇
F9.37	Frequency upon 1st Error	—	—	◇
F9.38	Current upon 1st Error	—	—	◇
F9.39	Bus Voltage upon 1st Error	—	—	◇
F9.40	X Status upon 1st Error	—	—	◇
F9.41	Inverter Temperature upon 1st Error	—	—	◇
F9.42	Inverter Status upon 1st Error	—	—	◇
F9.43	Power-on Time upon 1st Error	—	—	◇
F9.44	Operating Time upon 1st Error	—	—	◇
F9.47	Selection for Fault Protection Actions 1		00000	●
F9.48	Selection for Fault Protection Actions 2		00000	●

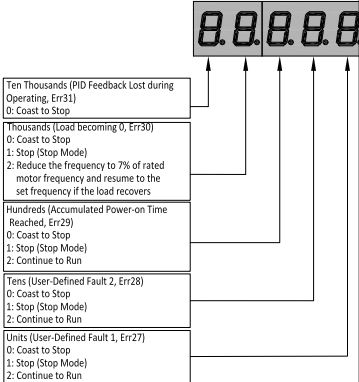
<p>F9.49</p>	<p>Selection for Fault Protection Actions 3</p>	 <p>Ten Thousands (PID Feedback Lost during Operating, Err31) 0: Coast to Stop</p> <p>Thousands (Load becoming 0, Err30) 0: Coast to Stop 1: Stop (Stop Mode) 2: Reduce the frequency to 7% of rated motor frequency and resume to the set frequency if the load recovers</p> <p>Hundreds (Accumulated Power-on Time Reached, Err29) 0: Coast to Stop 1: Stop (Stop Mode) 2: Continue to Run</p> <p>Tens (User-Defined Fault 2, Err28) 0: Coast to Stop 1: Stop (Stop Mode) 2: Continue to Run</p> <p>Units (User-Defined Fault 1, Err27) 0: Coast to Stop 1: Stop (Stop Mode) 2: Continue to Run</p>	<p>00000</p>	<p>●</p>
<p>F9.50</p>	<p>Selection for Fault Protection Actions 4</p>	<p>Units (Large Speed Deviation,Err42) 0: Coast to Stop 1: Stop (Stop Mode) 2: Continue to Run</p>	<p>00000</p>	<p>●</p>
<p>F9.54</p>	<p>Selection for Operating Frequency When Error Occurs</p>	<p>0:Current Operating Frequency 1: Set Frequency 2: Frequency Upper Limit 3: Frequency Lower Limit 4: Backup Frequency Upon Faults</p>	<p>0</p>	<p>●</p>
<p>F9.55</p>	<p>Backup Frequency Upon Faults</p>	<p>60.0%~100.0% 100.0%: Maximum Frequency (F0.10)</p>	<p>100.0%</p>	<p>●</p>
<p>F9.59</p>	<p>Action Selection at Instantaneous Power Failure</p>	<p>0: Invalid 1: PI Automatic Voltage Stabilization 2: Decelerate According to F4.08</p>	<p>0</p>	<p>●</p>
<p>F9.60</p>	<p>Voltage Check at Instantaneous Power</p>	<p>80.0%~F9.61 (Standard Bus Voltage)</p>	<p>90.0%</p>	<p>●</p>
<p>F9.61</p>	<p>Voltage Check at Instantaneous Power Recovery</p>	<p>F9.60~100.0% (Standard Bus Voltage)</p>	<p>85.0%</p>	<p>●</p>
<p>F9.62</p>	<p>Voltage Recovery Check Time at Instantaneous Power Failure</p>	<p>0.00s~100.00s</p>	<p>0.50s</p>	<p>●</p>
<p>F9.63</p>	<p>Adjusting KP when Inverter does not stop at Instantaneous Power Failure</p>	<p>1~100</p>	<p>40</p>	<p>●</p>
<p>F9.64</p>	<p>Adjusting KI when Inverter does not stop at Instantaneous Power Failure</p>	<p>1~100</p>	<p>30</p>	<p>●</p>
<p>F9.65</p>	<p>Protection upon Load Becoming 0</p>	<p>0: Invalid 1: Valid</p>	<p>0</p>	<p>●</p>
<p>F9.66</p>	<p>Detection Level of Load Becoming 0</p>	<p>0.0~100.0%</p>	<p>10.0%</p>	<p>●</p>
<p>F9.67</p>	<p>Detection Time of Load Becoming 0</p>	<p>0.0~60.0s</p>	<p>1.0s</p>	<p>●</p>

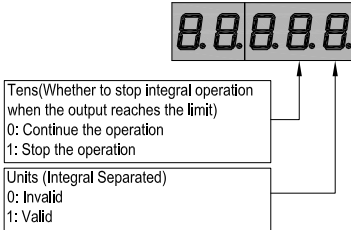

Function Codes	Parameter Name	Range of Settings	Default	Property
F9.69	Over-speed Detection Value	0.0%~50.0% (Maximum Frequency)	20.0%	●
F9.70	Over-speed Detection Time	0.0s~60.0s	1.0s	●
F9.71	Detection Value of Large Speed Deviation	0.0%~50.0% (Maximum Frequency)	20.0%	●
F9.72	Detection Time of Large Speed Deviation	0.0s~60.0s	5.0s	●
F9.61	Voltage Check at Instantaneous Power Recovery	F9.60~100.0% (Standard Bus Voltage)	85.0%	●
<b>Group FA: PID Function Parameters</b>				
FA.00	PID Setting Source	0: FA.01 1: AI1 2: AI2 3: AI3 4: Pulse Setting (DI5) 5: Communication Setting 6: Multi-Command	0	●
FA.01	PID Digital Setting	0.0%~100.0%	50.0%	●
FA.02	PID Feedback Source	0: AI1 1: AI2 2: AI3 3: AI1-AI2 4: Pulse setting (X5) 5: Communication Setting 6: AI1 + AI2 7: MAX (AI1, AI2) 8: MIN (AI1, AI2)	0	●
FA.00	PID Setting Source	0: FA.01 1: AI1 2: AI2 3: AI3 4: Pulse Setting (DI5) 5: Communication Setting 6: Multi-Command	0	●
FA.01	PID Digital Setting	0.0%~100.0%	50.0%	●
FA.02	PID Feedback Source	0: AI1 1: AI2 2: AI3 3: AI1-AI2 4: Pulse setting (X5) 5: Communication Setting 6: AI1 + AI2 7: MAX (AI1, AI2) 8: MIN (AI1, AI2)	0	●
FA.03	PID Direction	0: Forward 1: Reverse	0	●
FA.04	PID Feedback Range	0~65535	1000	●
FA.05	Proportional Gain Kp1	0.0~100.0	20.0	●
FA.06	Integral Time Ti1	0.01s~10.00s	2.00s	●

Function Codes	Parameter Name	Range of Settings	Default	Property
FA.07	Differential Time Td1	0.000s~10.000s	0.000s	●
FA.08	Reverse Cut-off Frequency of PID	0.00 to Maximum Frequency	0.00Hz	●
FA.09	PID Deviation Limit	0.0%~100.0%	0.0%	●
FA.10	PID Differential Limit	0.00%~100.00%	0.10%	●
FA.11	PID Set Time of Change	0.00~650.00s	0.00s	●
FA.12	PID Feedback Filter Time	0.00~60.00s	0.00s	●
FA.13	PID Output Filter Time	0.00~60.00s	0.00s	●
FA.15	Proportional Gain Kp2	0.0~100.0	20.0	●
FA.16	Integral Time Ti2	0.01s~10.00s	2.00s	●
FA.17	Differential Time Td2	0.000s~10.000s	0.000s	●
FA.18	PID Parameter Switch Condition	0: No Switch 1: Switch via Terminal X 2: Automatic Switch Based on Deviation	0	●
FA.19	PID Parameter Switch Deviation 1	0.0%~FA.20	20.0%	●
FA.20	PID Parameter Switch Deviation 2	FA.19~100.0%	80.0%	●
FA.21	PID Initial Value	0.0%~100.0%	0.0%	●
FA.22	Hold Time of PID Initial Value	0.00~650.00s	0.00s	●
FA.23	Maximum Value of Two PID Outputs Deviation in Forward Direction	0.00%~100.00%	1.00%	●
FA.24	Maximum Value of Two PID Outputs Deviation in Reverse Direction	0.00%~100.00%	1.00%	●
FA.25	PID Integral Property		00	●
FA.26	Detection Value of PID Feedback Loss	0.0%: No Judging Feedback Loss 0.1% - 100.0%	0.0%	●
FA.27	Detection Time of PID Feedback Loss	0.0s~20.0s	0.0s	●
FA.28	PID Operation at Stop	0: No PID Operation at Stop 1: PID Operation at Stop	0	●
Group Fb: Swing Frequency, Fixed Length, Count and Torque Control and Restricting Parameters				
Fb.00	Swing Frequency Setting mode	0: Relative to the Central Frequency 1: Relative to the Maximum Frequency	0	●

Function Codes	Parameter Name	Range of Settings	Default	Property
Fb.01	Swing Frequency Amplitude	0.0%~100.0%	0.0%	●
Fb.02	Jump Frequency Amplitude	0.0%~50.0%	0.0%	●
Fb.03	Swing Frequency Cycle	0.1s~3000.0s	10.0s	●
Fb.04	Rise Time Coefficient of Triangular Wave	0.1%~100.0%	50.0%	●
Fb.05	Set Length	0m~65535m	1000m	●
Fb.06	Actual Length	0m~65535m	0m	●
Fb.07	Number of Pulses Per Meter	0.1~6553.5	100.0	●
Fb.08	Set Count Value	1~65535	1000	●
Fb.09	Designated Count Value	1~65535	1000	●
Fb.10	Speed/Torque Control Selection	0: Speed Control 1: Torque Control	0	○
Fb.11	Setting Source of Torque in Torque Control Mode	0: Digital setting (Fb.12) 1: AI1 2: AI2 3: AI3 4: Pulse Setting (DI5) 5: Communication Setting 6: MIN (AI1, AI2) 7: MAX (AI1, AI2) (Full range of values 1-7 corresponds to the digital setting of Fb.12).	0	○
Fb.12	Digital Setting of Torque in Torque Control Mode	-200.0%~200.0%	150.0%	●
Fb.13	Forward Maximum Frequency in Torque Control Mode	0.00Hz to Maximum Frequency	50.00Hz	●
Fb.14	Reverse Maximum Frequency in Torque Control	0.00Hz to Maximum Frequency	50.00Hz	●
Fb.15	Acceleration Time in Torque Control Mode	0.00s~65000s	0.00s	●
Fb.16	Deceleration Time in Torque Control Mode	0.00s~65000s	0.00s	●
<b>Group FC: Multi-Reference and Simple PLC Function</b>				
FC.00	Command 0	-100.0%~100.0%	0.0%	●
FC.01	Command 1	-100.0%~100.0%	0.0%	●

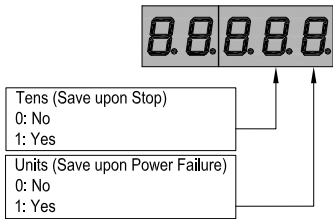
Function Codes	Parameter Name	Range of Settings	Default	Property
FC.02	Command 2	-100.0%~100.0%	0.0%	●
FC.03	Command 3	-100.0%~100.0%	0.0%	●
FC.04	Command 4	-100.0%~100.0%	0.0%	●
FC.05	Command 5	-100.0%~100.0%	0.0%	●
FC.06	Command 6	-100.0%~100.0%	0.0%	●
FC.07	Command 7	-100.0%~100.0%	0.0%	●
FC.08	Command 8	-100.0%~100.0%	0.0%	●
FC.09	Command 9	-100.0%~100.0%	0.0%	●
FC.10	Command10	-100.0%~100.0%	0.0%	●
FC.11	Command11	-100.0%~100.0%	0.0%	●
FC.12	Command12	-100.0%~100.0%	0.0%	●
FC.13	Command13	-100.0%~100.0%	0.0%	●
FC.14	Command14	-100.0%~100.0%	0.0%	●
FC.15	Command15	-100.0%~100.0%	0.0%	●
FC.16	Simple PLC Operation Mode	0: Stop after one cycle 1: Keep the final values after one cycle 2: Repeat	0	●
FC.17	Simple PLC Saving Options	 <p>Tens (Save upon Stop) 0: No 1: Yes</p> <p>Units (Save upon Power Failure) 0: No 1: Yes</p>	00	●
FC.18	Operating Time of Simple PLC Command 0	0.0s(h)~6500.0s(h)	0.0s (h)	●
FC.19	Acceleration / Deceleration Time of Simple PLC Command 0	0~3	0	●
FC.20	Operating Time of Simple PLC Command 1	0.0s(h)~6500.0s(h)	0.0s (h)	●
FC.21	Acceleration / Deceleration Time of Simple PLC Command 1	0~3	0	●
FC.22	Operating Time of Simple PLC Command 2	0.0s(h)~6500.0s(h)	0.0s (h)	●
FC.23	Acceleration / Deceleration Time of Simple PLC Command 2	0~3	0	●

Function Codes	Parameter Name	Range of Settings	Default	Property
FC.24	Operating Time of Simple PLC Command 3	0.0s(h)~6500.0s(h)	0.0s (h)	●
FC.25	Acceleration / Deceleration Time of Simple PLC Command 3	0~3	0	●
FC.26	Operating Time of Simple PLC Command 4	0.0s(h)~6500.0s(h)	0.0s (h)	●
FC.27	Acceleration / Deceleration Time of Simple PLC Command 4	0~3	0	●
FC.28	Operating Time of Simple PLC Command 5	0.0s(h)~6500.0s(h)	0.0s (h)	●
FC.29	Acceleration / Deceleration Time of Simple PLC Command 5	0~3	0	●
FC.30	Operating Time of Simple PLC Command 6	0.0s(h)~6500.0s(h)	0.0s (h)	●
FC.31	Acceleration / Deceleration Time of Simple PLC Command 6	0~3	0	●
FC.32	Operating Time of Simple PLC Command 7	0.0s(h)~6500.0s(h)	0.0s (h)	●
FC.33	Acceleration / Deceleration Time of Simple PLC Command 7	0~3	0	●
FC.34	Operating Time of Simple PLC Command 8	0.0s(h)~6500.0s(h)	0.0s (h)	●
FC.35	Acceleration / Deceleration Time of Simple PLC Command 8	0~3	0	●
FC.36	Operating Time of Simple PLC Command 9	0.0s(h)~6500.0s(h)	0.0s (h)	●
FC.37	Acceleration / Deceleration Time of Simple PLC Command 9	0~3	0	●
FC.38	Operating Time of Simple PLC Command 10	0.0s(h)~6500.0s(h)	0.0s (h)	●
FC.39	Acceleration / Deceleration Time of Simple PLC Command 10	0~3	0	●
FC.40	Operating Time of Simple PLC Command 11	0.0s (h) ~6500.0s (h)	0.0s (h)	●
FC.41	Acceleration / Deceleration Time of Simple PLC Command 11	0~3	0	●
FC.42	Operating Time of Simple PLC Command 12	0.0s (h) ~6500.0s (h)	0.0s (h)	●
FC.43	Acceleration / Deceleration Time of Simple PLC Command 12	0~3	0	●
FC.44	Operating Time of Simple PLC Command 13	0.0s (h) ~6500.0s (h)	0.0s (h)	●

Function Codes	Parameter Name	Range of Settings	Default	Property
FC.45	Acceleration / Deceleration Time of Simple PLC Command 13	0~3	0	●
FC.46	Operating Time of Simple PLC Command 14	0.0s (h) ~6500.0s (h)	0.0s (h)	●
FC.47	Acceleration / Deceleration Time of Simple PLC Command 14	0~3	0	●
FC.48	Operating Time of Simple PLC Command 15	0.0s (h) ~6500.0s (h)	0.0s (h)	●
FC.49	Acceleration / Deceleration Time of Simple PLC Command 15	0~3	0	●
FC.50	Time unit of simple PLC running	0: s 1: h	0	●
FC.51	Reference 0 source	1: AI1 2: AI2 3: AI3 4: Pulse setting 5: PID 6: Set by preset frequency (F0.08), modified via terminal UP/DOWN	0	●
Group Fd: Communication Parameters				
Function Codes	Parameter Name	Range of Settings	Default	Property
Fd.00	Baud Rate	0: 300BPS 1: 600BPS 2: 1200BPS 3: 2400BPS 4: 4800BPS 5: 9600BPS 6: 19200BPS 7: 38400BPS	5	●
Fd.01	Data Format	0: No Check, Data Format <8,N,2> 1: Even Parity Check, Data Format <8,E,1> 2: Upper Limit, Data Format <8,N,1>	0	●
Fd.02	Local Address	1~247 0: Broadcast Address	1	●
Fd.03	Response Delay	0ms~20ms	2	●
Fd.04	Communication Timeout	0.0(Invalid), 0.1s~60.0s	0.0	●
Fd.05	Modbus Protocol Selection Data Format	Units: MODBUS 0: Non-Standard Modbus Protocol 1: Standard Modbus Protocol	1	●
Fd.06	Current Resolution of Communication Reading	0: 0.01A    1: 0.1A	0	●

Group FE: Quick Menu Parameters				
Function Codes	Parameter Name	Range of Settings	Default	Property
FE.00	Quick Menu 0	F0.00~FF.xx P0.00~P1.xx H0.00~H0.xx	F0.01	●
FE.01	Quick Menu 1		F0.02	●
FE.02	Quick Menu 2		F0.03	●
FE.03	Quick Menu 3		F0.07	●
FE.04	Quick Menu 4		F0.08	●
FE.05	Quick Menu 5		F0.17	●
FE.06	Quick Menu 6		F0.18	●
FE.07	Quick Menu 7		F3.00	●
FE.08	Quick Menu8		F3.01	●
FE.09	Quick Menu 9		F4.00	●
FE.10	Quick Menu 10		F4.01	●
FE.11	Quick Menu 11		F4.02	●
FE.12	Quick Menu 12		F5.04	●
FE.13	Quick Menu 13		F5.07	●
FE.14	Quick Menu 14		F6.00	●
FE.15	Quick Menu 15		F6.10	●
FE.16	Quick Menu 16		F0.00	●
FE.17	Quick Menu 17		F0.00	●
FE.18	Quick Menu 18		F0.00	●
FE.19	Quick Menu 19		F0.00	●
FE.20	Quick Menu 20		F0.00	●
FE.21	Quick Menu 21		F0.00	●
FE.22	Quick Menu 22		F0.00	●
FE.23	Quick Menu 23		F0.00	●
FE.24	Quick Menu 24		F0.00	●
FE.25	Quick Menu 25		F0.00	●
FE.26	Quick Menu 26		F0.00	●
FE.27	Quick Menu 27		F0.00	●
FE.28	Quick Menu 28		F0.00	●
FE.29	Quick Menu 29	F0.00	●	
Group P0: Analog Four-Point Offset Parameters				
Function Codes	Parameter Name	Range of Settings	Default	Property
P0.00	AI Curve 4 Minimum Input	-10.00V~P0.02	0.00V	●
P0.01	Corresponding Setting of AI Curve 4 Minimum Input	-100.0%~+100.0%	0.0%	●
P0.02	AI Curve 4 Inflection Point 1 Input	P0.00~P0.04	3.00V	●

Function Codes	Parameter Name	Range of Settings	Default	Property
P0.03	Corresponding Setting of AI Curve 4 Inflection Point 1 Input	-100.0%~+100.0%	30.0%	●
P0.04	AI Curve 4 Inflection Point 2 Input	P0.02~P0.06	6.00V	●
P0.05	Corresponding Setting of AI Curve 4 Inflection Point 2 Input	-100.0%~+100.0%	60.0%	●
P0.06	AI Curve 4 Maximum Input	P0.04~+10.00V	10.00V	●
P0.07	Corresponding Setting of AI curve 4 Maximum Input	-100.0%~+100.0%	100.0%	●
P0.08	AI curve 5 Minimum Input	-10.00V~P0.10	-10.00V	●
P0.09	Corresponding Setting of AI Curve 5 Minimum Input	-100.0%~+100.0%	-100.0%	●
P0.10	AI Curve 5 Inflection Point 1 Input	P0.08~P0.12	-3.00V	●
P0.11	Corresponding Setting of AI Curve 5 Inflection Point 1 Input	-100.0%~+100.0%	-30.0%	●
P0.12	AI Curve 5 Inflection Point 2 Input	P0.10~P0.14	3.00V	●
P0.13	Corresponding Setting of AI Curve 5 Inflection Point 2 input	-100.0%~+100.0%	30.0%	●
P0.14	AI Curve 5 Maximum Input	P0.12~+10.00V	10.00V	●
P0.15	Corresponding Setting of AI Curve 5 Maximum Input	-100.0%~+100.0%	100.0%	●
P0.24	Jump Point of AI1 Input Setting	-100.0%~100.0%	0.0%	●
P0.25	Jump Amplitude of AI1 Input Setting	0.0%~100.0%	0.5%	●
P0.26	Jump Point of AI2 Input Setting	-100.0%~100.0%	0.0%	●
P0.27	Jump Amplitude of AI2 Input Setting	0.0%~100.0%	0.5%	●
P0.28	Jump Point of AI3 Input Setting	-100.0%~100.0%	0.0%	●
P0.29	Jump Amplitude of AI3 Input Setting	0.0%~100.0%	0.5%	●
Group P1: AI/AO Correction Parameters				
P1.00	AI1 Measured Voltage 1	0.500V~4.000V	Factory Corrected	●
P1.01	AI1 Displayed Voltage 1	0.500V~4.000V	Factory Corrected	●
P1.02	AI1 Measured Voltage 2	6.000V~9.999V	Factory Corrected	●
P1.03	AI1 Displayed Voltage 2	6.000V~9.999V	Factory Corrected	●



Function Codes	Parameter Name	Range of Settings	Default	Property
P1.04	AI2 Measured Voltage 1	0.000V~5.000V	Factory Corrected	●
P1.05	AI2 Displayed Voltage 1	0.000V~5.000V	Factory Corrected	●
P1.06	AI2 Measured Voltage 2	5.000V~10.000V	Factory Corrected	●
P1.07	AI2 Displayed Voltage 2	5.000V~10.000V	Factory Corrected	●
P1.08	AI3 Measured Voltage 1	0.000V~5.000V	Factory Corrected	●
P1.09	AI3 Displayed Voltage 1	0.000V~5.000V	Factory Corrected	●
P1.10	AI3 Measured Voltage 2	5.000V~10.000V	Factory Corrected	●
P1.11	AI3 Displayed Voltage 2	5.000V~10.000V	Factory Corrected	●
P1.12	AO1 Target Voltage 1	0.000V~5.000V	Factory	●
P1.13	AO1 Measured Voltage 1	0.000V~5.000V	Factory Corrected	●
P1.14	AO1 Target Voltage 2	5.000V~10.000V	Factory Corrected	●
P1.15	AO1 Measured Voltage 2	5.000V~10.000V	Factory Corrected	●
P1.16	AO2 Target Voltage 1	0.000V~5.000V	Factory Corrected	●
P1.17	AO2 Measured Voltage 1	0.000V~5.000V	Factory Corrected	●
P1.18	AO2 Target Voltage 2	5.000V~10.000V	Factory Corrected	●
P1.19	AO2 Measured Voltage 2	5.000V~10.000V	Factory Corrected	●
P1.20	AI1 Filtering Dead Zone	0~255	0	●
P1.21	AI2 Filtering Dead Zone	0~255	0	●
P1.22	AI3 Filtering Dead Zone	0~255	66	●

Function Code	Parameter Name	Minimum Unit
Group H0: Standard Monitoring Parameters		
H0.00	Operating Frequency (Hz)	0.01Hz
H0.01	Set Frequency (Hz)	0.01Hz
H0.02	Output Current(A)	0.01A
H0.03	Output Voltage (V)	1V
H0.04	Output Power (kW)	0.1kW
H0.05	Output Torque (%)	0.1%
H0.06	Bus Voltage (V)	0.1V
H0.07	X Input Status1	1
H0.08	X Input Status 2	1
H0.09	DO Output State	1
H0.10	AI1 Voltage (V)	0.01V
H0.11	AI2 Voltage (V)	0.01V
H0.12	AI3 Voltage (V)	0.01V
H0.13	Input Pulse Frequency (kHz)	0.01kHz
H0.14	PID Setting	1
H0.15	PID Feedback	1
H0.16	PID Output	1
H0.17	Load Speed	1
H0.18	Main Frequency	0.01Hz
H0.19	Auxiliary Frequency	0.01Hz
H0.20	Feedback Speed	0.1Hz
H0.21	Count Value	1
H0.22	Length Value	1
H0.23	Linear Speed	1m/Min
H0.24	Accumulated Power-On Time	1Min
H0.25	Accumulated Operating Time	0.1Min
H0.26	Motor Overload Count	0.1%
H0.27	Motor Current Percentage	0.1%
H0.28	Remaining Operating Time	0.1Min
H0.29	PLC Phase	1
H0.30	Communication Setting Value	0.01%
H0.31	AI1 Voltage Before Correction	0.01V
H0.32	AI2 Voltage Before correction	0.01V
H0.33	AI3 Voltage Before Correction	0.01V
H0.34	Inverter Overload Count	0.1%
H0.35	Inverter Current Percentage	0.1%

## Chapter 7 Description of Parameters

### Group F0: Basic Function

F0.00	G/P type	Range:1~2	Default:1
-------	----------	-----------	-----------

- 1: G type (constant torque load)
- 2: P type (variable torque load e.g. Fan and pump)

F0.01	Motor control mode	Range:0~2	Default:2
-------	--------------------	-----------	-----------

0: Sensorless flux vector control (SFVC)

It indicates open-loop vector control, and is applicable to high-performance control applications such as machine tool, centrifuge, wire drawing machine and injection moulding machine. One inverter can operate only one motor.

1: Closed-loop vector control (CLVC)

It is applicable to high-accuracy speed control or torque control applications such as high-speed paper making machine, crane and elevator. One inverter can operate only one motor. An encoder must be installed at the motor side, and a PG card matching the encoder must be installed at the inverter side.

2: Voltage/Frequency (V/F) control

It is applicable to applications with low load requirements or applications where one inverter operates multiple motors, such as fan and pump.

F0.02	Command source options	Range:0~2	Default:0
-------	------------------------	-----------	-----------

0: Operation panel control

Commands are given by pressing keys “RUN,STOP”on the operation panel.

1: Terminal control

Commands are given by means of multifunctional input terminals with functions such as “FWD, REV, JOGF, and JOGR”.

2: Communication control

Commands are given from host computer.

F0.03	Main frequency(X) source selection	Range:0~13	Default:4
-------	------------------------------------	------------	-----------

0: Digital setting (non-retentive at power failure)

The initial value of the set frequency is the value of F0.08 (Preset frequency). You can change the set frequency by pressing  $\Delta$  V on the operation panel (or using the UP/DOWN function of input terminals).

When the inverter is powered on again after power failure, the set frequency reverts to the value of F0.08.

1: Digital setting (retentive at power failure)

Basic operations are the same as "0: Digital setting" .

The only difference is that when the inverter is powered on again after power failure, the set frequency is the value memorized at the moment of the last power failure.

Note: The hidden parameters set down by F0.20 cleared or unclear 0, factory default is cleared down.

2: AI1 (0–10 V voltage input)

3: AI2 (0–10 V voltage input or 4–20 mA current input, determined by jumper )

4: AI3 (0–10 V voltage input)

The frequency is set by analog input.

5: Pulse setting (X5)

The frequency is set by X5 (high-speed pulse). The signal specification of pulse setting is 9–30 V (voltage range) and 0–100 kHz (frequency range). The corresponding value100% of pulse setting corresponds to the value of F0.10 (Maximum frequency).

6: Multi-reference

In multi-reference mode, combinations of different X terminal states correspond to different set frequencies. The AT550 supports a maximum of 16 speeds implemented by 16 state combinations of four X terminals (allocated with functions 12 to 15)in Group FC. The multiple references indicate percentages of the value of F0.10(Maximum frequency).

If X terminal is used for the multi-reference function, you need to perform related setting in group F2 7: Simple PLC

When the simple programmable logic controller (PLC) mode is used as the frequency source, the running frequency of the inverter can be switched over among the 16 frequency references. You can set the holding time and acceleration/deceleration time of the 16 frequency references. For details, refer to the descriptions of Group FC.

8: PID

The output of PID control is used as the running frequency. PID control is generally used in on-site closed-loop control, such as constant pressure closed-loop control and constant tension closed-loop control. When applying PID as the frequency source, you need to set parameters of PID function in group FA.

9: Communication setting

The frequency is set by means of communication. In other conditions, data is given by the host computer through the communication address 0x1000. The data format is -100.00% to 100.00%. 100.00% corresponds to the value of F0.10 (Maximum frequency).

10: A11+A12

11: A11-A12

12: max(A11, A12)

13: min(A11, A12)

F0.04	Auxiliary frequency(Y) given ways	Range:0~9	Default:0
-------	-----------------------------------	-----------	-----------

When used as an independent frequency input channel (frequency source switched over from X to Y), the auxiliary frequency source Y is used in the same way as the main frequency source X (refer to F0.03).

When the auxiliary frequency source is used for operation (frequency source is "X and Y operation"), pay attention to the following aspects:

- 1) If the auxiliary frequency source Y is digital setting, the preset frequency (F0.08) does not take effect. You can directly adjust the set main frequency by pressing keys  $\Delta$ 、 $\nabla$  on the operation panel (or using the UP/DOWN function of input terminals).
- 2) If the auxiliary frequency source is analog input (A11, A12 and A13) or pulse setting, 100% of the input corresponds to the range of the auxiliary frequency Y (set in F0.05 and F0.06).
- 3) If the auxiliary frequency source is pulse setting, it is similar to analog input.

The main frequency source X and auxiliary frequency source Y must not use the same channel. That is, F0.03 and F0.04 cannot be set to the same value.

F0.05	Auxiliary speed range selection	Range:0~1	Default:0
F0.06	Auxiliary speed range	Range:0~150	Default:100%

If X and Y operation is used, F0.05 and F0.06 are used to set the adjustment range of the auxiliary frequency source. You can set the auxiliary frequency to be relative to either maximum frequency or main frequency X. If relative to main frequency X, the setting range of the auxiliary frequency Y varies according to the main frequency X.

F0.07	Frequency source selection	Range:0~34	Default:0
Ten's digit	Unit's digit		
0: X+Y 1: X-Y 2: Maximum 3: Minimum	0: Main frequency source 1: Main frequency (X) and auxiliary frequency(Y) operation (operation relationship determined by ten's digit) 2: Switch over between main frequency and auxiliary frequency 3: Switch over between main frequency and "main frequency and auxiliary frequency operation" 4: Switch over between auxiliary frequency and "main frequency and auxiliary frequency operation"		

It is used to select the frequency setting channel. If the frequency source involves X and Y operation, you can set the frequency offset in F0.21 for superposition to the X and Y operation result, flexibly satisfying various requirements.

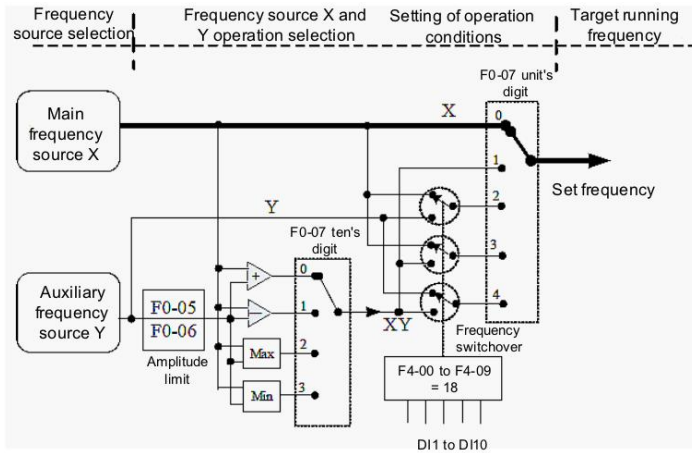

Figure 7.1 Frequency setting

F0.08	Digital frequency	Range:0.00Hz~max.freq	Default:50.00Hz
-------	-------------------	-----------------------	-----------------

If the frequency source is digital setting or terminal UP/DOWN, the value of this parameter is the initial frequency of the inverter (digital setting).

F0.09	Rotation direction	Range:0~1	Default:0
-------	--------------------	-----------	-----------

- 0: Same direction
- 1: Reverse direction

You can change the rotation direction of the motor just by modifying this parameter without changing the motor wiring. Modifying this parameter is equivalent to exchanging any two of the motor's U, V, W wires.

F0.10	Maximum frequency	Range:50.00Hz~320.00Hz	Default:50.00Hz
-------	-------------------	------------------------	-----------------

When the frequency source is AI, pulse setting (X5), or multi-reference, 100% of the input corresponds to the value of this parameter.

F0.11	Source of frequency upper limit	Range:0~5	Default:0
-------	---------------------------------	-----------	-----------

It is used to set the source of the frequency upper limit, including digital setting (F0.12), AI, pulse setting or communication setting. If the frequency upper limit is set by means of AI1, AI2, AI3, DI5 or communication, the setting is similar to that of the main frequency source X. For details, see the description of F0.03.

F0.12	Frequency upper limit	Range:lower limit(F0.14)~max.freq (F0.10)	Default:50.00Hz
-------	-----------------------	---	-----------------

This parameter is used to set the frequency upper limit.

F0.13	Frequency upper limit offset	Range:0.00~maximum frequency	Default:0.00 Hz
-------	------------------------------	------------------------------	-----------------

If the source of the frequency upper limit is analog input or pulse setting, the final frequency upper limit is obtained by adding the offset in this parameter to the frequency upper limit set in F0.11.

F0.14	Frequency lower limit	Range:0.00~frequency upper limit	Default:0.00 Hz
-------	-----------------------	----------------------------------	-----------------

If the frequency reference is lower than the value of this parameter, the inverter can stop, run at the frequency lower limit, or run at zero speed, determined by F4.14.

F0.15	Carrier frequency	Range:0.5kHz~16.0kHz	Default:Model Dependent
-------	-------------------	----------------------	-------------------------

It is used to adjust the carrier frequency of the inverter, helping to reduce the motor noise, avoiding the resonance of the mechanical system, and reducing the leakage current to the earth and interference generated by the inverter.

If the carrier frequency is low, output current has high harmonics, and the power loss and temperature rise of the motor increase.

If the carrier frequency is high, power loss and temperature rise of the motor declines. However, the inverter has an increase in power loss, temperature rise and interference.

Adjusting the carrier frequency will exert influences on the aspects listed in the following table.

Carrier frequency	Low	High
Motor noise	Large	Small
Output current waveform	Bad	Good
Motor temperature rise	High	Low
AC drive temperature rise	Low	High
Leakage current	Small	Large
External radiation interference	Small	Large

The factory setting of carrier frequency varies with the inverter power. If you need to modify the carrier frequency, note that if the set carrier frequency is higher than factory setting, it will lead to an increase in temperature rise of the inverter's heatsink. In this case, you need to de-rate the inverter. Otherwise, the inverter may overheat and alarm.

F0.16	Carrier frequency adjustment with temperature	Range:0~1	Default:1
-------	---	-----------	-----------

0: No

1: Yes

It is used to set whether the carrier frequency is adjusted based on the temperature. The inverter automatically reduces the carrier frequency when detecting that the heatsink temperature is high. The inverter resumes the carrier frequency to the set value when the heatsink temperature becomes normal. This function reduces the overheat alarms.

F0.17	Acceleration time 1	Range:0.0s~6500.0s	Default:Model Dependent
F0.18	Deceleration time 1	Range:0.0s~6500.0s	Default:Model Dependent

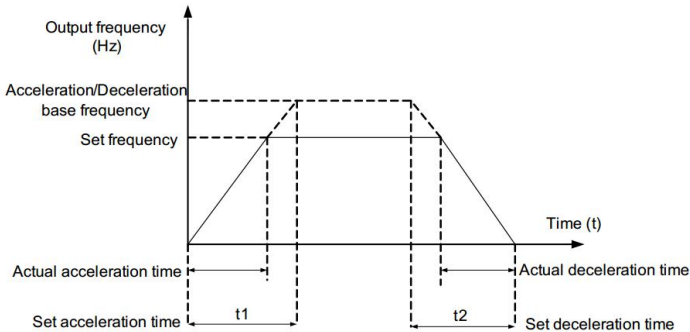

The AT550 provides totally four groups of acceleration/deceleration time for selection. You can perform switchover by using a X terminal.

- Group 1: F0.17, F0.18
- Group 2: F4.03, F4.04
- Group 3: F4.05, F4.06
- Group 4: F4.07, F4.08

F0.19	Frequency offset of auxiliary frequency source for X and Y operation	Range:0.00Hz~maximum frequency		Default:0.00Hz
F0.20	Digital set frequency attribute selection	Range:0~1		Default:0
Thousand's digit		Hundred's digit	Ten's digit	Units' digit
terminal UP/DN rate 0: frequency rate.F2.12 is rate, the unit for Hz/s 1: integral rate.F2.12 is time, the unit is "s", F2.12 only one decimal of F2.12 IS effectively, the last two are ignored.		when stop the UP/DN effective choice 0: Valid 1: Invalid	the UP/DN and reversing choice when analog superposition 0: can the reversing 1: not the reversing	stop memory options 0: no. 1: memory
F0.21	Acceleration/Deceleration time base frequency	Range:0~2		Default:0

- 0: Maximum frequency (F0.10)
- 1: Set frequency
- 2: 100 Hz

The acceleration/deceleration time indicates the time for the inverter to increase from 0 Hz to the frequency set in F0.21. If this parameter is set to 1, the acceleration/deceleration time is related to the set frequency. If the set frequency changes frequently, the motor's acceleration/deceleration also changes.

F0.22	Base frequency for UP/DOWN	Range:0~1	Default:0
-------	----------------------------	-----------	-----------

- 0: Running frequency
- 1: Set frequency

This parameter is valid only when the frequency source is digital setting.It is used to set the base frequency to be modified by using keys and or the terminal UP/DOWN function. If the running frequency and set frequency are different, there will be a large difference between the inverter's performance during the acceleration/deceleration process.

F0.23	User password	Range:0~65536	Default:0
-------	---------------	---------------	-----------

If it is set to any non-zero number, the password protection function is enabled. After a password has been set and taken effect, you must enter the correct password in order to enter the menu. If the entered password is incorrect you cannot view or modify parameters.

If F0.23 is set to 00000, the previously set user password is cleared, and the password function is disabled.

F0.24	Restore default settings	Range:0~501	Default:0
-------	--------------------------	-------------	-----------

- 1: Restore default settings except motor parameters

If F0.24 is set to 1, most function codes are restored to the default settings except motor parameters, frequency reference resolution, fault records, accumulative running time, accumulative power-on time and accumulative power consumption .

- 2: Clear records

If F0.24 is set to 2, the fault records, accumulative running time , accumulative power-on time and accumulative power consumption are cleared.

F0.25	Individualized parameter display property	Range:0~11	Default:00
-------	---	------------	------------

The setting of parameter display mode aims to facilitate you to view different types of parameters based on actual requirements. The AT550 provides the following three parameter display modes.

Unit's digit: User-defined parameter display selection.This mode displays only the parameters user needs. Up to 30 parameters set by the FE group.

Ten's digit: Non-factory value menu, and the user to modify the parameters, this mode displays only the user modified parameters.

Ten's digit	Unit's digit
0: Not display	0: Not display
1: Display	1: Display

Menu mode switch over by MK.

F0.26	Parameter modification property	Range:0~1	Default:0
-------	---------------------------------	-----------	-----------

0: Modifiable

1: Not modifiable

It is used to set whether the parameters are modifiable to avoid mal-function. If it is set to 0, all parameters are modifiable. If it is set to 1, all parameters can only be viewed.

## Group F1: Motor parameters

F1.00	Motor model	Range:0~1	Default:0
-------	-------------	-----------	-----------

0: Common asynchronous motor

1: Variable frequency asynchronous motor

F1.01	Motor rated power	Range:0.1kW~1000.0kW	Default: Model dependent
F1.02	Motor rated voltage	Range:1V~2000V	Default: Model dependent
F1.03	Motor rated current	Range: 0.01A~655.35A(≤55kW) 0.1A~6553.5A (>55kW)	Default: Model dependent
F1.04	Motor rated frequency	Range:0.01Hz~maximum frequency	Default: Model dependent
F1.05	Motor nominal speed	Range:1rpm~65535rpm	Default: Model dependent
F1.06	Motor stator resistance	Range: 0.001Ω~65.535Ω(≤55kW) 0.0001Ω~6.5535Ω(>55kW)	Default: Model dependent
F1.07	Rotor resistance	Range: 0.001Ω~65.535Ω(≤55kW) 0.0001Ω~6.5535Ω(>55kW)	Default: Model dependent
F1.08	Leakage inductive reactance	Range: 0.01mH~655.35mH(≤55kW) 0.001mH~65.535mH(>55kW)	Default: Model dependent
F1.09	Mutual inductive reactance	Range: 0.1mH~6553.5mH(≤55kW) 0.01mH~655.35mH(>55kW)	Default: Model dependent
F1.10	No-load current	Range: 0.01A~655.35A(≤55kW) 0.1A~6553.5A (>55kW)	Default: Model dependent

After the end of normal motor parameter identification, setting F1.06 ~ F1.10 will be updated. Change the motor rated power (F1.01) or motor rated voltage (F1.02), the drive will F1.06 ~ F1.10 parameter is set to the default standard motor parameters.

F1.27	Encoder pulses per revolution	Range:0~65535	Default:0
-------	-------------------------------	---------------	-----------

This parameter is used to set the pulses per revolution (PPR) of ABZ or UVW incremental encoder. In CLVC mode, the motor cannot run properly if this parameter is set incorrectly.

F1.30	A/B phase sequence of ABZ incremental encoder	Range:0~1	Default:0
-------	---	-----------	-----------

It is valid for both asynchronous motor and synchronous motor. The A/B phase sequence can be obtained through "Asynchronous motor complete auto-tuning" or "Synchronous motor no-load auto-tuning".

F1.37	The parameters self-identification	Range:0~2	Default:0
-------	------------------------------------	-----------	-----------

0: No operation, which prohibits self-identification parameters

1: static self identification, suitable for induction motor and the load is not easy to disengage, but not a complete self-identification of the occasion



Asynchronous machine standstill since the previous identification, you must set the correct motor type and motor nameplate parameters F1.00 ~ F1.05. Stationary self-identification, the drive can get F1.06 ~ F1.08 three parameters.

Action Description: Set the function code is 1, then press the RUN key, the drive will still self-identify.

2: complete self-identification

To ensure the dynamic control performance of the inverter, please choose the complete self-identification, and the motor must be separated from the load to keep the motor for the no-load condition. Complete self-identification process, the inverter will be stationary self identification, and then follow the acceleration time to accelerate to 80% F0.17 rated motor frequency, after a period of time, according to the deceleration time F0.18 deceleration stop and end self identification.

Asynchronous machine complete self-identification, the drive can get F1.06 ~ F1.10 five motor parameters, and the encoder AB phase sequence F1.30, vector control current loop PI parameters F5.13 ~ F5.16.

Action Description: Set the function code is 2, then press the RUN key, the drive will be a complete self-identification.

## Group F2:Input Terminal

AT550 series inverter have five multi-function input terminals X1 ~ X5 (X5 which can be used as high-speed pulse input), two analog input terminal AI1, AI2 (which can be used as a voltage input AI2, but also as a current input), a keyboard potentiometer.

F2.00	X1 function selection	Range:0~50	Default: 1
F2.01	X2 function selection	Range:0~50	Default:4
F2.02	X3 function selection	Range:0~50	Default:9
F2.03	X4 function selection	Range:0~50	Default:12
F2.04	X5 function selection	Range:0~50	Default:13
F2.05	X6 function selection	Range:0~50	Default:0
F2.06	X7 function selection	Range:0~50	Default:0
F2.07	X8 function selection	Range:0~50	Default:0
F2.08	X9 function selection	Range:0~50	Default:0
F2.09	X10 function selection	Range:0~50	Default:0

Input Terminal Setting list:

value	Function	Description
0	No function	
1	Forward RUN (FWD)	The terminal is used to control forward or reverse RUN of the inverter.
2	Reverse RUN (REV)	
3	Three-line control	The terminal determines three-line control of the inverter. For details, see the description of F2.11.
4	Forward JOG (FJOG)	FJOG indicates forward JOG running, while RJOG indicates reverse JOG running. The JOG frequency,acceleration time and deceleration time are described respectively in F4.00,F4.01,F4.02.
5	Reverse JOG (RJOG)	
6	Terminal UP	If the frequency is determined by external terminals, the terminals with the two functions are used as increment and decrement commands for frequency modification. When the frequency source is digital setting, they are used to adjust the frequency.
7	Terminal DOWN	
8	Coast to stop	The inverter blocks its output, the motor coasts to rest and is not controlled by the inverter.

9	Fault reset (RESET)	The terminal is used for fault reset function, the same as the function of RESET key on the operation panel.
10	RUN pause	The inverter decelerates to stop, but the running parameters are all memorized, such as PLC, swing frequency and PID parameters. After this function is disabled, the inverter resumes its status before stop.
11	Normally open (NO) input of external fault	If this terminal becomes ON, the inverter reports Err15 and performs the fault protection action. For more details, see the description of F9.47.
12	Multi-reference terminal 1	The setting of 16 speeds or 16 other references can be implemented through combinations of 16 states of these four terminals.
13	Multi-reference terminal 2	
14	Multi-reference terminal 3	
15	Multi-reference terminal 4	
16	Terminal 1 for acceleration/deceleration time selection	Totally four groups of acceleration/deceleration time can be selected through combinations of two states of these two terminals.
17	Terminal 2 for acceleration/deceleration time selection	
18	Frequency source switch over	The terminal is used to perform switchover between two frequency sources according to the setting in F0.07
19	UP and DOWN setting clear (terminal, operation panel)	If the frequency source is digital setting, the terminal is used to clear the modification by using the UP/DOWN function or the increment/decrement key on the operation panel, returning the set frequency to the value of F0.08.
20	Command source switch over keyboard	If the command source is set to terminal control (F0.02= 1), this terminal is used to perform switchover between terminal control and operation panel control. If the command source is set to communication control (F0.02 = 2), this terminal is used to perform switchover between communication control and operation panel control.
21	Acceleration/Deceleration prohibited	It enables the inverter to maintain the current frequency output without being affected by external signals (except the STOP command).
22	PID pause	PID is invalid temporarily. The inverter maintains the current frequency output without supporting PID adjustment of frequency source.
23	PLC status reset	The terminal is used to restore the original status of PLC control for the inverter when PLC control is started again after a pause
24	Swing pause	The inverter outputs the central frequency, and the swing frequency function pauses
25	Counter input	This terminal is used to count pulses
26	Counter reset	This terminal is used to clear the counter status.
27	Length count input	This terminal is used to count the length
28	Length reset	This terminal is used to clear the length
29	Torque control prohibited	The inverter is prohibited from torque control and enters the speed control mode.
30	Pulse input (only for X5)	X5 is used for pulse input.

32	Immediate DC braking	After this terminal becomes ON, the inverter directly switches over to the DC braking state.
33	Normally closed (NC) input of external fault	After this terminal becomes ON, the inverter reports Err15 and stops.
34	Frequency modification forbidden	After this terminal becomes ON, the inverter does not respond to any frequency modification.
35	Reverse PID action direction	After this terminal becomes ON, the PID action direction is reversed to the direction set in FA.03.
36	External STOP terminal 1	In operation panel mode, this terminal can be used to stop the inverter, equivalent to the function of the STOP key on the operation panel.
37	Command source switch over terminal	It is used to perform switchover between terminal control and communication control. If the command source is terminal control, the system will switch over to communication control after this terminal becomes ON.
38	PID integral pause	After this terminal becomes ON, the integral adjustment function pauses. However, the proportional and differentiation adjustment functions are still valid.
39	Switch over between main frequency source X and digital Frequency	After this terminal becomes ON, the frequency source X is replaced by the preset frequency set in F0.08.
40	Switch over between auxiliary frequency source Y and digital frequency	After this terminal is enabled, the frequency source Y is replaced by the preset frequency set in F0.08
41	Switch over between PID parameters	If the PID parameters switchover performed by means of DI terminal (FA.18 = 1), the PID parameters are FA.05 to FA.07 when the terminal becomes OFF; the PID parameters are FA.15 to FA.17 when this terminal becomes ON.
42	User-defined fault 1	If these two terminals become ON, the inverter reports Err27 and Err28 respectively, and performs fault protection actions based on the setting in F9.49.
43	User-defined fault 2	
44	Speed control/Torque control switchover	This terminal enables the inverter to switch over between speed control and torque control. When this terminal becomes OFF, the inverter runs in the mode set in Fb.10. When this terminal becomes ON, the inverter switches over to the other control mode.
45	Emergency stop	When this terminal becomes ON, the inverter stops within the shortest time. During the stop process, the current remains at the set current upper limit. This function is used to satisfy the requirement of stopping the inverter in emergency state.
46	External STOP terminal 2	In any control mode, it can be used to make the inverter decelerate to stop. In this case, the deceleration time is deceleration time 4.
47	Deceleration DC braking	When this terminal becomes ON, the inverter decelerates to the initial frequency of stop DC braking and then switches over to DC braking state.
48	Clear the current running time	When this terminal becomes ON, the inverter's current running time is cleared. This function must be supported by F4.42 and F4.53

Table 7-1 Input Terminal Setting list

Multi-reference Setting					
multi-reference terminal 4	Multi-reference terminal 3	Multi-reference terminal 2	Multi-reference terminal 1	Frequency setting	Corresponding parameter
OFF	OFF	OFF	OFF	Reference 0	FC.51
OFF	OFF	OFF	ON	Reference 1	FC.01
OFF	OFF	ON	OFF	Reference 2	FC.02
OFF	OFF	ON	ON	Reference 3	FC.03
OFF	ON	OFF	OFF	Reference 4	FC.04
OFF	ON	OFF	ON	Reference 5	FC.05
OFF	ON	ON	OFF	Reference 6	FC.06
OFF	ON	ON	ON	Reference 7	FC.07
ON	OFF	OFF	OFF	Reference 8	FC.08
ON	OFF	OFF	ON	Reference 9	FC.09
ON	OFF	ON	OFF	Reference 10	FC.10
ON	OFF	ON	ON	Reference 11	FC.11
ON	ON	OFF	OFF	Reference 12	FC.12
ON	ON	OFF	ON	Reference 13	FC.13
ON	ON	ON	OFF	Reference 14	FC.14
ON	ON	ON	ON	Reference 15	FC.15

Table 7-2 Multi-reference Setting

Acceleration/Deceleration Time Selection			
acceleration/ deceleration time terminal 2	Acceleration/deceleration time terminal 1	Acceleration /deceleration time selection	Corresponding parameter
OFF	OFF	Acceleration time1	F0.17、F0.18
OFF	ON	Acceleration time2	F4.03、F4.04
ON	OFF	Acceleration time3	F4.05、F4.06
ON	ON	Acceleration time4	F4.07、F4.08

Acceleration/Deceleration Time Selection

F2.10	X filter time	Range:0.000s~1.000s	Default:0.010s
-------	---------------	---------------------	----------------

It is used to set the software filter time of X terminal status. If X terminals are liable to interference and may cause malfunction, increase the value of this parameter to enhance the anti-interference capability. However, increase of X filter time will reduce the response of X terminals.

F2.11	Terminal command mode	Range:0~3	Default:0
-------	-----------------------	-----------	-----------

0: Two-line mode 1

It is the most commonly used two-line mode, in which the forward/reverse rotation of the motor is decided by X1 and X2.

K1	K2	RUN Command
1	0	Forward RUN
0	1	Reverse RUN
1	1	STOP
0	0	STOP

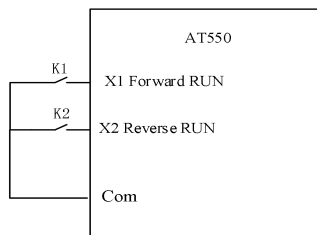

1: Two-line mode 2

In this mode, DI1 is RUN enabled terminal, and DI2 determines the running direction.

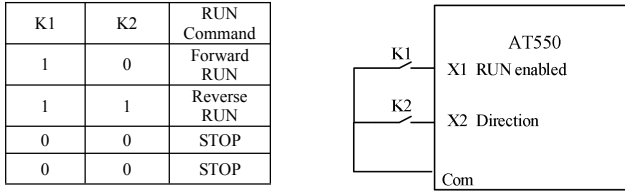

Figure7.4 Setting of two-line mode 2

As shown in the preceding Figure , if K1 is ON, the inverter instructs forward rotation when K2 is OFF, and instructs reverse rotation when K2 is ON. If K1 is OFF, the inverter stops.

2: Three-line mode 1

In this mode, X3 is RUN enabled terminal, and the direction is decided by X1 and X2.

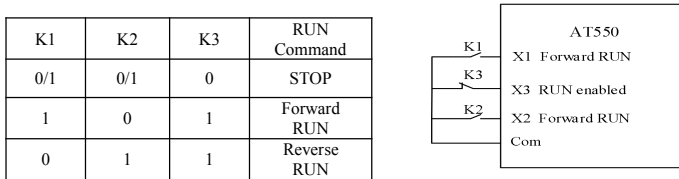

Figure7.5 Setting of three-line mode 1

3: Three-line mode 2

In this mode, X3 is RUN enabled terminal. The RUN command is given by X1 and the direction is decided by X2.

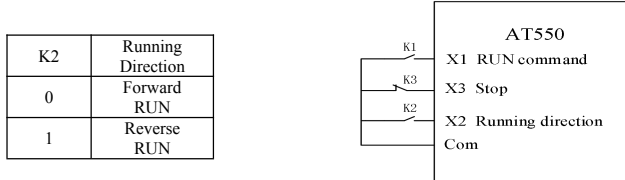

Figure7.6 Setting of three-line mode 2

F2.12	Terminal UP/DOWN rate	Range:0.001~65.353	Default:1.000
-------	-----------------------	--------------------	---------------

It is used to adjust the rate of change of frequency when the frequency is adjusted by means of terminal UP/DOWN.

F2.13	AI1 filter time	Range:0.00s~10.00s	Default:0.10s
F2.14	AI2 filter time	Range:0.00s~10.00s	Default:0.10s
F2.15	AI3 filter time	Range:0.00s~10.00s	Default:0.10s

Definition analog input terminal AI1, AI2 and keyboard potentiometer filter time, the input signal filtering. Long filtering time, the anti-interference ability, but the slow response; filtering the fast response time is short, but weak anti-interference ability.

F2.16	AI curve 1 minimum input	Range:0.00V~F2.18	Default:0.20V
F2.17	Corresponding setting of AI curve 1 minimum input	Range:-100.0%~100.0%	Default:0.0%
F2.18	AI curve 1 maximum input	Range:F2.16~+10.00V	Default:10.00V
F2.19	Corresponding setting of AI curve 1 maximum input	Range:-100.0%~100.0%	Default:100.0%

These parameters are used to define the relationship between the analog input voltage and the corresponding setting. When the analog input voltage exceeds the maximum value (F2.16), the maximum value is used. When the analog input voltage is less than the minimum value (F2.18), the value set in F2.34 (Setting for AI less than minimum input) is used.

Two typical setting examples are shown in the following Figure .

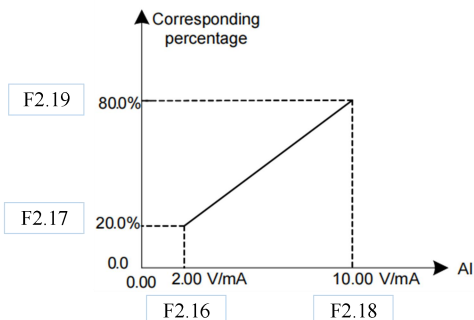
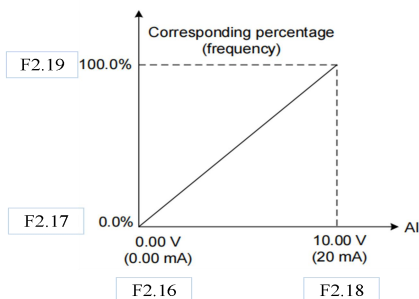

F2.20	AI curve 2 minimum input	Range:0.00V~F2.22	Default:0.20V
F2.21	Corresponding setting of AI curve 2 minimum input	Range:-100.0%~+100.0%	Default:0.0%
F2.22	AI curve 2maximum input	Range:F2.20~+10.00V	Default:10.00V
F2.23	Corresponding setting of AI curve 2maximum input	Range:-100.0%~+100.0%	Default:100.0%
F2.24	AI curve 3 minimum input	Range:0.00V~F2.26	Default:0.20V
F2.25	Corresponding setting of AI curve 3 minimum input	Range:-100.0%~+100.0%	Default:0.0%
F2.26	AI curve 3 maximum input	Range:F2.24~+10.00V	Default:10.00V
F2.27	Corresponding setting of AI curve 3 maximum input	Range:-100.0%~+100.0%	Default:100.0%

Please refer to the AI1 when use AI2 and AI3 curve function.

F2.28	PULSE minimum input	Range:0.00kHz~F2.30	Default:0.00kHz
F2.29	Corresponding setting of PULSE minimum input	Range:-100.0%~100.0%	Default:0.0%
F2.30	PULSE maximum input	Range:F2.28~100.00kHz	Default:50.00kHz
F2.31	Corresponding setting of PULSE maximum input	Range:-100.0%~100.0%	Default:100.0%

This group function code is used to set the relationship between the pulse frequency and the corresponding set X5 between. Pulse frequency inverter can only enter through X5 channel.

F2.32	PULSE filter time	Range:0.00s~10.00s	Default:0.10s
-------	-------------------	--------------------	---------------

PULSE input filtering time is defined on the input signal filtering. Long filtering time the strong anti-interference ability, but the corresponding slowdowns; filtering the fast response time is short, but immunity is weakened.

F2.33	AI curve selection	Range:000~555	Default:321
Hundred's digit(AI3curve selection)		Ten's digit (AI2 curve selection)	Unit's digit (AI1 curve selection)
1:Curve 1:F2.16~F2.19 2:Curve 2:F2.20~F2.23 3:Curve 3:F2.24~F2.27 4:Curve 4:P0.00~P0.07 5:Curve 5:P0.08~P0.15		1:Curve 1:F2.16~F2.19 2:Curve2:F2.20~F2.23 3:Curve3:F2.24~F2.27 4:Curve4:P0.00~P0.07 5:Curve5:P0.08~P0.15	1:Curve 1:F2.16~F2.19 2:Curve2:F2.20~F2.23 3:Curve3:F2.24~F2.27 4:Curve4:P0.00~P0.07 5:Curve5:P0.08~P0.15

The unit's digit, ten's digit and hundred's digit of this parameter are respectively used to select the corresponding curve of AI1, AI2 and AI3. Any of the five curves can be selected for AI1, AI2 and AI3.

F2.34	Setting for AI less than minimum input	Range:000~111	Default:000
-------	--	---------------	-------------

This parameter is used to determine the corresponding setting when the analog input voltage is less than the minimum value. The unit's digit, ten's digit and hundred's digit of this parameter respectively correspond to the setting for AI2, AI2 and AI3.

If the value of a certain digit is 0, when analog input voltage is less than the minimum input, the corresponding setting of the minimum input (F2.17,F2.21,F2.25) is used.

If the value of a certain digit is 1, when analog input voltage is less than the minimum input, the corresponding value of this analog input is 0.0%.

F2.35	X1 switch-on delay	0.0s~3600.0s	0.0s
F2.36	X1 switch-off delay	0.0s~3600.0s	0.0s
F2.37	X2 switch-on delay	0.0s~3600.0s	0.0s
F2.38	X2 switch-off delay	0.0s~3600.0s	0.0s
F2.39	X3 switch-on delay	0.0s~3600.0s	0.0s
F2.40	X3 switch-off delay	0.0s~3600.0s	0.0s

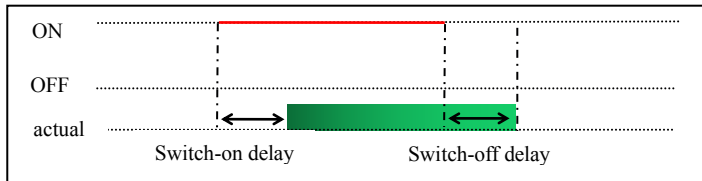

F2.41	X valid mode selection	Range:00000~11111	Default:00000		
Ten thousand's digit		Thousand's digit	Hundred's digit	Ten's digit	Unit's digit
X5		X4	X3	X2	X1

0: High level valid

The X terminal is valid when connected with COM, and invalid when disconnected from COM.

1: Low level valid

The X terminal is invalid when connected with COM, and invalid when disconnected from COM.

### Group F3:Output Terminals

F3.00	Y2/DO terminal output mode	Range:0~1	Default:1
-------	----------------------------	-----------	-----------

Y2 / DO terminal is re-programmable terminals, can be used as high-speed pulse output terminal (DO), can be used as an open-collector digital output terminal (Y2).

0: Pulse output (FMP)

1: Switch signal output (FMR)

DO as a pulse output, the maximum frequency of the output pulse is 100kHz, DO-related functions, see Note F3.06.

F3.01	Y1 function (open collector output terminal)	Range:0~45	Default:1
F3.02	Y2 function (open collector output terminal)	Range:0~45	Default:0
F3.03	R relay output function selection	Range:0~45	Default:2
F3.04	E relay output function selection	Range:0~45	Default:0

## Functions of output terminals:

Value	Function	Description
0	No output	
1	inverter running	When the inverter is running and has output frequency(can be zero), the terminal becomes ON.
2	Fault output (stop)	When the inverter stops due to a fault, the terminal becomes ON.
3	Frequency-level detection FDT1 output	Refer to the descriptions of F4.19,F4.20.
4	Frequency reached	When the output frequency and set frequency error is less than F4.21 (percentage of the maximum frequency with respect to) the set value, the output ON.
5	Zero-speed running (no output at stop)	If the inverter runs with the output frequency of 0, the terminal becomes ON. If the inverter is in the stop state,the terminal becomes OFF.
6	Motor overload pre-warning	The inverter judges whether the motor load exceeds the overload pre-warning threshold before performing the protection action. If the pre-warning threshold is exceeded,the terminal becomes ON. For motor overload parameters,see the descriptions of F9.00~F9.02.
7	inverter overload pre-warning	The terminal becomes ON 10s before the inverter overload protection action is performed.
8	Set count value reached	The terminal becomes ON when the count value reaches the value set in Fb.08
9	Designated count value reached	The terminal becomes ON when the count value reaches the value set in group Fb
10	Length reached	The terminal becomes ON when the detected actual length exceeds the value set in Fb.05
11	PLC cycle complete	When simple PLC completes one cycle, the terminal outputs a pulse signal with width of 250 ms.
12	Accumulative running time reached	If the accumulative running time of the inverter exceeds the time set in F4.17, the terminal becomes ON
13	Frequency limited	If the set frequency exceeds the frequency upper limit or lower limit and the output frequency of the inverter reaches the upper limit or lower limit, the terminal becomes ON.
14	Torque limited	In speed control mode, if the output torque reaches the torque limit, the inverter enters the stall protection state and meanwhile the terminal becomes ON.
15	Ready for RUN	If the inverter main circuit and control circuit become stable, and the inverter detects no fault and is ready for RUN, the terminal becomes ON.
16	A11>A12	When the input of A11 is larger than tA12, the terminal ON.
17	Frequency upper limit reached	If the running frequency reaches the upper limit, the terminal becomes ON.
18	Frequency lower limit reached (no output at stop)	If the running frequency reaches the lower limit, the terminal becomes ON. In the stop state, the terminal becomes OFF.
19	Under voltage state output	If the inverter is in undervoltage state, the terminal becomes ON.
20	Communication setting	Refer to the communication protocol.
23	Zero-speed running 2	If the output frequency of the inverter is 0, the terminal becomes ON. In the state of stop, the signal is still ON.
24	Accumulative power-on time reached	If the inverter accumulative power-on time (F8.13)exceeds the value set in F4.16, the terminal becomes ON.



25	Frequency level detection FDT2 output	Refer to the descriptions of F4.28 and F4.29
26	Frequency 1 reached	Refer to the descriptions of F4.30 and F4.31
27	Frequency 2 reached	Refer to the descriptions of F4.32 and F4.33
28	Current 1 reached	Refer to the descriptions of F4.38 and F4.39
29	Current 2 reached	Refer to the descriptions of F4.40 and F4.41
30	Timing reached	If the timing function (F4.42) is valid, the terminal becomes ON after the current running time of the inverter reaches the set time.
31	A11 input limit exceeded	If A11 input is larger than the value of F4.46 (A11 input voltage upper limit) or lower than the value of F4.45 (A11 input voltage lower limit), the terminal becomes ON.
32	Load becoming 0	If the load becomes 0, the terminal becomes ON.
33	Reverse running	If the inverter is in the reverse running state, the terminal becomes ON.
34	Zero current state	Refer to the descriptions of F4.34 ,F4.35
35	Module temperature reached	If the heatsink temperature of the inverter module (F8.07)reaches the set module temperature threshold (F4.47), the terminal becomes ON
36	Software current limit exceeded	Refer to the descriptions of F4.36,F4.37
37	Frequency lower limit reached	If the running frequency reaches the lower limit, the terminal becomes ON. In the stop state, the signal is still ON
38	Alarm output	If a fault occurs on the inverter and the inverter continues to run, the terminal outputs the alarm signal.
40	Current running time reached	If the current running time of inverter exceeds the value of F4.53, the terminal becomes ON.
41	Analog levels:ADT1	Output OFF when the analog input voltage is higher than F4.57, the output is ON, less than F4.56
42	Analog levels:ADT2	When the analog input voltage is higher than F4.59, output ON, OFF output below the F4.58
44	The X1 state	The X1 current state
45	The X2 state	The X2 current state

Table 7-4 Functions of output terminals

F3.06	DO output function selection	Range:0~16	Default:0
F3.07	AO1 output function selection	Range:0~16	Default:0
F3.08	AO2 output function selection	Range:0~16	Default:1

DO terminal output pulse frequency range of 0.01kHz ~ F3.09 (DO maximum output frequency), F3.09 can be set between 0.01kHz ~ 100.00kHz.

Analog output AO1 and AO2 output range of 0V ~ 10V, or 0mA ~ 20mA.

Value	Function	Range
0	Running frequency	0 to maximum output frequency
1	Set frequency	0 to maximum output frequency
2	Output current	0 to 2 times of rated motor current
3	Output torque	0 to 2 times of rated motor torque
4	Output power	0 to 2 times of rated power
5	Output voltage	0 to 1.2 times of rated inverter voltage
6	Pulse input	0.01kHz~100.00kHz
7	A11	0V~10V
8	A12	0V~10V (0~20mA)
9	A13	0V~10V
10	Length	0 to maximum set length
11	Count value	0 to maximum count value
12	Communication setting	0.0%~100.0%
13	Motor rotational speed	0 to rotational speed corresponding to output max.freq
14	Output current	0.0A~1000.0A
15	Output voltage	0.0V~1000.0V

F3.09	Output max.Freq of DO	Range:0.01kHz~100.00kHz	Default:50.00Hz
F3.10	AO1 offset coefficient	Range:-100.0~+100.0	Default:0.0
F3.11	AO1 gain	Range:-10.00~+10.00	Default:1.00
F3.12	AO2 offset coefficient	Range:-100.0~+100.0	Default:0.0
F3.13	AO2 gain	Range:-10.00~+10.00	Default:1.00

These four function parameters generally correct zero offset of analog output and output amplitude error. They can also define required AO curve.

Zero offset coefficient 100% of AO1 and AO2 corresponds to 10 V or 20 mA. You can calculate the gain and the zero offset coefficient from the following formulas:

$$K = \frac{(Y1 - Y2) * X \text{ max}}{(X1 - X2) * Y \text{ max}} \quad b = \frac{(X1 * Y2 - X2 * Y1)}{(X1 - X2) * Y \text{ max}} * 100\%$$

For example, AO1 is used for output of frequency reference. To implement output of 2 V (Y1) at 0 Hz (x1) and output of 10 V (Y2) at 50 Hz (X2) according to the formulas, you can obtain gain and zero offset coefficient as follows:

$$K = \frac{(2 - 10) * 50}{(0 - 50) * 10} = 0.8 \quad b = \frac{(0 * 10 - 50 * 2)}{(0 - 50) * 10} * 100\% = 20\%$$

Then you can set F3.10 to 20 and set F3.11 to 0.8

In the formulas:

- "b" represents zero offset.
- "k" represents gain.
- "X" represents output frequency.
- "Y" represents actual output of the AO.
- "Xmax " represents max. output frequency (determined by F0-10).
- "Ymax" represents max. output 10 V or 20 mA.

AO output signal type and corresponding max. value are as follows:

AO output signal	Corresponding Max. Output (Ymax)
Voltage	10 V
Current	20 mA

F3.14	Y1 switch-on delay	0.0s~3600.0s	0.0s
F3.15	Y1 switch-off delay	0.0s~3600.0s	0.0s
F3.16	Y2 switch-on delay	0.0s~3600.0s	0.0s
F3.17	Y2 switch-off delay	0.0s~3600.0s	0.0s
F3.18	R-relay switch-on delay	0.0s~3600.0s	0.0s
F3.19	R-relay switch-off delay	0.0s~3600.0s	0.0s
F3.20	E-relay switch-on delay	0.0s~3600.0s	0.0s
F3.21	E-relay switch-off delay	0.0s~3600.0s	0.0s
F3.22	Monopulse Output Time Y1	0.0s~30.0s	0.0s
F3.23	Monopulse Output Time Y2	0.0s~30.0s	0.0s
F3.24	Monopulse Output Time Relay R	0.0s~30.0s	0.0s
F3.25	Monopulse Output Time Relay E	0.0s~30.0s	0.0s

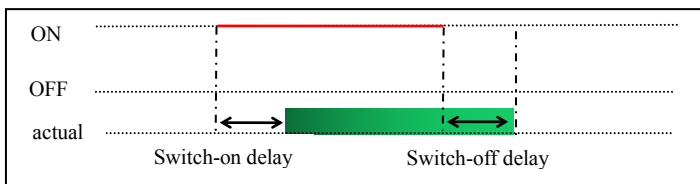

F3.27	Output terminals valid mode selection	Range:0000~1111	Default:0000
It is used to set the logic of output terminals Y1, Y2, relay R, relay R			
0: Positive logic			
1: Positive logic			

### Group F4: Auxiliary Functions

F4.00	JOG running frequency	Range:0.00Hz~the max.freq	Default:2.00Hz
F4.01	JOG acceleration time	Range:0.0s~6500.0s	Default:20.0s
F4.02	JOG deceleration time	Range:0.0s~6500.0s	Default:20.0s

These parameters are used to define the set frequency and acceleration/deceleration time of the inverter when jogging. The startup mode is "Direct start" (F7.00 = 0) and the stop mode is "Decelerate to stop" (F7.10 = 0) during jogging.

F4.03	Acceleration time 2	Range:0.0s~6500.0s	Default:Model dependent
F4.04	Deceleration time 2	Range:0.0s~6500.0s	Default:Model dependent
F4.05	Acceleration time 3	Range:0.0s~6500.0s	Default:Model dependent
F4.06	Deceleration time 3	Range:0.0s~6500.0s	Default:Model dependent
F4.07	Acceleration time 4	Range:0.0s~6500.0s	Default:Model dependent
F4.08	Deceleration time 4	Range:0.0s~6500.0s	Default:Model dependent

The AT550 provides a total of four groups of acceleration/deceleration time, that is, the preceding three groups and the group defined by F0.17 and F0.18. Definitions of four groups are completely the same. You can switch over between the four groups of acceleration/deceleration time through different state combinations of X terminals. For more details, see the descriptions of F2.00 to F2.04

F4.09	Jump frequency 1	Range:0.00Hz~the max.freq	Default:0.00Hz
F4.10	Jump frequency 2	Range:0.00Hz~the max.freq	Default:0.00Hz
F4.11	Frequency jump amplitude	Range:0.00Hz~the max.freq	Default:0.01Hz

If the set frequency is within the frequency jump range, the actual running frequency is the jump frequency close to the set frequency. Setting the jump frequency helps to avoid the mechanical resonance point of the load.

The AT550 supports two jump frequencies. If both are set to 0, the frequency jump function is disabled. The principle of the jump frequencies and jump amplitude is shown in the following Figure .

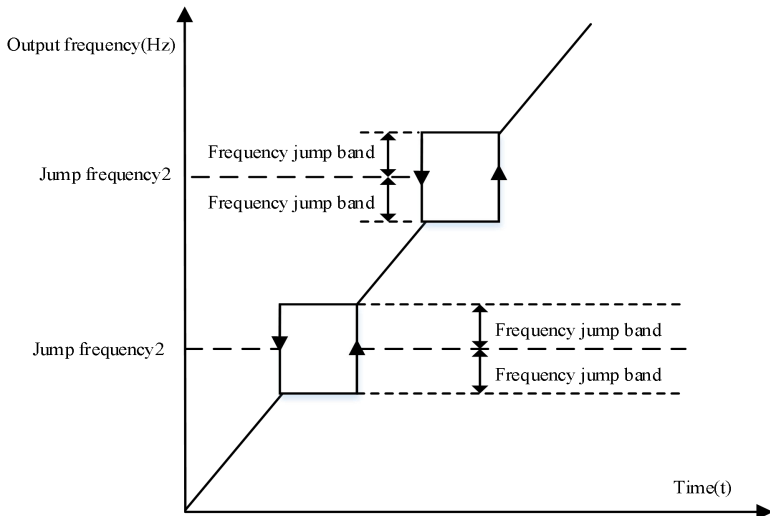

F4.12	Forward/Reverse rotation dead-zone time	Range:0.0s~3000.0s	Default:0.0s
-------	---	--------------------	--------------

It is used to set the time when the output is 0 Hz at transition of the inverter forward rotation and reverse rotation, as shown in the following Figure .

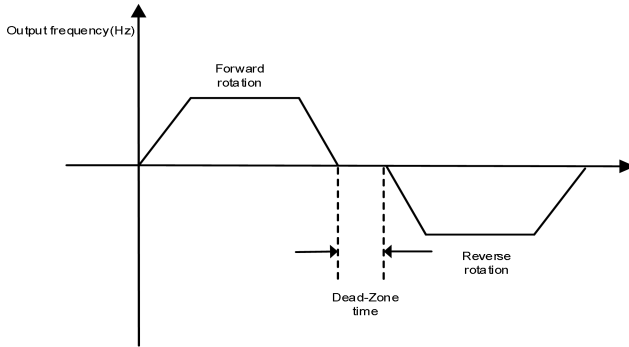

F4.13	Reverse control	Range:0~1	Default:0
-------	-----------------	-----------	-----------

0: Enabled

1: Disabled

It is used to set whether the inverter allows reverse rotation. In the applications where reverse rotation is prohibited, set this parameter to 1.

F4.14	Running mode when set frequency lower than frequency lower limit	Range:0~2	Default:0
-------	--	-----------	-----------

It is used to set the inverter running mode when the set frequency is lower than the frequency lower limit. The AT550 provides three running modes to satisfy requirements of various applications

0: Run at frequency lower limit

1: Stop

2: Run at zero speed

F4.15	Droop control	Range:0.00Hz~10.00Hz	Default:0.00Hz
-------	---------------	----------------------	----------------

The function is typically used for load sharing with multiple motors drag a load. Droop control refers to as the load increases, the inverter output frequency decreases, so more than one motor drive the same load, the load of the motor output frequency drops more, which can reduce the load on the motor to achieve multiple motors load evenly. This parameter refers to the inverter rated output load, the output frequency decreases value.

F4.16	Accumulative power-on time threshold	Range:0s~65000h	Default:0h
-------	--------------------------------------	-----------------	------------

If the accumulative power-on time (F8.13) reaches the value set in this parameter, the corresponding DO terminal becomes ON.

F4.17	Accumulative running time threshold	Range:0s~65000h	Default:0h
-------	-------------------------------------	-----------------	------------

It is used to set the accumulative running time threshold of the inverter. If the accumulative running time (F8.13) reaches the value set in this parameter, the corresponding digital output terminal becomes ON.

F4.18	Startup protection	Range:0~1	Default:0
-------	--------------------	-----------	-----------

This parameter is used to set whether to enable the safety protection. If it is set to 1, the inverter does not respond to the run command valid upon inverter power-on (for example, an input terminal is ON before power-on). The inverter responds only after the run command is canceled and becomes valid again. In addition, the inverter does not respond to the run command valid upon fault reset of the inverter. The run protection can be disabled only after the run command is canceled.

In this way, the motor can be protected from responding to run commands upon power-on or fault reset in unexpected conditions.

F4.19	Frequency detection value (FDT1)	Range:0.00Hz~max.freq	Default:50.00Hz
F4.20	Frequency detection hysteresis (FDT hysteresis 1)	Range:0.0%~100.0%	Default:5.0%

If the running frequency is higher than the value of F4.19, the corresponding Y terminal becomes ON. If the running frequency is lower than value of F4.19, the DO terminal goes OFF.

These two parameters are respectively used to set the detection value of output frequency and hysteresis value upon cancellation of the output. The value of F4.20 is a percentage of the hysteresis frequency to the frequency detection value (F4.19).The FDT function is shown in the following Figure .

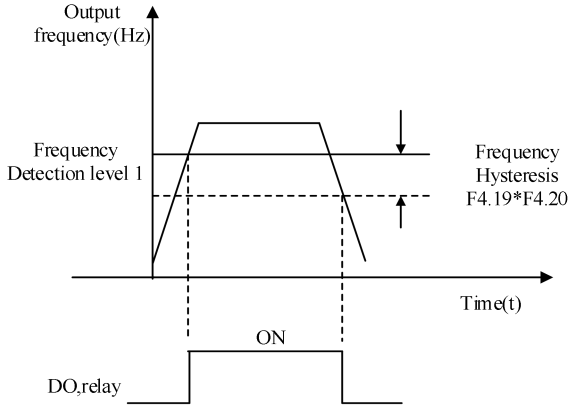

F4.21	Detection range of frequency reached	Range:0.0%~100.0%	Default:0.0%
-------	--------------------------------------	-------------------	--------------

If the inverter running frequency is within the certain range of the set frequency, the corresponding DO terminal becomes ON.

This parameter is used to set the range within which the output frequency is detected to reach the set frequency. The value of this parameter is a percentage relative to the maximum frequency. The detection range of frequency reached is shown in the following figure .

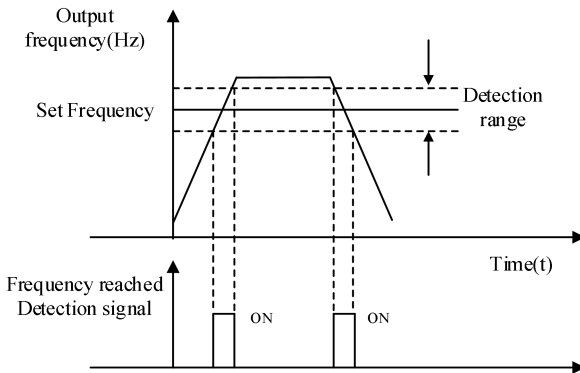

F4.22	Jump frequency during acceleration/deceleration	Range:0~1	Default:0
-------	---	-----------	-----------

- 0: Disabled
- 1: Enabled

It is used to set whether the jump frequencies are valid during acceleration/deceleration. When the jump frequencies are valid during acceleration/deceleration, and the running frequency is within the frequency jump range, the actual running frequency will jump over the set frequency jump amplitude.

F4.25	Frequency switchover of acceleration time 1 and acceleration time 2	Range:0.00Hz~max.freq	Default:0.00Hz
F4.26	Frequency switchover of deceleration time 1 and deceleration time 2	Range:0.00Hz~max.freq	Default:0.00Hz

This function is valid when acceleration/deceleration time switchover is not performed by means of X terminal. It is used to select different groups of acceleration/deceleration time based on the running frequency range rather than X terminal during the running process of the inverter.

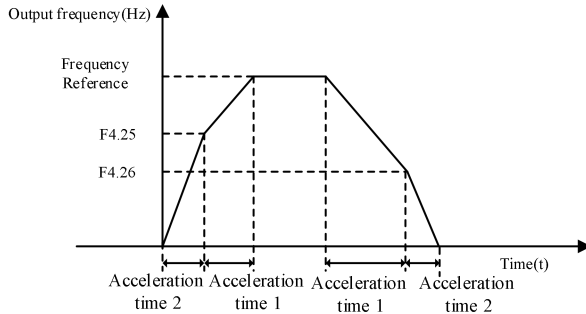

F4.27	Terminal JOG preferred	Range:0~1	Default:0
-------	------------------------	-----------	-----------

- 0: Disabled
- 1: Enabled

It is used to set whether terminal JOG is preferred.

If terminal JOG is preferred, the inverter switches to terminal JOG running state when there is a terminal JOG command during the running process of the inverter.

F4.28	Frequency detection value (FDT2)	Range:0.00Hz~max.freq	Default:50.00Hz
F4.29	Frequency detection hysteresis (FDT hysteresis 2)	Range:0.0%~100.0%	Default:5.0%

Refer to description of F4.19, F4.20

F4.30	Any frequency reaching detection value 1	Range:0.00Hz~max.freq	Default:50.00Hz
F4.31	Any frequency reaching detection amplitude 1	Range:0.0%~100.0%	Default:0.0%
F4.32	Any frequency reaching detection value 2	Range:0.00Hz~max.freq	Default:50.00Hz
F4.33	Any frequency reaching detection amplitude 2	Range:0.0%~100.0%	Default:0.0%

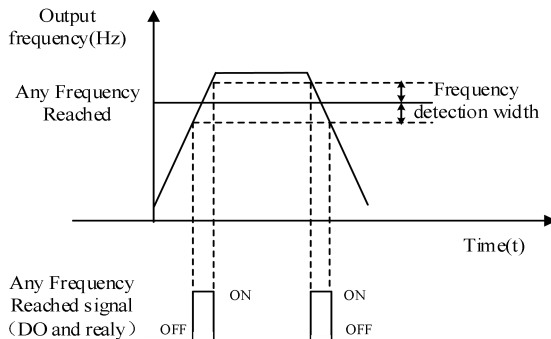

If the output frequency of the inverter is within the positive and negative amplitudes of the any frequency reaching detection value, the corresponding digital output becomes ON.

F4.34	Zero current detection level	Range:0.0%~300.0%	Default:5.0%
F4.35	Zero current detection delay time	Range:0.01s~600.00s	Default:0.10s

If the output current of the inverter is equal to or less than the zero current detection level and the duration exceeds the zero current detection delay time, the corresponding output terminal becomes ON. The zero current detection is shown in the following figure .

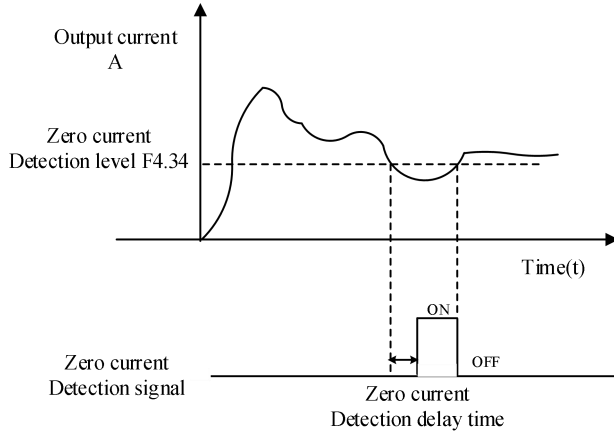

F4.36	Output overcurrent threshold	Range: 0.0%~300.0%	Default:200.0%
F4.37	Output overcurrent detection delay time	Range:0.00s~600.00s	Default:0.00s

If the output current of the inverter is equal to or higher than the overcurrent threshold and the duration exceeds the detection delay time, the corresponding output terminal becomes ON. The output overcurrent detection function is shown in the following Figure .

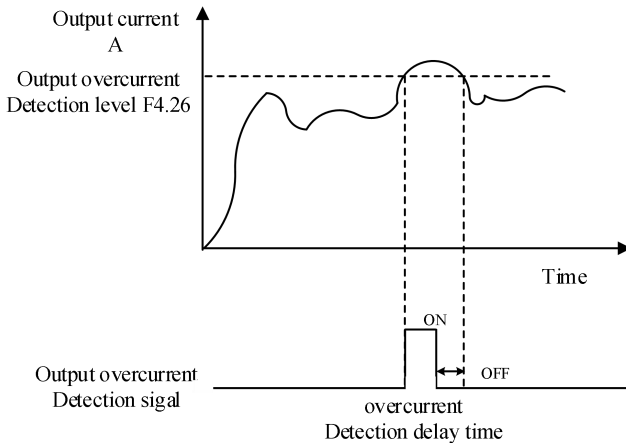

F4.38	Any current reaching 1	Range:0.0%~300.0%	Default:100.0%
F4.39	Any current reaching 1 amplitude	Range:0.0%~300.0%	Default:0.0%
F4.40	Any current reaching 2	Range:0.0%~300.0%	Default:100.0%
F4.41	Any current reaching 2 amplitude	Range:0.0%~300.0%	Default:0.0%

If the output current of the inverter is within the positive and negative amplitudes of any current reaching detection value, the corresponding output terminal becomes ON.

The AT550 provides two groups of any current reaching detection parameters, including current detection value and detection amplitudes, as shown in the following Figure .

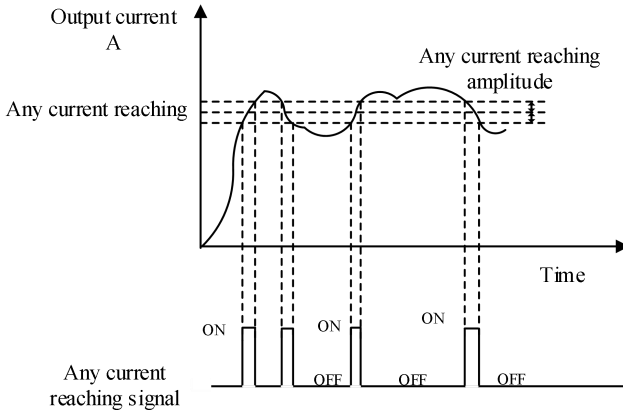

F4.42	Timing function	Range:0~1	Default:0
-------	-----------------	-----------	-----------

0: Disabled  
1: Enabled

F4.43	Timing duration source	Range:0~3	Default:0
-------	------------------------	-----------	-----------

0:F4.44  
1:A11  
2:A12  
3:A13(100% of analog input corresponds to the value of F4.44)

F4.44	Timing duration	Range:0.0Min~6500.0Min	Default:0.0Min
-------	-----------------	------------------------	----------------

These parameters are used to implement the inverter timing function.

If F4.42 is set to 1, the inverter starts to time at startup. When the set timing duration is reached, the inverter stops automatically and meanwhile the corresponding DO becomes ON.

The inverter starts timing from 0 each time it starts up and the remaining timing duration can be queried by H0.28.

The timing duration is set in F4.43 and F4.44, in unit of minute.

F4.45	All input voltage lower limit	Range:0.00V~F4.46	Default:3.10V
-------	-------------------------------	-------------------	---------------

F4.46	All input voltage upper limit	Range:F4.45~10.00V	Default:6.80V
-------	-------------------------------	--------------------	---------------

These two parameters are used to set the limits of the input voltage to provide protection on the inverter. When the A11 input is larger than the value of F4.46 or smaller than the value of F4.45, the corresponding output terminal becomes ON, indicating that A11 input exceeds the limit.

F4.47	Module temperature threshold	Range:0~100	Default:75°C
-------	------------------------------	-------------	--------------

When the heatsink temperature of the inverter reaches the value of this parameter, the corresponding output terminal becomes ON, indicating that the module temperature reaches the threshold.

F4.48	Cooling fan control	Range:0~1	Default:0
-------	---------------------	-----------	-----------

It is used to set the working mode of the cooling fan. If this parameter is set to 0, the fan works when the inverter is in running state. When the inverter stops, the cooling fan works if the heatsink temperature is higher than 40° C, and stops working if the heatsink temperature is lower than 40° C.

If this parameter is set to 1, the cooling fan keeps working after power on.



F4.49	Wakeup frequency	Range:F4.51~F0.10	Default:0.00Hz
F4.50	Wakeup delay time	Range:0.0s~6500.0s	Default:0.0s
F4.51	Dormant frequency	Range:0.00Hz~F4.49	Default:0.00Hz
F4.52	Dormant delay time	Range:0.0~6500.0s	Default:0.0s

These parameters are used to implement the dormant and wakeup functions in the water supply application.

When the inverter is in running state, the inverter enters the dormant state and stops automatically after the dormant delay time (F4.52) if the set frequency is lower than or equal to the dormant frequency (F4.51).

When the inverter is in dormant state and the current running command is effective, the inverter starts up after the wakeup delay time (F4.50) if the set frequency is higher than or equal to the wakeup frequency (F4.49).

Generally, set the wakeup frequency equal to or higher than the dormant frequency. If the wakeup frequency and dormant frequency are set to 0, the dormant and wakeup functions are disabled.

When the dormant function is enabled, if the frequency source is PID, whether PID operation is performed in the dormant state is determined by FA.28. In this case, select PID operation enabled in the stop state (FA.28 = 1).

F4.53	Current running time reached	Range:0.0Min~6500.0Min	Default:0.0Min
-------	------------------------------	------------------------	----------------

If the current running time reaches the value set in this parameter, the corresponding output terminal becomes ON, indicating that the current running time is reached.

F4.54	ADT1 channel selection	Unit's digit: 0:A11 1:A12 Ten's digit: 0:No output when stop 1:Output when stop	Default:00
F4.55	ADT2 channel selection	Unit's digit: 0:A11 1:A12 Ten's digit: 0:No output when stop 1:Output when stop	Default:01
F4.56	ADT1 output upper limit	F4.57~10.00	Default:10.00V
F4.57	ADT1 output lower limit	0.00~F4.56	Default:0.00V
F4.58	ADT2 output upper limit	F4.59~10.00	Default:10.00V
F4.59	ADT2 output lower limit	0.00~F4.58	Default:0.00V

When the AI voltage is higher than the ADT upper limit value, the inverter function output terminal (41/42: Frequency detection ADT1 / ADT2 output) will be ON, and the frequency is below the lower limit value of ADT, the ON signal is canceled.

## Group F5: Vector Control Parameters

F5.00	Speed loop proportional gain 1	1~100	Default:30
F5.01	Speed loop integral time 1	0.01s~10.00s	Default:0.50s
F5.02	Switchover frequency 1	0.00~F5.05	Default:5.00Hz
F5.03	Speed loop proportional gain 2	1~100	Default:20
F5.04	Speed loop integral time 2	0.01s~10.00s	Default:1.00s
F5.05	Switchover frequency 2	F5.02~max.freq	Default:10.00Hz

F5-00 to F5-05 are speed loop PI parameters.

- If running frequency  $\leq$  F5-02 (Switchover frequency 1), PI parameters are F5-00 and F5-01.
- If running frequency  $\geq$  F5-05 (Switchover frequency 2), PI parameters are F5-03 and F5-04.
- If running frequency is between F5-02 and F5-05, PI parameters are obtained from linear switchover between two groups of PI parameters, as shown in Figure.

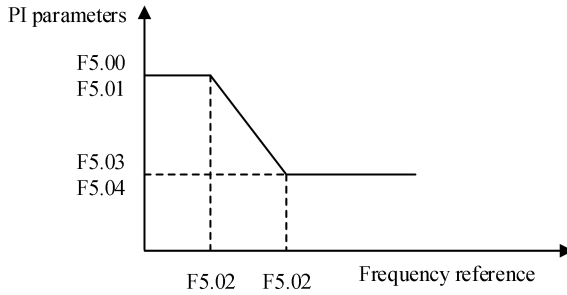

To improve the system response, increase the proportional gain or reduce the integral time. Remember to increase proportional gain first to ensure that the system does not oscillate, and then reduce integral time to ensure that the system has quick response and small overshoot.

Note: Incorrect PI setting may cause large speed overshoots and a fast falling speed drop may cause an over voltage on the DC bus.

F5.06	Vector control slip gain	Range:50%~200%	Default:100%
-------	--------------------------	----------------	--------------

This function improves control performance in SVC/FVC (F0-01 = 0/1).

For FVC (F0-01 = 1), it can adjust output current of the AC drive. Decrease this parameter gradually when a large rating AC drive is controlling a lightly loaded motor. Adjustment of this parameter is not required normally.

F5.07	Time constant of speed loop filter	Range:0.000s~0.100s	Default:0.000s
-------	------------------------------------	---------------------	----------------

This parameter takes effect only when F0-01 = 0. You can improve motor stability by increasing F5.07. Be aware that this may slow dynamic response. Decreasing it will obtain quick system response but may lead to motor oscillation. Adjustment of this parameter is not required normally.

F5.08	Vector control over excitation gain	Range:0~200	Default:64
-------	-------------------------------------	-------------	------------

During deceleration, over-excitation control can restrain rise of the bus voltage to avoid the over-voltage fault. The larger the over-excitation gain is, the better the restraining effect is.

Increase the over-excitation gain if the inverter is liable to over-voltage error during deceleration. Too large over-excitation gain, however, may lead to an increase in output current. Therefore, set this parameter to a proper value in actual applications.

Set the over-excitation gain to 0 in applications of small inertia (the bus voltage will not rise during deceleration) or where there is a braking resistor.

F5.09	Torque upper limit source in speed control mode	Range:0~7	Default:0
F5.10	Digital setting of torque upper limit in speed control mode	Range:0.0%~200.0%	Default:150.0%

- 0: Set by F5.10
- 1: AI1
- 2: AI2
- 3: AI3
- 4: Pulse setting (X5)
- 5: Via communication
- 6: MIN(AI1,AI2)
- 7: MAX(AI1,AI2)

When the inverter is in communication with the master, if F5.09 is set to 5 “communication setting”, F5.10 “Digital setting of torque upper limit in speed control mode” can be set via communication from the master.

In other conditions, the host computer writes data -100.00% to 100.00% by the communication address 0x1000, where 100.0% corresponds to the value of F5.10.

F5.13	Excitation adjustment proportional gain	Range:0~60000	Default:2000
F5.14	Excitation adjustment integral gain	Range:0~60000	Default:1300
F5.15	Torque adjustment proportional gain	Range:0~60000	Default:2000
F5.16	Torque adjustment integral gain	Range:0~60000	Default:1300

These function parameters are vector control current loop PI parameters. They are obtained from motor auto-tuning. Adjustment of these parameter is not required normally.

The dimension of current loop integral regulator is integral gain rather than integral time. Very large current loop PI gain may lead to control loop oscillation. When current oscillation or torque fluctuation is great, decrease the proportional gain or integral gain.

## Group F6: V/F Control Parameters

F6.00	V/F curve setting	Range:0~8	Default:0
-------	-------------------	-----------	-----------

0: Linear V/F

It is applicable to common constant torque load.

1: Multi-point V/F

It is applicable to special load such as dehydrator and centrifuge. Any such V/F curve can be obtained by setting parameters of F6.03 to F6.08.

2: Square V/F

3: 1.2-power V/F

4: 1.4-power V/F

6: 1.6-power V/F

8: 1.8-power V/F

2 to 8 is suitable for fans, pumps, centrifugal loads

F6.01	Torque boost	Range:0.0~30.0	Default:Model dependent
F6.02	Cut-off frequency of torque boost	Range:0.00Hz~max.freq	Default:50.00Hz

The torque compensation function compensates for insufficient torque production at low frequency.

F6-01 compensates for insufficient torque production by boosting output voltage of the AC drive. But very large setting will result in motor overheat and AC drive over-current.

- On starting a heavy load and insufficient torque is experienced, increase the torque boost in F6-01.

- Decrease this parameter on light loads to avoid overheating the motor. F6-02 sets the cutoff frequency.

The torque boost function is disengaged when the output frequency exceeds the cutoff point.

F6.03	Multi-point V/F frequency 1	Range:0.00Hz~F6.05	Default:0.00Hz
F6.04	Multi-point V/F voltage 1	Range:0.0%~100.0%	Default:0.0%
F6.05	Multi-point V/F frequency 2	Range:F6.03~F6.07	Default:0.00Hz
F6.06	Multi-point V/F voltage 2	Range:0.0%~100.0%	Default:0.0%
F6.07	Multi-point V/F frequency 3	Range:F6.05~rated motor frequency (F1.04)	Default:0.00Hz
F6.08	Multi-point V/F voltage 3	Range:0.0%~100.0%	Default:0.0%

These six parameters are used to define the multi-point V/F curve.

The multi-point V/F curve is set based on the motor's load characteristic. The relationship between voltages and frequencies is:  $V1 < V2 < V3$ ,  $F1 < F2 < F3$

At low frequency, higher voltage may cause overheat or even burnt out of the motor and overcurrent stall or overcurrent protection of the inverter.

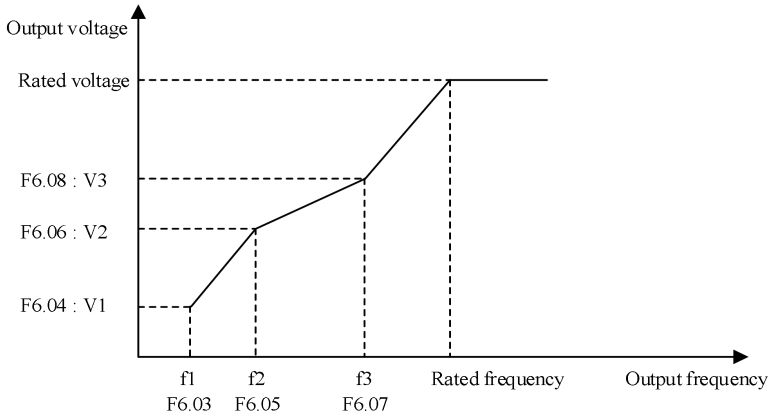

F6.09	V/F slip compensation gain	Range:0.0%~200.0%	Default:0.0%
-------	----------------------------	-------------------	--------------

It can compensate the rotational speed slip of the asynchronous motor when the load of the motor increases, stabilizing the motor speed in case of load change. If this parameter is set to 100%, it indicates that the compensation when the motor bears rated load is the rated motor slip. The rated motor slip is automatically obtained by the inverter through calculation based on the rated motor frequency and rated motor rotational speed in group F1.

Generally, if the motor rotational speed is different from the target speed, slightly adjust this parameter.

F6.10	V/F over-excitation gain	Range:0~200	Default:64
-------	--------------------------	-------------	------------

If actual deceleration time cannot satisfy the requirement, increase the value of F3-10 (V/F over excitation gain) adequately.

When using braking resistor, braking unit or energy feedback unit, set F6.10 (V/F over-excitation gain) to 0. Otherwise, too large current may occur during drive running.

F6.11	V/F oscillation suppression gain	Range:0~100	Default:Mode dependent
-------	----------------------------------	-------------	------------------------

Set this parameter to a value as small as possible in the prerequisite of efficient oscillation suppression to avoid influence on V/F control.

Set this parameter to 0 if the motor has no oscillation. Increase the value properly only when the motor has obvious oscillation. The larger the value is, the better the oscillation suppression result will be.

When the oscillation suppression function is enabled, the rated motor current and no-load current must be correct. Otherwise, the V/F oscillation suppression effect will not be Satisfactory.

F6.13	Limited flow protection function selection	Range: 0~1	Default: 0
F6.14	Current limiting protection value	Range: 0~600 (A)	Default: 70
F6.15	Limited current protection action time	Range: 0.0~60.0(s)	Default: 02.0

When F6.13=1 and output current exceeds the value set in F6.14, the duration greater than f6.15, the inverter will show Error 28 and stop.

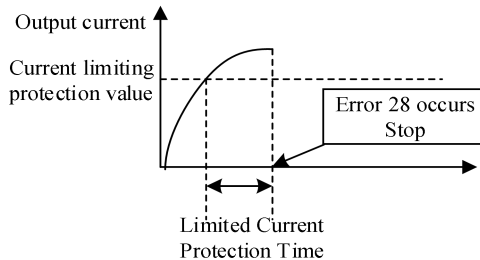

F6.16	Current limit selection	Range: 0: Disabled 1: Enabled	Default: 1
F6.17	Current limit level	Range: 50% to 200%	Default: 150%
F6.18	Current limit gain	Range: 0 to 100	Default: 20

When output current exceeds the value set in F6.17 during acceleration, constant running or deceleration, current limit is enabled and output frequency starts to drop. Until output current recovers below the current limit level, output frequency starts to rise to target frequency again.

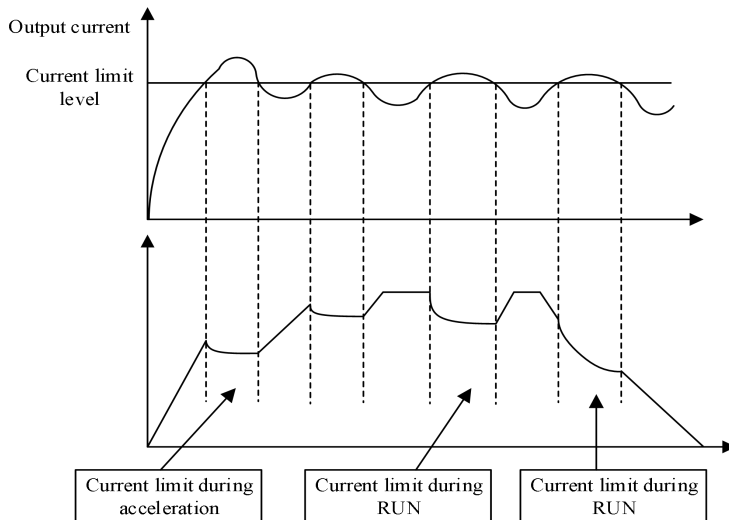

F6.19	Compensation factor of speed multiplying current limit	Range: 50% to 200%	Default: 50%
-------	--	--------------------	--------------

In high frequency area, motor drive current is small. Bigger motor speed dip is caused by current limit level compared with below rated frequency. To improve motor running characteristic, you can lower current limit level above rated frequency.

The current limit function above rated frequency helps to improve acceleration performance in the applications, such as centrifuge, where high running frequency and several times of field weakening are required, and load inertia is large.

F6.20	Voltage limit selection	Range: 0: Disabled 1: Enabled	Default: 1
F6.21	Voltage limit	Range: 120% to 150%	Default: 130%
F6.22	Frequency gain for voltage limit	Range: 0 to 100	Default: 30
F6.23	Voltage gain for voltage limit	Range: 0 to 100	Default: 30
F6.24	Frequency rise threshold during voltage limit	Range: 0 to 50 Hz	Default: 5

When bus voltage rises above the value set in F6.21, the motor becomes regenerative. This function prevents over-voltage trips by adjusting the output frequency to extend deceleration time in this case.

If actual deceleration time cannot satisfy the requirement, increase the value of F6.10 (V/F over excitation gain) adequately.

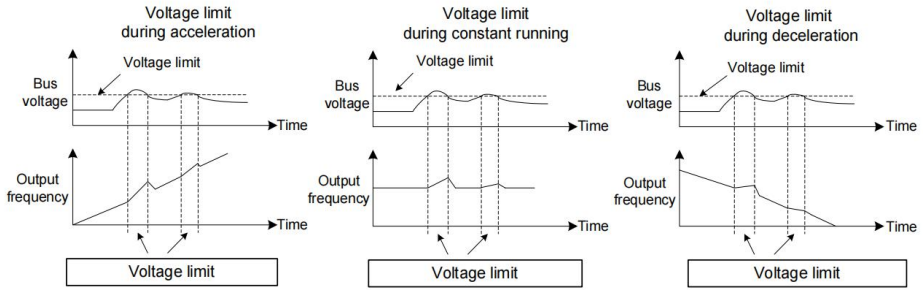

F6.25	Filter Time of V/f Slip Compensation	0~10.0	4.0
-------	--------------------------------------	--------	-----

Used to set the filtering time of V / F slip compensation.

F6.26	Auto-Torque Boost Coefficient	0~200	100
-------	-------------------------------	-------	-----

Adjust the value of automatic torque lifting.

### Group F7: Start/Stop Control

F7.00	Start mode	Range:0~2	Default:0
-------	------------	-----------	-----------

◆ F7.00=0: Direct start

It is applicable to most small-inertia loads, Start frequency is applicable to drive equipment which requires startup torque, such as cement mixer

◆ 1: Rotational speed tracking restart

To catch a spinning motor, the inverter detects speed and direction of spinning motor, and then starts to run from the spinning motor frequency.

In this start mode, ensure that motor parameters in group F1 are set correctly

◆ 2: DC braking restart

The DC injection braking function is applicable to drive load such as elevator and crane

F7.01	Rotational speed tracking mode	Range:0~2	Default:0
-------	--------------------------------	-----------	-----------

To complete the rotational speed tracking process within the shortest time, select the proper mode in which the inverter tracks the motor rotational speed.

● 0: From frequency at stop

It is the commonly selected mode.

● 1: From zero frequency

It is applicable to restart after a long time of stop.

● 2: From the maximum frequency

It is applicable to the larger mechanical inertia.

F7.02	Rotational speed tracking speed	Range:1~100	Default:20
-------	---------------------------------	-------------	------------

In the rotational speed tracking restart mode, select the rotational speed tracking speed. The larger the value is, the faster the tracking is. However, too large value may cause unreliable tracking.

F7.03	Startup frequency	Range:0.00Hz~10.00Hz	Default:0.00Hz
F7.04	Startup frequency holding time	Range:0.0s~100.0s	Default:0.0s

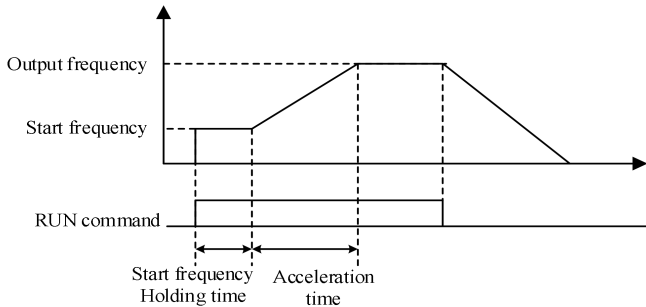

F7.05	Startup DC braking current	0%~100%	0%
F7.06	Startup DC braking time	0.0s~100.0s	0.0s

Startup DC braking is generally used during restart of the inverter after the rotating motor stops. Startup DC braking is valid only for direct start (F7.00 = 0). In this case, the inverter performs DC braking at the set startup DC braking current. After the startup DC braking time, the inverter starts to run. If the startup DC braking time is 0, the inverter starts directly without DC braking.

F7.07	Acceleration/Deceleration mode	Range:0~2	Default:0
-------	--------------------------------	-----------	-----------

It is used to set the frequency change mode during the inverter start and stop process.

- 0: Linear acceleration/deceleration
- 1: S-curve acceleration/deceleration A
- 2: S-curve acceleration/deceleration B

F7.08	Time proportion of S-curve start segment	Range:0.0%~(100.0%-F7.09)	Default:30.0%
F7.09	Time proportion of S-curve end segment	Range:0.0%~(100.0%-F7.08)	Default:30.0%

These two parameters respectively define the time proportions of the start segment and the end segment of S-curve acceleration/deceleration. They must satisfy the requirement:  $F7.08 + F7.09 \leq 100.0\%$ .

F7.10	Stop mode	Range:0~1	Default:0
-------	-----------	-----------	-----------

- 0: Decelerate to stop

After the stop command is enabled, the inverter decreases the output frequency according to the deceleration time and stops when the frequency decreases to zero.

- 1: Coast to stop

After the stop command is enabled, the inverter immediately stops the output. The motor will coast to stop based on the mechanical inertia.

F7.11	Initial frequency of stop DC braking	Range:0.00Hz~max. freq	Default:0.00Hz
F7.12	Waiting time of stop DC braking	Range:0.0s~100.0s	Default:0.0s
F7.13	Stop DC braking current	Range:0%~100%	Default:0%
F7.14	Stop DC braking time	Range:0.0%~100.0%	Default:0.0s

The inverter starts DC injection braking when the running frequency decreases to the value set in this parameter in the process of deceleration to stop.

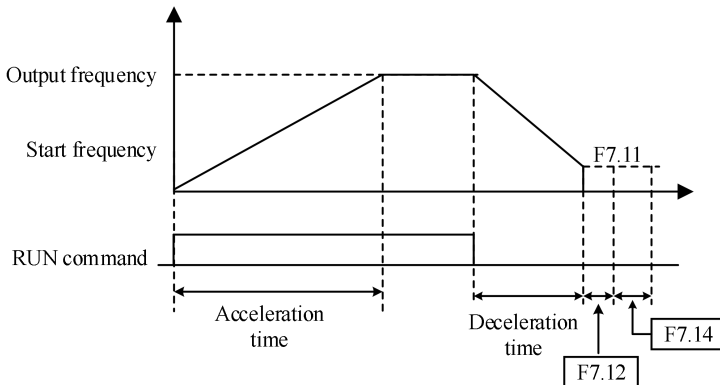

F7.15	Brake use ratio	Range:0%~100%	Default:100%
-------	-----------------	---------------	--------------

It is valid only for the inverter with internal braking unit and used to adjust the duty ratio of the braking unit. The larger the value of this parameter is, the better the braking result will be. However, too larger value causes great fluctuation of the inverter bus voltage during the braking process.

## Group F8: Operation Panel and Display

F8.01	MK Key function selection	Range:0~4	Default:0
-------	---------------------------	-----------	-----------

MK key refers to multifunctional key. You can set the function of the MK key by using this parameter. You can perform switchover by using this key both in stop or running state.

0: MK key disabled

This key is disabled.

1: Switchover between operation panel control and remote command control

You can perform switchover from the current command source to the operation panel control (local operation). If the current command source is operation panel control, this key is invalid.

2: Switchover between forward rotation and reverse rotation

You can change the direction of the frequency reference by using the MK key. It is valid only when the current command source is operation panel control.

3: Forward JOG

You can perform forward JOG (FJOG) by using the MK key.

4: Reverse JOG

You can perform reverse JOG (FJOG) by using the MK key.

F8.02	STOP/RESET key function	Range:0~1	Default:1
-------	-------------------------	-----------	-----------

0: STOP/RESET key enabled only in operation panel control

1: STOP/RESET key enabled in any operation mode

F8.03	LED display running parameters 1	Range:0x0000~0xFFFF	Default:0x001F
-------	----------------------------------	---------------------	----------------

A maximum of 32 parameters in the running status can be viewed in F8.03 and F8.04. The display starts from the lowest bit of F8.03. A total of 13 parameters in the stop can be viewed in F8.05.

Bit07	Bit06	Bit05	Bit04	Bit03	Bit02	Bit01	Bit00
X input status	Bus voltage	Output torque	Output power	Output voltage	Output current	Set frequency	Running frequency
Bit15	Bit14	Bit13	Bit12	Bit11	Bit10	Bit09	Bit08
PID feedback	PID setting	Pulse setting frequency	AI3 voltage	AI2 voltage	AI1 voltage	DO output status	Reserved

F8.04	LED display running parameters 2			Range:0x0000~0xFFFF			Default:0x0000	
Bit07	Bit06	Bit05	Bit04	Bit03	Bit02	Bit01	Bit00	
Linear speed	Length value	Count value	feedback speed	Auxiliary frequency display	Main frequency display	Load speed display	PID output	
Bit15	Bit14	Bit13	Bit12	Bit11	Bit10	Bit09	Bit08	
Reserved	Communication setting value	PLC stage	Remaining running time	Output current percentage	Overload count	Current running time	Current power-on time	

F8.05	LED display stop parameters			Range:0x0000~0xFFFF			Default:0x0033	
Bit07	Bit06	Bit05	Bit04	Bit03	Bit02	Bit01	Bit00	
Count value	AI3 voltage	AI2 voltage	AI1 voltage	Digital output status	X input status	Bus voltage	Set frequency	
Bit15	Bit14	Bit13	Bit12	Bit11	Bit10	Bit09	Bit08	
			Pulse setting frequency	PID setting	Load speed	PLC stage	Length value	



F8.06	Load speed display coefficient	Range:0.0001~6.5000	Default:1.0000
-------	--------------------------------	---------------------	----------------

This parameter is used to adjust the relationship between the output frequency of the inverter and the load speed. For details, see the description of F8.12.

F8.07	temperature of IGBT	Range:0.0°C~100.0°C	Default:-
-------	---------------------	---------------------	-----------

It is used to display the insulated gate bipolar transistor (IGBT) temperature of the Inverter module, and the IGBT overheat protection value of the Inverter module depends on the model.

F8.09	Accumulative running time	Range:0~65535	Default:-
-------	---------------------------	---------------	-----------

It is used to display the accumulative running time of the inverter. After the accumulative running time reaches the value set in F4.17, the terminal with the digital output function 12 becomes ON.

F8.12	Number of decimal places for load speed display	Range:0~3	Default:1
-------	---	-----------	-----------

F8.12 is used to set the number of decimal places for load speed display. The following gives an example to explain how to calculate the load speed:

Assume that F8.06 (Load speed display coefficient) is 2.000 and F8.12 is 2 (2 decimal places). When the running frequency of the inverter is 40.00 Hz, the load speed is  $40.00 \times 2.000 = 80.00$ . If the inverter is at the stop state, the load speed is the speed corresponding to the set frequency, namely, "set load speed". If the set frequency is 50.00 Hz, the load speed in the stop state is  $50.00 \times 2.000 = 100.0000$ : 0 decimal place

- 1: 1 decimal place
- 2: 2 decimal places
- 3: 3 decimal places

F8.13	Accumulative power-on time	Range:0~65535h	Default:-
-------	----------------------------	----------------	-----------

It is used to display the accumulative power-on time of the inverter since the delivery. If the time reaches the set power-on time (F4.17), the terminal with the digital output function 24 becomes ON.

F8.14	Accumulative power consumption	Range:0~65535kwh	Default:-
-------	--------------------------------	------------------	-----------

It is used to display the accumulative power consumption of the inverter until now.

### Group F9: Fault and Protection

F9.00	Motor overload protection selection	Range:0~1	Default:1
-------	-------------------------------------	-----------	-----------

F9.01	Motor overload protection gain	Range:0.20~10.00	Default:1.00
-------	--------------------------------	------------------	--------------

F9.00 = 0: The motor overload protection is disabled. In this case, install a thermal relay between the AC drive output (U, V, W) and the motor.

F9.00 = 1: The motor overload protection function has an inverse load-time characteristics. If the motor overload current level and overload protection time need be adjusted, modify setting of F9.01.

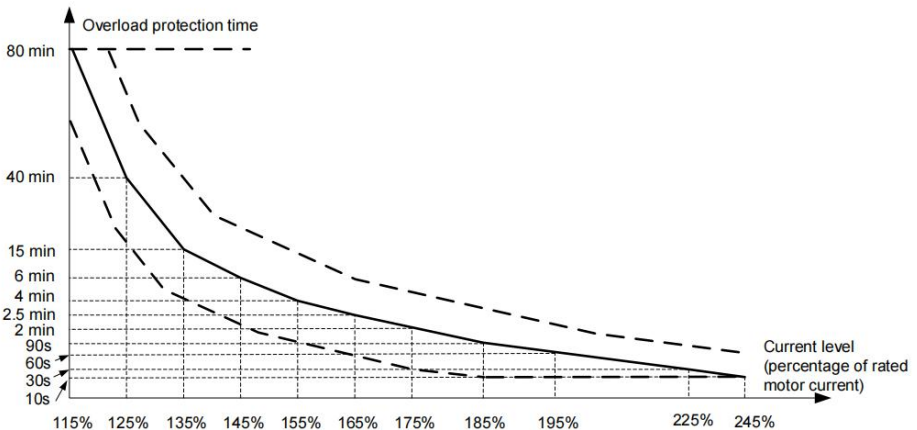

When motor running current reaches 175% of rated motor current and motor runs at this level for 2 minutes, Err11 (motor overload) is detected. When motor running current reaches 115% of rated motor current and motor runs at this level for 80 minutes, Err11 is detected.

Suppose that rated motor current is 100 A.

- F9.01 = 1.00: According to the Figure , when motor running current reaches 125 A (125% of 100 A) and motor runs at 125 A for 40 minutes, Err11 is detected.
- F9-01 = 1.20: According to the Figure, when motor running current reaches 125 A (125% of 100 A) and motor runs at 125 A for  $40 \times 1.2 = 48$  minutes,Err11 is detected.

F9.02	Motor overload warning coefficient	Range:50~100	Default:80%
-------	------------------------------------	--------------	-------------

The AC drive has the motor overload pending function that reminds of motor overload in advance through digital output function 6. On the condition that F9.01 = 1.00 and F9.02 = 80%, when motor running current reaches 145% of rated motor current and motor runs at this level for  $80\% \times 6 = 4.8$  minutes, DO terminal or fault relay outputs the motor overload pending signal.

When F9.02 = 100%, the motor overload pending and the motor overload protection are performed simultaneously.

F9.07	Short-circuit to ground upon power-on	Range:0~1	Default:1
-------	---------------------------------------	-----------	-----------

- 0: Disabled
- 1: Enabled

It is used to determine whether to check the motor is short-circuited to ground at power-on of the inverter. If this function is enabled, the inverter's UVW will have voltage output a while after power-on.

F9.09	Fault auto reset times	Range:0~20	Default:0
-------	------------------------	------------	-----------

This function parameter sets permissible times of auto fault reset. If reset times exceed the value set in this parameter, the inverter will keep fault status.

Undervoltage (Err09) is reset automatically when bus voltage recovers to normal. It is not included in auto reset times.

Short-circuit to ground (Err23) cannot be reset automatically or manually. It can only be reset after power down.

F9.10	Selection of DO action during auto reset	Range:0~1	Default:0
-------	--	-----------	-----------

- 0: Not act
- 1: Act

This function parameter decides whether digital output terminal set for fault output acts during the fault reset.

F9.11	Time interval of fault auto reset	Range:0.1s~100.0s	Default:1.0s
-------	-----------------------------------	-------------------	--------------

It is used to set the waiting time from the alarm of the inverter to fault auto reset.

F9.12	Input phase loss protection/contactor energizing protection selection	Range:0~11	Default:10
-------	---	------------	------------

- Unit's digit: Input phase loss protection
- Ten's digit: Contactor energizing protection
- 0: Disabled
- 1: Enabled

It is used to determine whether to perform input phase loss or contactor energizing protection. When F9.12 = 1, only the three-phase 380V, 018G and above models have the fault.

F9.13	Output phase loss protection selection	Range:0~1	Default:1
-------	--	-----------	-----------

- It is used to determine whether to perform output phase loss protection.
- 0: Disabled
- 1: Enabled

F9.47	Fault protection action selection 1		Range:0000~2222	Default:0000	
Ten thousand's digit(Communication fault, Err16)	Thousand's digit (External equipment fault, Err15)	Hundred's digit (Power output phase loss, Err13)	Ten's digit (Power input phase loss, Err12)	Unit's digit : (Motor overload, Err11)	
0: Coast to stop 1:Stop according to the stop mode 2: Continue to run	0: Coast to stop 1:Stop according to the stop mode 2: Continue to run	0: Coast to stop 1:Stop according to the stop mode 2: Continue to run	0: Coast to stop 1:Stop according to the stop mode 2: Continue to run	0: Coast to stop 1:Stop according to the stop mode 2: Continue to run	
F9.48	Fault protection action selection 2		Range:0000~2222	Default:0000	
Ten thousand's digit(accumulative running time reached) 0: Coast to stop 1:Stop according to the stop mode 2: Continue to run	Thousand's digit: reserved	Hundred's digit: reserved	Ten's digit (EEPROM read-write fault, Err21) 0: Coast to stop 1:Stop according to the stop mode 2: Continue to run	Unit's digit (Encoder fault, Err20) 0: Coast to stop 1:Stop according to the stop mode 2:Continue to run	
F9.49	Fault protection action selection 3		Range:0000~2222	Default:0000	
Ten thousand's digit (PID feedback lost during running)	Thousand's digit (Load becoming 0, Err30)	Hundred's digit (Accumulative power-on time reached, Err29)	Ten's digit (User-defined fault 2, Err28)	Unit's digit (User-defined fault 1,Err27)	
0: Coast to stop 1:Stop according to the stop mode 2:Continue to run	0: Coast to stop 1: Stop according to the stop mode 2: Continue to run at 7% of rated motor frequency and resume to the set frequency if the load recovers	0: Coast to stop 1:Stop according to the stop mode 2: Continue to run	0:Coast to stop 1:Stop according to the stop mode 2: Continue to run	0:Coast to stop 1:Stop according to the stop mode 2:Continue to run	

- 0: Coast to stop inverter displays Err \*\*, and directly down
- 1: Stop according to the stop mode Drive Show A \*\*, then stop mode, the display Err \*\* after the shutdown.
- 2: Continue to run The drive continues to run and display A \*\*, the operating frequency is set by F9.54.

F9.50	Fault protection action selection 4	Range:000~222	Default:000
Ten's digit (Motor over-speed,Err43)		Unit's digit (Too large speed deviation,Err42)	
0: Coast to stop 1:Stop according to the stop mode 2: Continue to run		0: Coast to stop 1:Stop according to the stop mode 2: Continue to run	

F9.54	Frequency selection for continuing to run upon fault	Range:0~4	Default:0
0: Current running frequency			
1: Set frequency			
2: Frequency upper limit			
3: Frequency lower limit			
4: Backup frequency upon abnormality			

F9.55	Backup frequency upon abnormality	Range:60.0%~100.0%	Default:100.0%
-------	-----------------------------------	--------------------	----------------

If a fault occurs during the running of the inverter and the handling of fault is set to "Continue to run", the inverter displays A\*\* and continues to run at the frequency set in F9.54.

The setting of F9.55 is a percentage relative to the maximum frequency.

F9.59	Action selection at instantaneous power failure	Range:0~2	Default:0
F9.60	Action pause judging voltage at instantaneous power failure	Range:80.0%~100.0%	Default:90.0%
F9.61	Voltage rally judging time at instantaneous power failure	Range:0.00s~100.00s	Default:0.50s
F9.62	Action judging voltage at instantaneous power failure	Range:60.0%~100.0%	Default:80.0%

Upon instantaneous power failure or sudden voltage dip, the DC bus voltage of the inverter reduces. This function enables the inverter to compensate the DC bus voltage reduction with the load feedback energy by reducing the output frequency so as to keep the inverter running continuously.

If F9.59 = 1, upon instantaneous power failure or sudden voltage dip, the inverter decelerates. Once the bus voltage resumes to normal, the inverter accelerates to the set frequency. If the bus voltage remains normal for the time exceeding the value set in F9.61, it is considered that the bus voltage resumes to normal.

If F9.59 = 2, upon instantaneous power failure or sudden voltage dip, the inverter decelerates to stop.

F9.63	Protection upon load becoming 0	Range:0~1	Default:0
F9.64	Detection level of load becoming 0	Range:0.0%~100.0%	Default:10.0%
F9.65	Detection time of load becoming 0	Range:0.0s~60.0s	Default:1.0s

If protection upon load becoming 0 is enabled, when the output current of the inverter is lower than the detection level (F9.64) and the lasting time exceeds the detection time (F9.65), the output frequency of the inverter automatically declines to 7% of the rated frequency. During the protection, the inverter automatically accelerates to the set frequency if the load resumes to normal.

F9.67	Over-speed detection value	Range:0.0%~50.0%(max.freq)	Default:20.0%
F9.68	Over-speed detection time	Range:0.0s~60.0s	Default:5.0s

This function is valid only when the inverter runs in the FVC mode.

If the actual motor rotational speed detected by the inverter exceeds the maximum frequency and the excessive value is greater than the value of F9.67 and the lasting time exceeds the value of F9.68, the inverter reports Err43 and acts according to the selected fault protection action.

If the over-speed detection time is 0.0s, the over-speed detection function is disabled.

F9.69	Detection value of too large speed deviation	Range:0.0%~50.0%(maximum frequency)	Default:20.0%
F9.70	Detection time of too large speed deviation	Range:0.0s~60.0s	Default:0.0s

This function is valid only when the inverter runs in the CLVC mode.

If the inverter detects the deviation between the actual motor rotational speed detected by the inverter and the set frequency is greater than the value of F9.69 and the lasting time exceeds the value of F9.70, the inverter reports Err42 and according to the selected fault protection action.

If F9.70 (Detection time of too large speed deviation) is 0.0s, this function is disabled.

## Group FA: Process Control PID Function

FA.00	PID setting source	Range:0~6	Default:0
FA.01	PID digital setting	Range:0.0%~100.0%	Default:50.0%

FA.00 is used to select the channel of target process PID setting. The PID setting is a relative value and ranges from 0.0% to 100.0%. The PID feedback is also a relative value. The purpose of PID control is to make the PID setting and PID feedback equal.

- 0: FA-01
- 1: AI1
- 2: AI2
- 3: AI3
- 5: Communication setting
- 6: Multi-reference

FA.02	PID feedback source	Range:0~8	Default:0
-------	---------------------	-----------	-----------

This parameter is used to select the feedback signal channel of process PID.

- 0: AI1
- 1: AI2
- 2: AI3
- 3: AI1 - AI2
- 4: Pulse setting (DI5)
- 5: Communication setting
- 6: AI1 + AI2
- 7: MAX (AI1, AI2)
- 8: MIN (AI1, AI2)

FA.03	PID action direction	Range:0~1	Default:0
-------	----------------------	-----------	-----------

- 0: Forward action

When the feedback value is smaller than the PID setting, the inverter's output frequency rises. For example, the winding tension control requires forward PID action.

- 1: Reverse action

When the feedback value is smaller than the PID setting, the inverter's output frequency reduces. For example, the unwinding tension control requires reverse PID action.

Note that this function is influenced by the DI function 35 "Reverse PID action direction".

FA.04	PID setting feedback range	Range:0~65535	Default:1000
-------	----------------------------	---------------	--------------

This parameter is a non-dimensional unit. It is used for PID setting display (H0.14) and PID feedback display (H0.15).

Relative value 100% of PID setting feedback corresponds to the value of FA.04. If FA-04 is set to 2000 and PID setting is 100.0%, the PID setting display (H0.14) is 2000.

FA.05	Proportional gain Kp1	Range:0.0~100.0	Default:20
FA.06	Integral time Ti1	Range:0.01s~10.00s	Default:2.00s
FA.07	Differential time Td1	Range:0.000s~10.000s	Default:0.000s

Proportional gain Kp1:

It decides the regulating intensity of the PID regulator. The higher the Kp1 is, the larger the regulating intensity is. The value 100.0 indicates when the deviation between PID feedback and PID setting is 100.0%, the adjustment amplitude of the PID regulator on the output frequency reference is the maximum frequency.

Integral time Ti1:

It decides the integral regulating intensity. The shorter the integral time is, the larger the regulating intensity is. When the deviation between PID feedback and PID setting is 100.0%, the integral regulator performs continuous adjustment for the time set in FA.06. Then the adjustment amplitude reaches the maximum frequency.

Differential time Td1:

It decides the regulating intensity of the PID regulator on the deviation change. The longer the differential time is, the larger the regulating intensity is. Differential time is the time within which the feedback value change reaches 100.0%, and then the adjustment amplitude reaches the maximum frequency.

FA.08	Cut-off frequency of PID reverse rotation	Range:0.00 to max. freq	Default:2.00Hz
-------	---	-------------------------	----------------

In some situations, only when the PID output frequency is a negative value (inverter reverse rotation), PID setting and PID feedback can be equal. However, too high reverse rotation frequency is prohibited in some applications, and FA-08 is used to determine the reverse rotation frequency upper limit.

FA.09	PID deviation limit	Range:0.00%~100.0%	Default:0.0%
-------	---------------------	--------------------	--------------

If the deviation between PID feedback and PID setting is smaller than the value of FA.09, PID control stops. The small deviation between PID feedback and PID setting will make the output frequency stabilize, effective for some closed-loop control applications.

FA.10	PID differential limit	Range:0.00%~100.00%	Default:0.10%
-------	------------------------	---------------------	---------------

It is used to set the PID differential output range. In PID control, the differential operation may easily cause system oscillation. Thus, the PID differential regulation is restricted to a small range.

FA.11	PID setting change time	Range:0.00~650.00s	Default:0.00s
-------	-------------------------	--------------------	---------------

The PID setting change time indicates the time required for PID setting changing from 0.0% to 100.0%. The PID setting changes linearly according to the change time, reducing the impact caused by sudden setting change on the system.

FA.12	PID feedback filter time	Range:0.00~60.00s	Default:0.00s
FA.13	PID output filter time	Range:0.00~60.00s	Default:0.00s

FA.12 is used to filter the PID feedback, helping to reduce interference on the feedback but slowing the response of the process closed-loop system.

FA.13 is used to filter the PID output frequency, helping to weaken sudden change of the inverter output frequency but slowing the response of the process closed-loop system.

FA.15	Proportional gain Kp2	Range:0.0~100.0	Default:20.0
FA.16	Integral time Ti2	Range:0.01s~10.00s	Default:2.00s
FA.17	Differential time Td2	Range:0.000s~10.000s	Default:0.000s
FA.18	PID parameter switchover condition	Range:0~2	Default:0
FA.19	PID parameter switchover deviation 1	Range:0.0%~FA.20	Default:20.0%
FA.20	PID parameter switchover deviation 2	Range:FA.19~100.0%	Default:80.0%

FA-15 to FA-20: On some applications, switchover to another set of PID parameters may be required to fine tune the overall performance as load conditions can vary during the different machine cycles. These parameters are used for switchover between two groups of PID parameters. Switchover can be implemented via a DI terminal or automatically implemented according to PID error level..

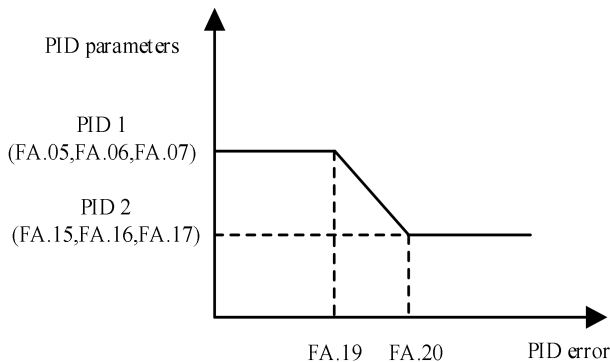

FA.21	PID initial value	Range:0.0%~100.0%	Default:0.0%
FA.22	PID initial value holding time	Range:0.00~650.00s	Default:0.00s

When the inverter starts up, the PID starts closed-loop algorithm only after the PID output is fixed to the PID initial value (FA.21) and lasts the time set in FA.22.

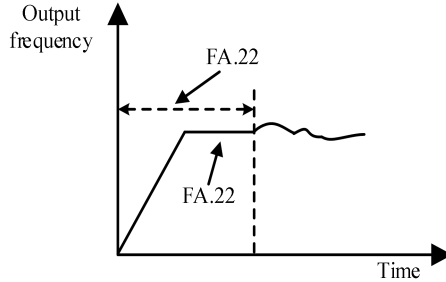

FA.23	Maximum deviation between two PID outputs in forward direction	Range:0.00%~100.00%	Default:1.00%
FA.24	Maximum deviation between two PID outputs in reverse direction	Range:0.00%~100.00%	Default:1.00%

This function is used to limit the deviation between two PID outputs (2 ms per PID output) to suppress the rapid change of PID output and stabilize the running of the inverter.

FA.23 and FA.24 respectively correspond to the maximum absolute value of the output deviation in forward direction and in reverse direction.

FA.25	PID integral property	Range:11	Default:00
-------	-----------------------	----------	------------

Unit's digit (Integral separated)

0: Invalid

1: Valid

If it is set to valid, the PID integral operation stops when the X allocated with function 38 "PID integral pause" is ON. In this case, only proportional and differential operations take effect.

If it is set to invalid, integral separated remains invalid no matter whether the X allocated with function 38 "PID integral pause" is ON or not.

Ten's digit (Whether to stop integral operation when the output reaches the limit)

0: Continue integral operation

1: Stop integral operation

Whether to stop integral operation when the output reaches the limit

If "Stop integral operation" is selected, the PID integral operation stops, which may help to reduce the PID overshoot.

FA.26	Detection value of PID feedback loss	Range:0.0%: Not judging feedback loss 0.1%~100.0%	Default:0.0%
FA.27	Detection time of PID feedback loss	Range:0.0s~20.0s	Default:0.0s

These parameters are used to judge whether PID feedback is lost.

If the PID feedback is smaller than the value of FA.26 and the lasting time exceeds the value of FA.27, the inverter reports Err31 and acts according to the selected fault protection action.

FA.28	PID operation at stop	0: No PID operation at stop 1: PID operation at stop	0
-------	-----------------------	---	---

It is used to select whether to continue PID operation in the state of stop. Generally, the PID operation stops when the inverter stops.

## Group FB: Swing Frequency, Fixed Length ,Count and Torque Control

The swing frequency function is applied to the textile and chemical fiber fields and the applications where traversing and winding functions are required.

The swing frequency function indicates that the output frequency of the inverter swings up and down with the set frequency as the center. The trace of running frequency at the time axis is shown in the Figure .

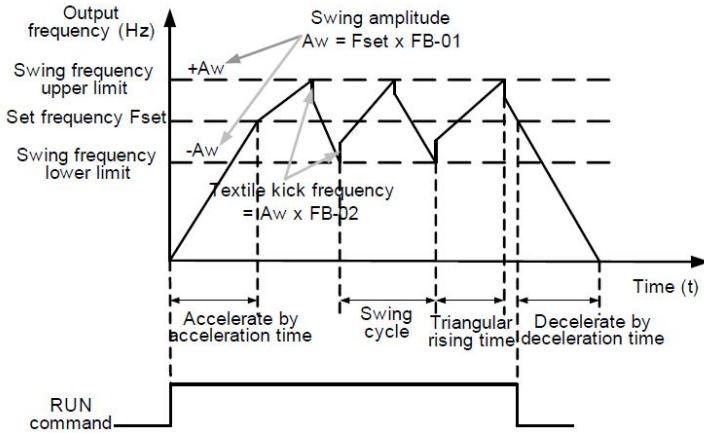

Fb.00	Swing frequency setting mode	Range:0~1	Default:0
-------	------------------------------	-----------	-----------

This parameter is used to select the base value of the swing amplitude.

0: Relative to the central frequency (F0.07 frequency source selection)

It is variable swing amplitude system. The swing amplitude varies with the central frequency (set frequency).

1: Relative to the maximum frequency (F0.10 maximum output frequency)

It is fixed swing amplitude system. The swing amplitude is fixed.

Fb.01	Swing frequency amplitude	Range:0.0%~100.0%	Default:0.0%
Fb.02	Jump frequency amplitude	Range:0.0%~50.0%	Default:0.0%

This parameter is used to determine the swing amplitude and jump frequency amplitude. The swing frequency is limited by the frequency upper limit and frequency lower limit.

- If relative to the central frequency (Fb.00 = 0), the actual swing amplitude AW is the calculation result of F0.07 (Frequency source selection) multiplied by FB.01.

- If relative to the maximum frequency (Fb.00 = 1), the actual swing amplitude AW is the calculation result of F0.10 (Maximum frequency) multiplied by FB.01.

Jump frequency = Swing amplitude AW \* Fb.02 (Jump frequency amplitude).

- If relative to the central frequency (Fb.00 = 0), the jump frequency is a variable value.

- If relative to the maximum frequency (Fb.00 = 1), the jump frequency is a fixed value.

The swing frequency is limited by the frequency upper limit and frequency lower limit.

Fb.03	Swing frequency cycle	Range:0.1s~3000.0s	Default:10.0s
Fb.04	Triangular wave rising time coefficient	Range:0.1%~100.0%	Default:50.0%

FB.03 specifies the time of a complete swing frequency cycle.

FB.04 specifies the time percentage of triangular wave rising time to FB.03 (Swing frequency cycle).

- Triangular wave rising time = FB.03 (Swing frequency cycle) \* FB.04 (Triangular wave rising time coefficient, unit: s)

- Triangular wave falling time = FB.03 (Swing frequency cycle) \* (1 - FB.04 Triangular wave rising time coefficient ,unit: s)



Fb.05	Set length	Range:0m~65535m	Default:1000m
Fb.06	Actual length	Range:0m~65535m	Default:0m
Fb.07	Number of pulses per meter	Range:0.1~6553.5	Default:100.0

The preceding parameters are used for fixed length control.

The length information is collected by X terminals. Fb.06 (Actual length) is calculated by dividing the number of pulses collected by the X terminal by Fb.07 (Number of pulses each meter).

When the actual length Fb.06 exceeds the set length in Fb.05, the output terminal allocated with function 10 (Length reached) becomes ON.

During the fixed length control, the length reset operation can be performed via the X terminal allocated with function 28. For details, see the descriptions of F4.00 to F4.09.

Allocate corresponding X terminal with function 27 (Length count input) in applications. If the pulse frequency is high, X5 must be used.

Fb.08	Set count value	Range:1~65535	Default:1000
Fb.09	Designated count value	Range:1~65535	Default:1000

The count value needs to be collected by X terminal. Allocate the corresponding X terminal with function 25 (Counter input) in applications. If the pulse frequency is high, X5 must be used.

When the count value reaches the set count value (Fb.08), the output terminal allocated with function 8 (Set count value reached) becomes ON. Then the counter stops counting.

When the counting value reaches the designated counting value (Fb.09), the output terminal allocated with function 9 (Designated count value reached) becomes ON. Then the counter continues to count until the set count value is reached.

Fb.09 should be equal to or smaller than Fb.08.

Fb.10	Speed/Torque control selection	Range:0~1	Default:0
-------	--------------------------------	-----------	-----------

It is used to select the inverter's control mode: speed control or torque control.

0: speed control

1: torque control, when using this mode, you need to set F0.01 to 0.

The AT550 provides DI terminals with two torque related functions, function 29 (Torque control prohibited) and function 46 (Speed control/Torque control switchover). The two DI terminals need to be used together with A0.00 to implement speed control/torque control switchover. If the DI terminal allocated with function 46 (Speed control/Torque control switchover) is OFF, the control mode is determined by Fb.00. If the DI terminal allocated with function 46 is ON, the control mode is reverse to the value of Fb.00.

However, if the DI terminal with function 29 (Torque control prohibited) is ON, the inverter is fixed to run in the speed control mode.

Fb.11	Torque setting source in torque control	Range:0~7	Default:0
Fb.12	Torque digital setting in torque control	Range:-200.0%~200.0%	Default:150.0%

Fb.11 is used to set the torque setting source. There are a total of eight torque setting sources.

The torque setting is a relative value. 100.0% corresponds to the inverter's rated torque. The setting range is -200.0% to 200.0%, indicating the inverter's maximum torque is twice of the inverter's rated torque.

If the torque setting is positive, the inverter rotates in forward direction. If the torque setting is negative, the inverter rotates in reverse direction.

- 1: Digital setting (Fb.12) : The target torque directly uses the value set in Fb.12.
- 2: AI1
- 3: AI2
- 4: AI3
- 5: Pulse setting (DI5)
- 6: Communication setting

The target torque is set by means of communication.

The data format is -100.00% to 100.00%. 100% corresponds to the value of Fb.12.

Fb.13	Forward max.freq in torque control	Range:0.00Hz to maximum frequency	Default:50.00Hz
Fb.14	Reverse max.freq in torque control	Range:0.00Hz to maximum frequency	Default:50.00Hz

Two parameters are used to set the max. freq in forward or reverse rotation in torque control mode.

In torque control, if the load torque is smaller than the motor output torque, the motor's rotational speed will rise continuously. To avoid runaway of the mechanical system, the motor maximum rotating speed must be limited in torque control.

You can implement continuous change of the maximum frequency in torque control dynamically by controlling the frequency upper limit.

Fb.15	Acceleration time in torque control	Range:0.00s~65000s	Default:0.00s
Fb.16	Deceleration time in torque control	Range:0.00s~65000s	Default:0.00s

In torque control, the difference between the motor output torque and the load torque determines the speed change rate of the motor and load. The motor rotational speed may change quickly and this will result in noise or too large mechanical stress. The setting of acceleration/deceleration time in torque control makes the motor rotational speed change softly.

However, in applications requiring rapid torque response, set the acceleration/deceleration time in torque control to 0.00s. For example, two inverters are connected to drive the same load. To balance the load allocation, set one inverter as master in speed control and the other as slave in torque control. The slave receives the master's output torque as the torque command and must follow the master rapidly. In this case, the acceleration/deceleration time of the slave in torque control is set to 0.0s.

### Group FC: Multi-Reference and Simple PLC Function Parameters

FC.00	Reference 0	Range:-100.0%~100.0%	Default:0.0%
FC.01	Reference 1	Range:-100.0%~100.0%	Default:0.0%
FC.02	Reference 2	Range:-100.0%~100.0%	Default:0.0%
FC.03	Reference 3	Range:-100.0%~100.0%	Default:0.0%
FC.04	Reference 4	Range:-100.0%~100.0%	Default:0.0%
FC.05	Reference 5	Range:-100.0%~100.0%	Default:0.0%
FC.06	Reference 6	Range:-100.0%~100.0%	Default:0.0%
FC.07	Reference 7	Range:-100.0%~100.0%	Default:0.0%
FC.08	Reference 8	Range:-100.0%~100.0%	Default:0.0%
FC.09	Reference 9	Range:-100.0%~100.0%	Default:0.0%
FC.10	Reference10	Range:-100.0%~100.0%	Default:0.0%
FC.11	Reference11	Range:-100.0%~100.0%	Default:0.0%
FC.12	Reference12	Range:-100.0%~100.0%	Default:0.0%
FC.13	Reference13	Range:-100.0%~100.0%	Default:0.0%
FC.14	Reference14	Range:-100.0%~100.0%	Default:0.0%
FC.15	Reference15	Range:-100.0%~100.0%	Default:0.0%

Multi-reference can be the setting source of frequency, V/F separated voltage and process PID. The multi-reference is relative value and ranges from -100.0% to 100.0%.

As frequency source, it is a percentage relative to the maximum frequency. As V/F separated voltage source, it is a percentage relative to the rated motor voltage. As process PID setting source, it does not require conversion.

Multi-reference can be switched over based on different states of DI terminals. For details, see the descriptions of group F2.

FC.16	Simple PLC running mode	Range:0~2	Default:0
-------	-------------------------	-----------	-----------

- 0: Stop after the inverter runs one cycle
- 1: Keep final values after the inverter runs one cycle
- 2: Repeat after the inverter runs one cycle

When simple PLC is used as the frequency source, whether parameter values of FC.00 to FC.15 are positive or negative determines the running direction. If the parameter values are negative, it indicates that the inverter runs in reverse direction.

FC.17	Simple PLC retentive selection	Range:00~11	Default:00
-------	--------------------------------	-------------	------------

PLC retentive upon power failure indicates that the inverter memorizes the PLC running moment and running frequency before power failure and will continue to run from the memorized moment after it is powered on again. If the unit's digit is set to 0, the inverter restarts the PLC process after it is powered on again.

PLC retentive upon stop indicates that the inverter records the PLC running moment and running frequency upon stop and will continue to run from the recorded moment after it starts up again. If the ten's digit is 0, the inverter restarts the PLC process after it starts up again.

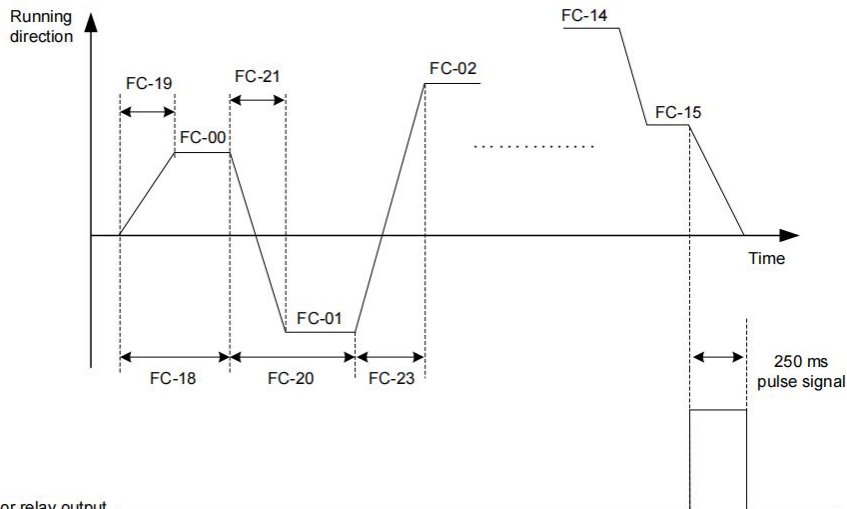

DO or relay output

FC.17	Simple PLC retentive selection	Range:00~11	Default:00
-------	--------------------------------	-------------	------------

0: Not retentive

1: Retentive

Unit position: Retentive at power down

Tens position: Retentive at stop

FC.18	Running time of simple PLC reference 0	Range: 0.0s (h) ~6553.5s (h)	Default:0.0s (h)
FC.19	Acceleration/deceleration time of simple PLC reference 0	Range:0~3	Default:0
FC.20	Running time of simple PLC reference 1	Range: 0.0s (h) ~6553.5s (h)	Default:0.0s (h)
FC.21	Acceleration/deceleration time of simple PLC reference 1	Range:0~3	Default:0
FC.22	Running time of simple PLC reference 2	Range: 0.0s (h) ~6553.5s (h)	Default:0.0s (h)
FC.23	Acceleration/deceleration time of simple PLC reference 2	Range:0~3	Default:0
FC.24	Running time of simple PLC reference 3	Range: 0.0s (h) ~6553.5s (h)	Default:0.0s (h)
FC.25	Acceleration/deceleration time of simple PLC reference 3	Range:0~3	Default:0
FC.26	Running time of simple PLC reference 4	Range: 0.0s (h) ~6553.5s (h)	Default:0.0s (h)

FC.27	Acceleration/deceleration time of simple PLC reference 4	Range:0~3	Default:0
FC.28	Running time of simple PLC reference 5	Range: 0.0s (h) ~6553.5s (h)	Default:0.0s (h)
FC.29	Acceleration/deceleration time of simple PLC reference 5	Range:0~3	Default:0
FC.30	Running time of simple PLC reference 6	Range: 0.0s (h) ~6553.5s (h)	Default:0.0s (h)
FC.31	Acceleration/deceleration time of simple PLC reference 6	Range:0~3	Default:0
FC.32	Running time of simple PLC reference 7	Range: 0.0s (h) ~6553.5s (h)	Default:0.0s (h)
FC.33	Acceleration/deceleration time of simple PLC reference 7	Range:0~3	Default:0
FC.34	Running time of simple PLC reference 8	Range: 0.0s (h) ~6553.5s (h)	Default:0.0s (h)
FC.35	Acceleration/deceleration time of simple PLC reference 8	Range:0~3	Default:0
FC.36	Running time of simple PLC reference 9	Range: 0.0s (h) ~6553.5s (h)	Default:0.0s (h)
FC.37	Acceleration/deceleration time of simple PLC reference 9	Range:0~3	Default:0
FC.38	Running time of simple PLC reference 10	Range: 0.0s (h) ~6553.5s (h)	Default:0.0s (h)
FC.39	Acceleration/deceleration time of simple PLC reference 10	Range:0~3	Default:0
FC.40	Running time of simple PLC reference 11	Range: 0.0s (h) ~6553.5s (h)	Default:0.0s (h)
FC.41	Acceleration/deceleration time of simple PLC reference 11	Range:0~3	Default:0
FC.42	Running time of simple PLC reference 12	Range: 0.0s (h) ~6553.5s (h)	Default:0.0s (h)
FC.43	Acceleration/deceleration time of simple PLC reference 12	Range:0~3	Default:0
FC.44	Running time of simple PLC reference 13	Range: 0.0s (h) ~6553.5s (h)	Default:0.0s (h)
FC.45	Acceleration/ deceleration time of simple PLC reference 13	Range:0~3	Default:0
FC.46	Running time of simple PLC reference 14	Range: 0.0s (h) ~6553.5s (h)	Default:0.0s (h)
FC.47	Acceleration/deceleration time of simple PLC reference 14	Range:0~3	Default:0
FC.48	Running time of simple PLC reference 15	Range: 0.0s (h) ~6553.5s (h)	Default:0.0s (h)
FC.49	Acceleration/deceleration time of simple PLC reference 15	Range:0~3	Default:0
FC.50	Time unit of simple PLC running	Range:0~1	Default:0
FC.51	Reference 0 source	Range:0~6	Default:0

FC-50 sets running time unit in simple PLC mode. FC-51 selects the setting channel of reference 0.

**Group FD: User-defined Parameters**

Reference to Appendix A: MODBUS Communication Protocol

**Group FE:Quick Menu parameters**

FE.00	Quick Menu 0	F0.00~FF.xx P0.00~P1.xx H0.00~H0.xx	Default:F0.10
FE.01	Quick Menu 1		Default:F0.02
FE.02	Quick Menu 2		Default:F0.03
FE.03	Quick Menu 3		Default:F0.07
FE.04	Quick Menu 4		Default:F0.08
FE.05	Quick Menu 5		Default:F0.17
FE.06	Quick Menu 6		Default:F0.18
FE.07	Quick Menu 7		Default:F3.00
FE.08	Quick Menu 8		Default:F3.01
FE.09	Quick Menu 9		Default:F4.00
FE.10	Quick Menu 10		Default:F4.01
FE.11	Quick Menu 11		Default:F4.02
FE.12	Quick Menu 12		Default:F5.04
FE.13	Quick Menu 13		Default:F5.07
FE.14	Quick Menu 14		Default:F6.00
FE.15	Quick Menu 15		Default:F6.10
FE.16	Quick Menu 16		Default:F0.00
FE.17	Quick Menu 17		Default:F0.00
FE.18	Quick Menu 18		Default:F0.00
FE.19	Quick Menu 19		Default:F0.00
FE.20	Quick Menu 20		Default:F0.00
FE.21	Quick Menu 21		Default:F0.00
FE.22	Quick Menu 22		Default:F0.00
FE.23	Quick Menu 23		Default:F0.00
FE.25	Quick Menu 24		Default:F0.00
FE.26	Quick Menu 24		Default:F0.00
FE.27	Quick Menu 24		Default:F0.00
FE.28	Quick Menu 24		Default:F0.00
FE.29	Quick Menu 24		Default:F0.00

FE is user-defined parameter group. You can select the required parameters from all AT550 functions codes and add them into this group, convenient for view and modification.

Group FE provides a maximum of 30 user-defined parameters. If "FE.00" is displayed,it indicates that group FE is null. After you enter Quick Menu mode, the displayed parameters are defined by FE.00 to FE.29 and the sequence is consistent with that in group FE.

**Group P0:Analog four points offset parameters**

P0.00	AI curve 4 minimum input	Range:-10.00V~P0.02	Default:0.00V
P0.01	Corresponding setting of AI curve 4 minimum input	Range:-100.0%~+100.0%	Default:0.0%
P0.02	AI curve 4 inflexion 1 input	Range:P0.00~P0.04	Default:3.00V
P0.03	Corresponding setting of AI curve 4 inflexion 1 input	Range:-100.0%~+100.0%	Default:30.0%
P0.04	AI curve 4 inflexion 1 input	Range:P0.02~P0.06	Default:6.00V
P0.05	Corresponding setting of AI curve 4 inflexion 1 input	Range:-100.0%~+100.0%	Default:60.0%
P0.06	AI curve 4 maximum input	Range:P0.06~+10.00V	Default:10.00V

P0.07	Corresponding setting of AI curve 4 maximum input	Range:-100.0%~+100.0%	Default:100.0%
P0.08	AI curve 5 minimum input	Range:-10.00V~P0.10	Default:-10.00V
P0.09	Corresponding setting of AI curve 5 minimum input	Range:-100.0%~+100.0%	Default:-100.0%
P0.10	AI curve 5 inflexion 1 input	Range:P0.08~P0.12	Default:-3.00V
P0.11	Corresponding setting of AI curve 5 inflexion 1 input	Range:-100.0%~+100.0%	Default:-30.0%
P0.12	AI curve 5 inflexion 1 input	Range:P0.10~P0.14	Default:3.00V
P0.13	Corresponding setting of AI curve 5 inflexion 1 input	Range:-100.0%~+100.0%	Default:30.0%
P0.14	AI curve 5 maximum input	Range:P0.12~+10.00V	Default:10.00V
P0.15	Corresponding setting of AI curve 5 maximum input	Range:-100.0%~+100.0%	Default:100.0%

P0.00 to P0.15 define AI curve 4 and AI curve 5, which have the similar function of AI curve 1 to AI curve 3. AI curve 1 to AI curve 3 are linear correspondence and AI curve 4 and AI curve 5 are four-point correspondence.

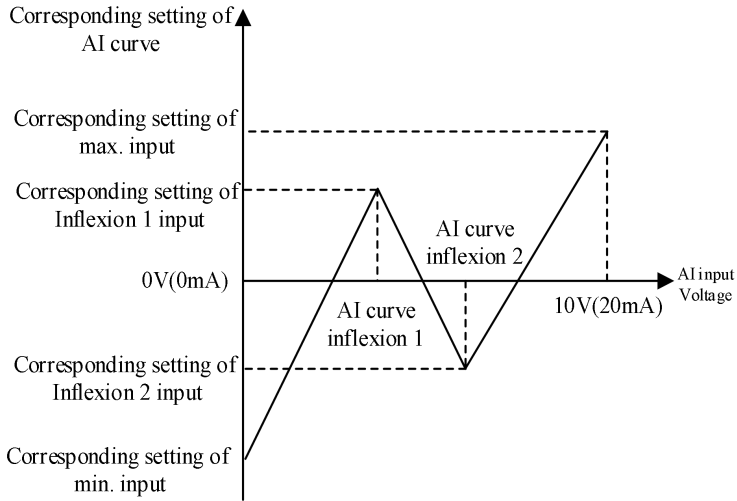

**Group P1: Analog calibration parameters**

P1.00	AI1 measured voltage 1	Range:0.500V~4.000V	Factory corrected
P1.01	AI1 displayed voltage 1	Range:0.500V~4.000V	Factory corrected
P1.02	AI1 measured voltage 2	Range:6.000V~9.999V	Factory corrected
P1.03	AI1 displayed voltage 2	Range:6.000V~9.999V	Factory corrected
P1.04	AI2 measured voltage 1	Range:0.500V~4.000V	Factory corrected
P1.05	AI2 displayed voltage 1	Range:0.500V~4.000V	Factory corrected
P1.06	AI2 measured voltage 2	Range:6.000V~9.999V	Factory corrected
P1.07	AI2 displayed voltage 2	Range:6.000V~9.999V	Factory corrected
P1.08	AI3 measured voltage 1	Range:0.500V~4.000V	Factory corrected
P1.09	AI3 displayed voltage 1	Range:0.500V~4.000V	Factory corrected
P1.10	AI3 measured voltage 2	Range:6.000V~9.999V	Factory corrected
P1.11	AI3 displayed voltage 2	Range:6.000V~9.999V	Factory corrected

These parameters are used to correct the AI to eliminate the impact of AI zero offset and gain.

They have been corrected upon delivery. When you resume the factory values, these parameters will be restored to the factory-corrected values. Generally, you need not perform correction in the applications.

Measured voltage indicates the actual output voltage value measured by instruments such as the multimeter. Displayed voltage indicates the voltage display value sampled by the inverter. For details, refer to H0.31, H0.32 and H0.33.

During correction, send two voltage values to each AI terminal, and save the measured values and displayed values to the function codes P1.00 to P1.11. Then the inverter will automatically perform AI zero offset and gain correction.

If the input voltage and the actual voltage sampled by the inverter are inconsistent, perform correction on site. Take AI1 as an example. The on-site correction is as follows:

- 1) Send a voltage signal (approximately 2 V) to AI1.
- 2) Measure the AI1 voltage and save it to P1.00.
- 3) View the displayed value of H0.31 and save the value to P1.01.
- 4) Send a voltage signal (approximately 8 V) to AI1.
- 5) Measure AI1 voltage and save it to P1.02.
- 6) View the displayed value of H0.31 and save the value to P1.03.

At correction of AI2 and AI3, the actually sampled voltage is respectively queried in H0.32 and H0.33.

For AI1 and AI2, 2 V and 8 V are suggested as the correction voltages. For AI3, -8 V and 8 V are suggested.

P1.12	AO1 target voltage 1	Range:0.500V~4.000V	Factory corrected
P1.13	AO1 measured voltage 1	Range:0.500V~4.000V	Factory corrected
P1.14	AO1 target voltage 2	Range:6.000V~9.999V	Factory corrected
P1.15	AO1 measured voltage 2	Range:6.000V~9.999V	Factory corrected
P1.16	AO2 target voltage 1	Range:0.500V~4.000V	Factory corrected
P1.17	AO2 measured voltage 1	Range:0.500V~4.000V	Factory corrected
P1.18	AO2 target voltage 2	Range:6.000V~9.999V	Factory corrected
P1.19	AO2 measured voltage 2	Range:6.000V~9.999V	Factory corrected

These parameters are used to correct the AO.

They have been corrected upon delivery. When you resume the factory values, these parameters will be restored to the factory-corrected values. You need not perform correction in the applications.

Target voltage indicates the theoretical output voltage of the inverter. Measured voltage indicates the actual output voltage value measured by instruments such as the multimeter.

P1.20	AI1 filtering dead zone	Range:0~255	Default:0
P1.21	AI2 filtering dead zone	Range:0~255	Default:0
P1.22	AI3 filtering dead zone	Range:0~255	Default:66

The group function is used to eliminate analog input jitter.the larger the set value, analog jitter smaller, but the larger the error.

## Group H0: Monitoring Parameters

You can view parameter values by using operation panel, convenient for on-site commissioning, or from the host computer by means of communication (address: 0x7000-0x7044).

H0.00	Running frequency (Hz)	0.01Hz
H0.01	Set frequency (Hz)	0.01Hz
H0.02	Output current (A)	0.01A
H0.03	Output voltage (V)	1V
H0.04	Output power (kW)	0.1kW
H0.05	Output torque (%)	0.1%
H0.06	Bus voltage (V)	0.1V

H0.07	X input state1	1
-------	----------------	---

It displays state of DI terminals. "1" indicates high level signal, and "0" indicates low level signal.

Bit4	Bit3	Bit2	Bit1	Bit0
X5	X4	X3	X2	X1

H0.08	Monitor the IO expansion card	1
-------	-------------------------------	---

It displays state of DI terminals. “1” indicates high level signal, and “0” indicates low level signal.

Bit4	Bit3	Bit2	Bit1	Bit0
X10	X9	X8	X7	X6

H0.09	DO output state	1
-------	-----------------	---

It displays state of DO terminals. “1” indicates high level signal, and “0” indicates low level signal.

Bit3	Bit2	Bit1	Bit0
R2	R1	Y2	Y1

H0.10	AI1 voltage (V)	0.01V
H0.11	AI2 voltage (V)	0.01V
H0.12	AI3 voltage (V)	0.01V

Whether AI1 and AI2 receives voltage input or current input is determined by setting of jumper J1 and J2 on the control board. The input current 1mA correspond to 0.5V.

H0.13	Input pulse frequency (kHz)	0.01kHz
-------	-----------------------------	---------

It displays DI5 high-speed pulse sampling frequency, in minimum unit of 10 Hz.

H0.14	PID setting	1
H0.15	PID feedback	1
H0.16	PID output	1

They display the PID setting value and PID feedback value.

PID setting = PID setting (percentage) \*FA-04

PID feedback = PID feedback (percentage) \* FA-04

PID output= PID output (percentage)\*FA.04

H0.17	Load speed	1
-------	------------	---

Displayed value reference to F8.12.

H0.18	Main frequency	0.01Hz
H0.19	Auxiliary frequency	0.01Hz

H0.18 displays the setting of main frequency.H0.19 displays the setting of auxiliary frequency.

H0.20	Feedback speed (unit:0.1Hz)	0.1Hz
-------	-----------------------------	-------

It displays the actual output frequency of the inverter.

H0.21	Count value	1
-------	-------------	---

It displays the current count value.Please refer to Fb.08 and Fb.09.

H0.22	Length value	1
-------	--------------	---

It displays the current length value.Please refer to Fb.05~Fb.07

H0.23	Linear speed	1m/Min
-------	--------------	--------

It displays the current linear speed.Please refer to Fb.06,Fb.07

H0.24	Accumulative power-on time	1Min
-------	----------------------------	------

It displays the current accumulative power-on time

H0.25	Accumulative running time	0.1Min
-------	---------------------------	--------

It displays the current accumulative running time

H0.26	Motor overload count	1
-------	----------------------	---

It displays the current overload degree

H0.27	Motor output current percentage	0.01%
-------	---------------------------------	-------

It displays the output current percentage (Relative to motor rated current)

H0.28	Remaining operating time	0.1Min
-------	--------------------------	--------

It displays the remaining operating time when it is timing running.



The description of timing running is refer to F4.42~F4.44.

H0.29	PLC stage	1
-------	-----------	---

It displays the current PLC stage

H0.30	Communication setting value	0.01%
-------	-----------------------------	-------

It displays the data written by means of the communication address 0x1000.

H0.31	AI1 input voltage (Before correction)	0.01V
-------	---------------------------------------	-------

H0.32	AI2 input voltage (Before correction)	0.01V
-------	---------------------------------------	-------

H0.33	AI3 input voltage (Before correction)	0.01V
-------	---------------------------------------	-------

It displays the AI1 input voltage, AI2 input voltage, AI3 input voltage before correction

The input current 1mA correspond to 0.5V.

## Chapter 8 Maintenance and Troubleshooting

### 8.1 Daily Maintenance and Inspection of AT550

#### 8.1.1 Daily Maintenance

Due to the effect of ambient temperature, humidity, dust and vibration, inverter's components age over time, leading to potential errors or shorter life of the motor drive. Therefore, it is necessary to perform maintenance on the inverter on daily basis. Below is the list of daily inspection:

- 1) if the inverter makes unusual sound while running;
- 2) if the motor vibrates while running;
- 3) if the installation environment have changes;
- 4) if the cooling fans are working properly;
- 5) if the inverter is overheated.

Daily Cleaning:

- 6) Keep the inverter clean;
- 7) Clean the dust on the surface of inverter, keeping them, especially the metal particles, from going inside inverter;
- 8) Clean the greasy dirt on the cooling fans.

#### 8.1.2 Periodic Inspection

Please inspect the places that is hard to spot. Below is the list of places that need to inspect periodically:

- 1) Inspect the vents and clean them regularly;
- 2) Check loose screws;
- 3) Check if the inverter corrodes;
- 4) Check if there are any arc marks on terminals
- 5) Main Circuit Insulation Test

**Note:** Disconnect the inverter and main circuit when measuring insulation resistance using a megohmmeter (DC 500V Megohmmeter). Do not test the control circuit insulation using an insulation resistance meter. No need to perform High Voltage Test since it has been done before leaving the factory

#### 8.1.3 Wear and Tear Parts Change

Inverter's wear and tear parts include cooling fans and electrolytic capacitor for filtering, and their life is closely related to ambient conditions and maintenance. Below are their life span:

Cooling Fans: 2-3 years

Electrolytic Capacitor: 4-5 years

**Note:** Standard life span is only valid under the conditions below. User may determine when to change parts according to their situation.

- Ambient Temperature: Annual average temperature is around 30°C.
- Duty Cycle: Less than 80%
- Operating Rate: Less than 20 hours per day

##### 1) Cooling Fans

Possible Damage Reasons: Worn bearings and aged fan blades

Criteria: if fan blades have cracks; if there is an unusual vibration sound at start-up

##### 2) Electrolytic Capacitor for Filtering

Possible Damage Reasons: Bad Input Power Supply, High Ambient Temperature, Frequent Load Jump, and Aged Electrolytes.

Criteria: If there is a leakage of liquid, If there is a bulge on safety valve, test of electrostatic capacitance, and test of insulation resistance.

#### 8.1.4 Storage for Inverter

A few notes that users need to know if they plan to store the inverter for a long or short period:

- 1) Put the product in the original package when storing it.

- 2) Long period of storage may result in the deterioration of electrolyte capacitance. Therefore, it is necessary to power it on in 2 years and have it stay on for at least 5 hours. Input voltage must slowly rise to the set value using a voltage regulator.

## 8.2 Warranty

- 1) Warranty may only apply to this inverter itself.
- 2) This Limited Warranty covers any defects in material or workmanship under normal use during the Warranty Period (please refer to the bar code on the product for the manufacture date) at no charge. After the Warranty Period, a reasonable charge will be applied.
- 3) During the Warranty Period, the following actions will result in a charge:
  - a) User does not follow the instruction manual and causes damage to the product;
  - b) Damage caused by fire, flood and abnormal voltage;
  - c) Damage caused by using the product improperly.
- 4) Any charge is subject to the company's standard. If an agreement is made, the agreement is prioritized.

## 8.3 Faults and Solutions

The AT550 provides a total of 24 pieces of fault information and protective functions. After a fault occurs, the inverter implements the protection function, and displays the fault code on the operation panel (if the operation panel is available).

Before contacting JACT for technical support, you can first determine the fault type, analyze the causes, and perform troubleshooting according to the following tables. If the fault cannot be rectified, contact the agent or JACT. Err22 is the inverter hardware overcurrent or overvoltage signal. In most situations, hardware overvoltage fault causes Err22.

Name	Display	Possible Causes	Solutions
Overcurrent During Acceleration	Err02	1: Inverter's output circuit is grounded or short; 2: Control mode is vector and no parameters identification; 3: Acceleration time is too short; 4: Voltage is too low; 5: Initiate start on the motor while it is still running; 6: Sudden load added while accelerating; 7: The model of inverter is too small; 8: The braking resistor is short.	1: Eliminate the peripheral failure; 2: Initiate the identification of motor parameters; 3: Increase acceleration time; 4: Adjust the voltage to the normal range; 5: Choose rotational speed tracking start or start it after the motor stops; 6: Cancel the sudden load addition; 7: Use the inverter that has a higher power level; 8: Check if the braking resistance is normal
Overcurrent During Deceleration	Err03	1: Inverter's output circuit is grounded or short; 2: Control mode is vector and no parameters identification; 3: Deceleration time is too short. 4: Voltage is too low; 5: Sudden load added while decelerating; 6: No braking units or braking resistors added 7: The braking resistor is short.	1: Eliminate the peripheral failure; 2: Initiate the identification of motor parameters; 3: Increase deceleration time; 4: Adjust the voltage to the normal range; 5: Choose rotational speed tracking start or start it after the motor stops; 6: Cancel the sudden load addition; 7: Check if the braking resistance is normal.

Overcurrent at Constant Speed	Err04	<p>1: Inverter’s output circuit is grounded or short;                  2: Control mode is vector and no parameters identification;                  3: Voltage is too low;                  4: Sudden load added during operation;                  5: The model of inverter is too small;                  6: The braking resistor is short.</p>	<p>1: Eliminate the peripheral failure;                  2: Initiate the identification of motor parameters;                  3: Adjust the voltage to the normal range;                  4: Choose rotational speed tracking start or start it after the motor stops;                  5: Cancel the sudden load addition;                  6: Use the inverter that has a higher power level;                  7: Check if the braking resistance is normal.</p>
Overvoltage During Acceleration	Err05	<p>1: Input voltage is too high;                  2: An external force drags the motor during acceleration;                  3: Acceleration time is too short;                  4: No braking units or braking resistors added</p>	<p>1: Adjust the voltage to the normal range;                  2: Remove the external force or add braking resistors;                  3: Increase acceleration time;                  4: Add braking units and braking resistors.</p>
Overvoltage During Deceleration	Err06	<p>1: Input voltage is too high;                  2: An external force drags the motor during deceleration;                  3: Deceleration time is too short;                  4: No braking units or braking resistors added</p>	<p>1: Adjust the voltage to the normal range;                  2: Remove the external force or add braking resistors;                  3: Increase deceleration time;                  4: Add braking units and braking resistors.</p>
Overvoltage at Constant Speed	Err07	<p>1: Input voltage is too high;                  2: An external force drags the motor during deceleration;</p>	<p>1: Adjust the voltage to the normal range;                  2: Remove the external force or add braking resistors;</p>
Power Supply Failure	Err08	<p>Input voltage is not within the range of regulation.</p>	<p>Adjust input voltage to the range of regulation.</p>
undervoltage	Err09	<p>1: Sudden power outages;                  2: Input voltage of the inverter is not within the range of regulation;                  3: Unusual bus voltage;                  4: Bridge rectifiers and snubber resistor malfunctions;                  5: Drive board malfunctions;                  6: Control board malfunctions.</p>	<p>1: Fault reset;                  2: Adjust the voltage to the normal range;                  3: Contact tech support;                  4: Contact tech support;                  5: Contact tech support;                  6: Contact tech support;</p>
Inverter Overload	Err10	<p>1: Excessive load or motor stalling;                  2: The model of inverter is too small.</p>	<p>1: Reduce load and inspect the motor and mechanical conditions;                  2: Use the inverter that has a higher power level.</p>

Motor Overload	Err11	<ol style="list-style-type: none"> <li>1: Check if F9.01: motor protection parameter is appropriately set;</li> <li>2: Excessive load or motor stalling;</li> <li>3: The model of inverter is too small.</li> </ol>	<ol style="list-style-type: none"> <li>1: Set the parameter correctly;</li> <li>2: Reduce load and inspect the motor and mechanical conditions;</li> <li>3: Use the inverter that has a higher power level.</li> </ol>
Input Phase Loss	Err12	<ol style="list-style-type: none"> <li>1: Abnormal three-phase input power;</li> <li>2: Drive board malfunctions;</li> <li>3: Lightning protection board malfunctions;</li> <li>4: Main control board malfunctions</li> </ol>	<ol style="list-style-type: none"> <li>1: Check and eliminate the problems in the peripheral circuit;</li> <li>2: Contact tech support;</li> <li>3: Contact tech support;</li> <li>4: Contact tech support.</li> </ol>
Output Phase Loss	Err13	<ol style="list-style-type: none"> <li>1: Abnormal wiring from inverter to motor;</li> <li>2: Unbalanced three-phase output of inverter when motor operates;</li> <li>3: Drive board malfunctions;</li> <li>4: Modules malfunction.</li> </ol>	<ol style="list-style-type: none"> <li>1: Eliminate peripheral errors;</li> <li>2: Inspect three-phase winding and eliminate errors;</li> <li>3: Contact tech support;</li> <li>4: Contact tech support.</li> </ol>
Modules Overheat	Err14	<ol style="list-style-type: none"> <li>1: Ambient temperature is too high;</li> <li>2: Clogged vents;</li> <li>3: Broken fans;</li> <li>4: Broken thermistor modules;</li> <li>5: Broken inverter module;</li> </ol>	<ol style="list-style-type: none"> <li>1: Lower ambient temperature;</li> <li>2: Clean the vents;</li> <li>3: Replace the fans;</li> <li>4: Replace the thermistor modules;</li> <li>5: Replace the inverter modules.</li> </ol>
External Equipment Fault	Err15	<ol style="list-style-type: none"> <li>1: External fault signal input via Terminal X.</li> <li>2: External fault signal input via virtual I/O.</li> </ol>	Reset the operation.
Communication Failure	Err16	<ol style="list-style-type: none"> <li>1: Host computer malfunctions;</li> <li>2: Communication wires malfunction;</li> <li>3: Incorrect setting of FD group of communication parameters.</li> </ol>	<ol style="list-style-type: none"> <li>1: Check the wiring of host computer;</li> <li>2: Check the wiring of communication;</li> <li>3: Correctly set the communication parameters.</li> </ol>
Contactors Failure	Err17	<ol style="list-style-type: none"> <li>1: Drive board and power malfunction;</li> <li>2: Contactors malfunction.</li> </ol>	<ol style="list-style-type: none"> <li>1: Change the drive board or power board;</li> <li>2: Change the contactors.</li> </ol>
Current Detection Failure	Err18	<ol style="list-style-type: none"> <li>1: Check hall devices;</li> <li>2: Check drive board.</li> </ol>	<ol style="list-style-type: none"> <li>1: Replace the hall devices;</li> <li>2: Replace the drive board.</li> </ol>
Motor Auto-tuning Fault	Err19	<ol style="list-style-type: none"> <li>1: The motor parameters are not properly set according to the nameplate.</li> <li>2: The motor auto-tuning times out</li> </ol>	<ol style="list-style-type: none"> <li>1: Set the motor parameters according to the nameplate properly.</li> <li>2: Check the cable connection between the inverter and the motor.</li> </ol>

Encoder Fault	Err20	1: The encoder model does not match. 2: The cable connection of the encoder is incorrect. 3: The encoder is damaged. 4: The PG card is faulty	1: Set the encoder type correctly based on the actual situation. 2: Eliminate external faults. 3: Replace the damaged encoder. 4: Replace the faulty PG card.
EEPROM Read and Write Failure	Err21	Damaged EEPROM Chip	Replace the main control board.
Inverter Hardware Malfunctions	Err22	1: Overvoltage; 2: Overcurrent.	1: Deal it as overvoltage error; 2: Deal it as overcurrent error.
Ground Fault Errors	Err23	Ground fault of the motor	Change electric cables or motors.
User-Defined Fault 1	Err27	The user-defined fault 1 signal is input via Terminal X.	Reset the operation
User-Defined Fault 2	Err28	The user-defined fault 2 signal is input via Terminal X.	Reset the operation
Reach the set total Power-On Time	Err29	Accumulated power-on time (F8.13) reaches the set value (F4.16).	Clear the records using the initiation of parameters.
Offload Errors	Err30	Operation current of inverter is smaller than F9.64.	Confirm the removal of load or if parameters setting of F9.64 and F9.65 matches real situation.
PID Feedback Lost During Operating	Err31	The PID feedback is lower than the setting of FA.26.	Check the PID feedback signal or set FA.26 to a proper value.
CBC Errors	Err40	1: Excessive load or motor stalling; 2: The model of inverter is too small.	1: Reduce load and inspect the motor and mechanical conditions; 2: Use the inverter that has a higher power level.
Large Speed Deviation	Err42	1: The encoder parameters are set incorrectly. 2: The motor auto-tuning is not activated. 3: F9.69 and F9.70 are set incorrectly.	1: Set the encoder parameters properly. 2: Perform the motor auto-tuning. 3: Set F9.69 and F9.70 correctly based on the actual situation.
Motor over-speed	Err43	1: The encoder parameters are set incorrectly. 2: The motor auto-tuning is not activated. 3: F9.67 and F9.68 are set incorrectly	1: Set the encoder parameters properly. 2: Perform the motor auto tuning. 3: Set F9.67 and F9.68 correctly based on the actual situation.

### 8.4 Common Errors and Solutions

SN	Error Types	Possible Causes	Solutions
1	No Display With Power On	No power grid voltage or voltage is too low; Broken power switch on the drive board; Broken bridge rectifiers; Broken snubber resistors of motor drive; Broken control board and keypad; Control board is disconnected to drive board and keypad.	Inspect input power; Check bus voltage; Unplug and plug the wires on pin 8 and pin 28; Contact tech support.
2	Garbled Codes On the Display	Bad connection between drive board and control board; Damaged parts on control board; Short motor or motor cables ground fault; Hall errors; Power grid voltage too low;	Unplug and plug the wires on pin 8 and pin 28; Contact tech support.
3	Err23” Alert on the Display	Short motor or motor cables ground fault; Broken motor drive;	Measure the insulation of the motor and the output cable using a megohmmeter; Contact tech support.
4	Frequent “Err14” Module Overheated Alert	The setting of carrier frequency is too high; Broken fans or clogged vents; Internal damaged parts of motor drive (Thermocouple, etc.);	Lower the carrier frequency ( F0.15); Replace fans, and clean the vents; Contact tech support.
5	Motor Does Not Work After Starting The Motor Drive	Motor and motor cables; Incorrect motor drive parameters setting (Motor parameters); Bad connection between drive board and control board; Drive board malfunctions.	Check the connection between motor drive and motor; Change the motor or eliminate mechanic errors; Check and reset the motor parameters.
6	X Terminal Failure	Parameter setting errors; External signal errors; PLC and loose +24V jump wire; Control board errors.	Check and reset group F2 parameters; Reconnect external signal wires; Reconfirm PLC and +24V jump wire; Contact tech support.
7	The motor speed cannot be increased in CLVC mode	The encoder is faulty. The encoder cable is connected incorrectly or in poor contact. The PG card is faulty. The drive board is faulty.	Replace the encoder and ensure the cabling is proper. Replace the PG card. Contact the agent or JACT for technical support.
8	Frequent Error Reports of Overcurrent and Overvoltage By Motor Drive	Incorrect motor parameters setting; Inappropriate Acceleration /Deceleration Time; Load Fluctuation.	Reset motor parameters or tune the motor; Set a proper acceleration /deceleration time; Contact tech support

9	Err17 Alert	Soft-starter does not pull in;	Check if there are the loose wires on the contactor; Check if the contactor malfunctions; Check if 24V power supply can normally power the contactor; Contact tech support.
10	Display “8.8.8.8.”	Damaged parts on the control board;	Change the control board.



# Appendix A: MODBUS Communication Protocol

AT550 series inverters provides RS485 communication port and supports the Modbus-RTU slave communication protocol. Central control may be realized via computers or PLC. Through this communication protocol, it is possible to change the settings of inverter’s operation commands, to modify or read function parameters, and to read inverter’s operation status and error information, etc.

## 1.1 Protocol Contents

This serial communication protocol defines the contents and use format that transmits in the serial communication, which includes polling (or broadcasting) format; for encoding methods of host, it includes the functions requiring actions, transmitting data and error calibration, etc. For the response of slave, it has the same structure, including actions confirmed, returning data, and error calibration, etc. If error occurs while slave is receiving information or it can not complete the actions host requires, it will return an error information to host as feedback.

### 1.1.1 Application

A PC/PLC control network that has “single host and multiple slaves” of RS485 bus is connected to inverter as a communication slave.

### 1.1.2 Bus Structure

#### 1). Hardware Connection

RS485 needs connected to inverter.

#### 2). Topology Structure

A system of single host and multiple slaves. Each communication device has only one slave address in the network, and one device as the communication host (PC Host , PLC and HMI, etc) spontaneously initiate the communication to read or write the parameters on slaves. Other devices as the communication slaves respond to the access from the host or communication operations. Only one device can send out data at one time, and other devices are receiving data.

The setting range of slave address is 1~247 of which 0 is the broadcasting communication address. The slave address in the network has to be unique.

#### 3). Communication Transmission Methods

Asynchronous serial communication and two-way alternating communication. While transmitting data through asynchronous serial communication, the data is sent out as messages, one frame at a time. According to MODBUS-RTU protocol, when the free time of no data on communication cables is larger than the transmission time of 3.5 Byte, it indicates a new beginning of a communication frame.

AT550 series inverter’s built-in communication protocol is Modbus-RTU slave communication protocol, responding to host’s “reading/commands” or doing the corresponding actions according to host’s “reading/commands” then responding with communication data.

Hosts can be referred to personal computer (PC), industrial control device or programmable logic controller (PLC),etc. The hosts can either communicate with one slave alone or send out some broadcasting information to all the slaves. For the individual "query/command" of the host, the accessed slave must return a response frame. For the broadcasting information the host sends out, the slaves do not have to return a feedback.

## 1.2 Communication Frame Description

### 1.2.1 Communication Frame Format

AT550 series inverter’s Modbus communication data format is RTU mode as below:

A byte contains: initial bit, 8 bits of data, check bit and stop bit.

Initial Bit	Bit1	Bit2	Bit3	Bit4	Bit5	Bit6	Bit7	Bit8	Check Bit	Stop Bit
-------------	------	------	------	------	------	------	------	------	-----------	----------

In the RTU mode, messages have to sent out in between of the pause intervals of at least 3.5 characters time, which can be easily realized given the various character time in the network baud rates.

The first domain transmitted is device address where hexadecimal is used during the transmission. Network devices continuously monitor the network bus, including pause intervals. When the first domain (address domain) receives messages, each device will decode them to decide if the messages are sent to them. After the last transmitted character, an pause of at least 3.5 characters time indicates the end of a message. A new message may start after the pause. If a new message is sent out before the pause of 3.5 characters time ends, the receiving device will consider it as a continuation of the previous message. Such action will lead to an error because the last value of CRC domain is incorrect.

RTU Data Frame Format as below:

Frame Head	Slave Address	Command Codes	Function Codes	Data	Check	End
------------	---------------	---------------	----------------	------	-------	-----

Data Frame Bits Descriptions:

Frame Head START	Larger than the transmission time of 3.5 characters
Slave Address ADR	Communication Addresses Range: 1~247; 0=Broadcast Address
Command Codes CMD	03: Read Slave Parameters; 06: Write Slave Parameters
Function Codes Address H	Inverter's built-in parameter address which is represented by hexadecimal is divided into function code parameters and non-function code parameters. Please refer to address definitions for more info. While transmitting, high bit is in front of low bit.
Function Codes Address L	
Function Codes Count H	This frame reads the number of function codes. If it's 1, it means 1 function code is detected. High bit is in front of low bit while transmitting. This protocol can only rewrite 1 function code.
Function Codes Count L	
Data H	Response data or data to write in. High bit is in front of low bit while transmitting.
Data L	
CRC CHK Low Bit	Detection Value: CRC16 Check Value. Low bit is in front of high bit while transmitting Refer to CRC Check Description for calculation methods.
CRC CHK High Bit	
END	3.5 Characters

### 1.1.2 Command Codes and Communication Data Description

Inverter supports read and write of word parameters. Operation Command for Read: 0x03; Operation Command for Write:0x06. Byte or bit read/write operations are not supported.

1) Command Code: 03H, read N words (Up to 12 words).

For example: An inverter's slave address is 01 and its start address is F003. Read 1 word from the start address, and this frame's structure is described as the following:

Host Command Information:

ADR	01H
CMD	03H
Start Address High Bit	F0H
Start Address Low Bit	03H
Register Count High Bit	00H
Register Count Low Bit	01H
CRC CHK Low Bit	CRC CHK's value to be calculated
CRC CHK High Bit	

Slave's Response Message:

When Fd.05 is 0 (Non-Standard Modbus Protocol):

ADR	01H
CMD	03H
Byte Count High Bit	00H
Byte Count Low Bit	02H
F003H High Bit	00H
F003H Low Bit	04H
CRC CHK Low Bit	E5
CRC CHK High Bit	C9

When Fd.05 is 1 (Standard Modbus Protocol):

ADR	01H
CMD	03H
Byte Count Low Bit	02H
F003H High Bit	00H
F003H Low Bit	04H
CRC CHK Low Bit	B9
CRC CHK High Bit	87

2) Command Code 06H. Write 1 word.

Function: Write the data of a word to the designated data address in order to modify the parameters of inverter.

For example: Write 5000(1388H) to the address F00A ([F0.10]) of Inverter (Slave address: 01H). This frame is described as the following:

Host Command Information:

ADR	01H
CMD	06H
Data Address High Bit	F0H
Data Address Low Bit	0AH
Data Content High Bit	13H
Data Content Low Bit	88H
CRC CHK Low Bit	CRC CHK's value to be calculated
CRC CHK High Bit	

Slave Response Information:

ADR	01H
CMD	06H
Data Address High Bit	F0H
Data Address Low Bit	0AH
Data Content High Bit	13H
Data Content Low Bit	88H
CRC CHK Low Bit	97
CRC CHK High Bit	9E

### 1.2.3 CRC Check Methods

CRC(Cyclical Redundancy Check) utilizes RTU frame format, and its messages include the error check domain based on CRC method. CRC domain is able to detect the content of messages. CRC domain has two bytes, including 16 bits of binary value. It is added to the messages after CRC is calculated by transmission device. Receiving device will recalculate CRC in the messages and compare it with the value received in CRC domain. If they are not equal, it indicates an error occurs during the transmission.

## 1.3 Communication Data Address Definition

Function Code Parameters Read/Write (Some function codes are non-modifiable and subject to the manufacturers or for the purpose of monitoring.

### 1.3.1 Labeling Rules of Function Code Parameters Address

Register address is divided into higher bytes and lower bytes depending on the inverter's function codes sequence. Higher bytes represents the group sequence of function parameters, and lower bytes represents the sequence of function parameters inside a group. Both of them need converted into hexadecimal.

Higher Bytes: F0~FF(Group F)、70 (Group H)

Lower Bytes: 00~FF

Function codes group number and their communication access addresses:

Communication Access Address for F0-FE: 0xF000~0xFEFF; Communication Access Address for H0: 0x7000~0x70FF.

For example, if the function code is F3.12, then its access address is 0xF30C.

Note: Group FF: No reading or modification of parameters.

Group H: Parameters can be read only. No modification of parameters.

Some parameters is not modifiable during the operation of inverter; Some can not be modified under any circumstances; Please note the range and units of parameters and their description when modifying them.

In addition, frequent use of EEPROM will reduce the life span of it. Therefore, you may change the values of some function codes in RAM instead of saving them at EEPROM. It is possible to do so by changing the high bit F of the function code's address to 0. For example, if the function code F3-12 is not to be saved at EEPROM, the address can be written as 030C.

### 1.3.2 Address Description of Other Function Parameters

#### 1). Halt/Operating

Parameter Address	Parameter Description	Parameter Address	Parameter Description
1000H	*Communication Setting Value (Decimal) -10000~10000	1010H	PID Setting
1001H	Operating Frequency	1011H	PID Feedback
1002H	Bus Voltage	1012H	PLC Procedures
1003H	Output Voltage	1013H	PULSE Input Pulse Frequency, Unit: 0.01kHz
1004H	Output Current	1014H	Feedback Speed, Unit: 0.1Hz
1005H	Output Power	1015H	Remaining Operating Time
1006H	Output Torque	1016H	AI1 Voltage Before Calibration
1007H	Operating Speed	1017H	AI2 Voltage Before Calibration
1008H	DI Input Sign	1018H	AI3 Voltage Before Calibration
1009H	DO Output Sign	1019H	Linear Speed
100AH	AI1 Voltage	101AH	Current Power-On Voltage
100BH	AI2 Voltage	101BH	Current Operating Time

100CH	AI3 Voltage	101CH	Input Pulse Frequency, Unit: 1Hz
100DH	Count Input	101DH	Communication Setting Value
100EH	Length Input	101EH	Actual Feedback Speed
100FH	Load Speed	101FH	Main Frequency X Display
-	-	1020H	Auxiliary Frequency Y Display

Note:

Communication setting value is a relative value of 100 percentage. 10000 corresponds to 100.00% while -10000 to -100.00%.

For the frequency dimension, this percentage is relative to the percentage of the max frequency (F0.10).

2). Inverter Receiving Control Commands: (Write Only)

Command Address	Command Function
2000H	0001: Forward Operation
	0002: Reverse Operation
	0003: Forward JOG
	0004: Reverse JOG
	0005: Coasting to Stop
	0006: Decelerating to Stop
	0007: Fault Reset

3). Reading Inverter’s Status: (Read Only)

Status Address	Status Function
3000H	0001: Forward Operation
	0002: Reverse Operation
	0003: Halt

4)Digital Output Terminals Control: (Write Only)

Command Address	Command Contents
2001H	BIT0: Y1 Output Control BIT1: Y2 Output Control BIT2: RELAY1 Output Control BIT3: RELAY2 Output Control BIT4: FMR Output Control

5) Analog Output AO1 Control: (Write Only)

Command Address	Command Contents
2002H	0~7FFF represents 0%~100%

6). Analog Output AO2 Control: (Write Only)

Command Address	Command Contents
2003H	0~7FFF represents 0%~100%

7) Pulse Output Control: (Write Only)

Command Address	Command Contents
2004H	0~7FFF represents 0%~100%

8) Faults Description of Inverter

Faults Address	Faults Information	
8000H	0000: No Error 0001: Reserved 0002: Over current during Acceleration 0003: Over current during Deceleration 0004: Over current at a Constant Speed 0005: Over voltage during Acceleration 0006: Over voltage during Deceleration 0007: Over voltage at a Constant Speed 0008: Buffer Resistor Overload 0009: Under voltage 000A: Inverter Overload 000B: Motor Overload 000C: Power Input Phase Loss 000D: Power Output Phase Loss 000E: Module Overheated 000F: External Parts Error 0010: Communication Errors 0011: Contactor Fault 0012: Current Detection Errors 0013: Motor Auto-tuning Errors 0014: Encoder/PG Card Errors	0015: EEPROM Read-Write Error 0016: Inverter Hardware Errors 0017: Motor Short to Ground 0018: Reserved 0019: Reserved 001A: Operating Time Reached 001B: User-Defined Fault 1 001C: User-Defined Fault 2 001D: Accumulated Power-On Time Reached 001E: Load Drop 001F: PID Feedback Lost during Operating 0028: Rapid Current Limit Over-Time Fault 002A: Large Speed Deviation 002B: Motor Over-speed 005A: Encoders PPR Setting Fault 005B: Encoder Disconnected 005C: Faulty Initial Position

Communication Error Address	Error Descriptions
8001	0000: No Error 0001: Incorrect Password 0002: Incorrect Command Codes 0003: CRC Check Error 0004: Invalid Address 0005: Invalid Parameters 0006: Invalid Parameters Modification 0007: System is locked 0008: EEPROM is in operation

1.4 Description of Group FD Communication Parameters

	Baud Rate	Factory Value	5
Fd.00	Range of Settings	0: 300BPS 1: 600BPS 2: 1200BPS 3: 2400BPS 4: 4800BPS 5: 9600BPS 6: 19200BPS 7: 38400BPS 8: 57600BPS 9: 115200BPS	

This parameter is used to set the data transmission rate between host and inverter. Note: The baud rates of host and inverter have to be equal in order to communicate properly. The larger the baud rate is, the faster the communication is.

Fd.01	Data Format	Factory Value	0
	Range of Settings	0: No Check: Data Format <8,N,2> 1: Even Parity Check: Data Format <8,E,1> 2: Odd Parity Check: Data Format <8,O,1> 3: No Check: Data Format <8-N-1>	

The data format of host has to match that of inverter. Otherwise, the communication will fail.

Fd.02	Address	Factory Value	1
	Range of Settings	1~247, 0 is the broadcasting address	

When the address of this inverter is set to 0, it is the broadcasting address and able to broadcast by the host.

The address of this inverter is unique (except the broadcasting address), which is the foundation of point-to-point communication between the host and inverter.

Fd.03	Response Delay	Factory Value	2ms
	Range of Settings	0~20ms	

Response Delay: It indicates the time interval between the end of inverter receiving data and sending it to the host. If the response delay is less than the time of system processing, then the delay is consistent with the time of system processing; if the response delay is larger than the time of system processing, then it will have to wait until the response time is reached and sends data to the host.

Fd.04	Communication Over-time	Factory Value	0.0s
	Range of Settings	0.0s (invalid); 0.1s~60.0s	

When the function code is set to 0.0s, the parameter becomes invalid.

When this function code is set as valid, if the time interval between this communication and next communication is larger than the communication over-time, it will report communication error (Err16). Usually it is set as invalid. This parameter can also be set to monitoring the status of communication in a system of continuous communication

Fd.05	Communication Protocol Selection	Factory Value	0
	Range of Settings	0: Non-standard Modbus Protocol; 1: Standard Modbus Protocol	

Fd.05=1: Select standard Modbus protocol.

Fd.05=0: Select non-standard Modbus protocol. When reading commands, the number of the bytes received from the slave is one byte longer than the standard Modbus protocol

Fd.06	Communication Reading Current Resolution	Factory Value	0
	Range of Settings	0: 0.01A 1: 0.1A	

It determines the output unit of current value when communication reading the current.